



Mechanical seals in  
mixing and separating processes  
in the chemical industry.

*Processes, application examples,  
seal designs  
and supply systems.*



# Seal selection

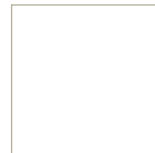

Seal selection for top entry arrangements. Agitators for steel, stainless steel and glass-lined vessels Connection sizes according to DIN				
Medium toxic or dangerous for the environment			Medium non-toxic, not dangerous for the environment	
Double seal, pressurized with constant barrier pressure, no process leakage to the atmosphere			Single seal, process leakage to the atmosphere is permitted or directed to the drain	Single seal or double seal, unpressurized quench, process leakage into the buffer liquid is permitted or directed to the drain
Dry running, pressure up to 6 bar, barrier medium gas (N <sub>2</sub> )	Lubricated, pressure up to 6 bar (16 bar), barrier medium liquid	Contactless, pressure up to 6 bar, barrier medium gas (N <sub>2</sub> )	Dry running, pressure up to 6 bar, no barrier medium	Lubricated, pressure up to 6 bar, quench medium liquid
SeccoMix® 481...D.. SeccoMix® 461...D..	M481K...D.. M461K...D..	AGSZ 481K..D.. AGSZ 461K...D..	SeccoMix® 481 SeccoMix® 461	M481K.. or M481K...D M461K.. or M461K...D..
Seal supply system				
Gas supply GSS4016/A ...	Closed circuit TS system, open circuit SPA, SPN	Gas supply GSS4016/A ...	No supply system necessary	Quench system

Seal selection for top, side or bottom entry arrangements. Agitators, dryers, mixers, filters and special equipment. Connection sizes according to EagleBurgmann standards or as required					
Sterile equipment		No sterile equipment			
Double seal, pressurized with constant barrier pressure or with pressure adjustment		Double seal or multiple seal, pressurized with constant barrier pressure or with pressure adjustment			
Pressure up to 6 bar, barrier medium gas (N <sub>2</sub> )	Pressure up to 16 bar, barrier medium liquid	Pressure up to 6 bar, barrier medium gas (N <sub>2</sub> )	Pressure up to 16 bar, barrier medium liquid	Pressure up to 25 bar, barrier medium liquid	Pressure up to 250 bar, barrier medium liquid
AGSR3-D AGSR3L-D series	MR333-D MR333L-D series	AGSR5-D AGSR5L-D series	MR5-D MR5L-D series	HS-D, HSL-D series	HSH-D, HSHL-D, HSH(V)-D, HSH(V)L-D, bottom entry HSHLU-D series
Seal supply system					
Gas supply GSS4016/A	Closed circuit TS system, sterile	Gas supply GSS4016/A ...	Closed circuit TS system DRU pressure booster	Open circuit SPA SPN	Open circuit SPA SPN

# Content

Seal selection	2
Seals for mixing and separating processes	4
Mixing processes	6
Separating processes	7
Mechanical seals in mixing processes	8
Mechanical seals in mechanical and thermal separation processes	12
EagleBurgmann agitator seals – the complete range	16
EagleBurgmann seal supply systems	20



**M461L-D for glass-lined tanks**



**HSMR in a vacuum dryer**

# Seals for mixing and separating processes

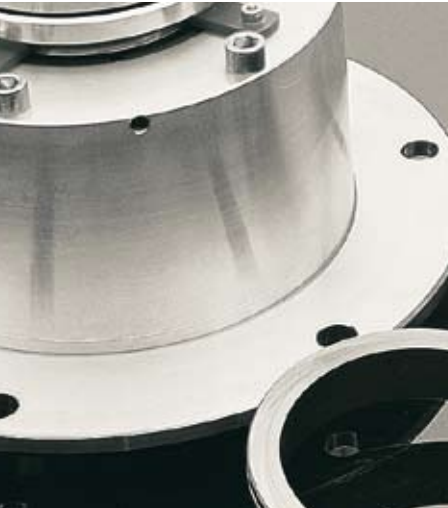
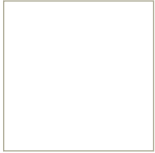

The manufacturing of chemical and pharmaceutical products puts considerable strain on the sealing technology. In addition to the process specific properties, the sealing systems must meet ever increasing requirements in terms of service life and reliability in a constantly growing global market.

Optimum quality, a worldwide service network and decades of experience of application engineering have made EagleBurgmann the leading manufacturer of sealing systems in the chemical and pharmaceutical industry, biotechnology, food industry, agrochemical industry, dispersion and micro-wet milling technology, flue gas desulphurisation and many other processes. We have developed sealing solutions jointly with our customers and engineers, with due regard to the characteristics of the processes and equipment used. Today, reliable production would not be feasible without these sealing solutions.

The range of application of EagleBurgmann agitator seals is wide:  
 Shaft diameter: 20 ... 500 mm  
 (0.787 ... 19.685")  
 Temperature: -80 ... +350 °C  
 (-112 ... 662 °F)  
 Pressure: Vacuum ... 250 bar  
 (3,625 PSI)  
 Sliding velocity: ... 20 m/s (65 ft/s)

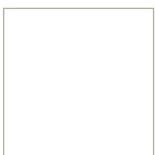

EagleBurgmann can provide technical solutions for **aggressive, corrosive, adhesive, viscous, toxic, explosive, dry, environmentally hazardous or valuable media**. Both modular systems and process-optimised engineered solutions are used. By combining these with mature and reliable seal supply systems, EagleBurgmann is able to offer the complete range of services through to TotalSealCare™ – a modular service from a single supplier.

Beyond this in the pharmaceutical industry, EagleBurgmann seals fulfil special requirements and directives, e.g.

- SIP Sterilisation in Place
- CIP Cleaning in Place
- cGMP current Good Manufacturing Practice
- EHEDG Design of Mechanical Seals for Hygienic and Aseptic Applications
- FDA Food and Drug Administration
- QHD Qualified Hygienic Design

EagleBurgmann dual mechanical seals meet the requirements of the **German Clean Air Directive** (TA-Luft).

An **Atex declaration of conformity** can be issued for every EagleBurgmann mechanical seal provided that the technical design and the arrangement meet the required operating conditions and the following precise operating conditions of use are known:

- Area of use (zone, device group)
- Required temperature class
- Medium (medium class)
- Maximum pressure at the mechanical seal
- Maximum temperature of the process medium at the mechanical seal
- Rotational speed
- Seal type, combination of face materials and size
- Buffer/barrier medium

This brochure sets out a range of solutions for different processes, machines and equipment. The selection matrix on page 2 will help you to identify the right seal for many different applications.



**Batch operations in process engineering**

For the sake of simplicity, many processes in the chemical, pharmaceutical or biotech industries can be broken down into two main areas from the viewpoint of the sealing technology:

**Mixing processes**

Agitating, mixing and kneading are basic unit operations for combining of materials. The aim is to balance out differences in concentration and to achieve greater homogeneity.

**Mechanical and thermal separation processes**

Centrifugation, filtering, drying and evaporating are examples of unit operations for separating processes. The aim may be to obtain a high purity end product or to separate out by-products.

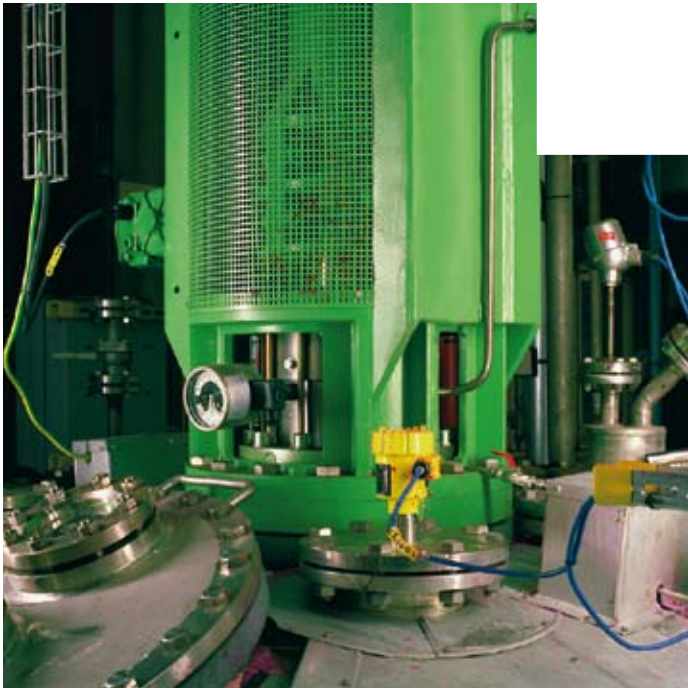
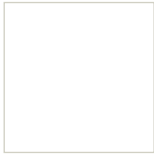
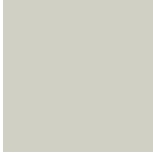
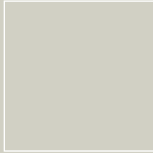

**Top entry agitator with AGS481.  
Applied in sun protection products  
at BASF Ludwigshafen.**



# Mixing processes



Mixing processes are particularly important in the chemical industry. For a start, intermediate or end products are often mixtures, dispersions or emulsions, for example. And, for a chemical reaction, the reactants must be distributed as homogeneously as possible to guarantee an optimum heat and mass transfer. We distinguish between homogeneous and heterogeneous mixtures. Homogeneous mixtures consist of just one phase, e.g. salt solutions, alloys or air. Heterogeneous mixtures comprise several phases, such as emulsions or suspensions. As a rule, we use agitating for liquid phases, kneading for high-viscosity, paste-like media and mixing for solid substances.

An agitator is generally used for mixing and agitating operations involving mixtures of substances consisting primarily of the liquid phase. The requirement for a successful sealing solution is a clear definition of the operating conditions.

The tasks of the mixing technology can be described as follows:

## Homogenisation

creates a uniform phase of several liquids that are soluble in one another for the purposes of balancing out differences in concentration and temperature.

## Intensification

increases the heat exchange between the liquid phase and the heat transfer surface

## Suspending

is the even distribution of solids in liquids. In the starting phase, the solids at the bottom are whirled up. In the end phase, the solids are evenly distributed in the tank.

## Dispersing

Comminuting a substance or breaking a gas down and distributing it in a liquid. The aim of dispersing is to increase the surface area between the disperse phase and the continuous phase in order to improve the mass transfer between them which increases in proportion with the size of the surface. Dispersing is also used to stabilise emulsions.

A special technology has been developed for dispersing and micro wet milling. The application requirements extend from low to high viscosity products that have to be dispersed down to nanometer range. For these applications, agitated media mills are used to disperse powdered substances in liquid phases as finely as possible.

This requires particularly robust seal designs to guarantee successful operation. EagleBurgmann can supply suitable seal systems for all such mixing and agitating applications.



Polymers production at BASF Ludwigshafen. Stainless steel tank with top entry agitator.

Medium: Preproduct for polymers production  
Temperature  $t_1$ : 120 °C  
Pressure  $p_1$ : 4 bar  
Rotational speed: 147 min<sup>-1</sup>  
Seal: M451KL-D21/80-E2  
with resublimation barrier with permanent flow of deionised water  
Supply system: TS1016/A007  
Barrier medium : Glycol / water  
Barrier pressure  $p_3$ : 6 bar

# Mechanical and thermal separation processes



The separation of mixtures of substances is one of the most important unit operation in processes. It normally represents more than half of the investment in a chemical production plant. The majority of the raw materials and the products obtained by chemical reactions are mixtures of substances that have to be separated into the different components for further processing or end use. We distinguish between mechanical and thermal separation processes according to which physical properties are used for separation. Mechanical separation methods include e. g. centrifugation and filtering where different densities of the various components are used. Thermal separation methods such as drying and evaporating utilise the different boiling points for separation.

The following separation processes are of particular importance in sealing technology.

## Centrifugation

Separators and decanters separate solids from liquids or liquid mixtures and remove the solids at the same time. Centrifuges as stand-alone machines or integrated into complete process lines are used to implement new process technologies and make the production efficient and cost-effective. The options for using mechanical separation tech-

nologies have significantly increased over the past few years. Separators and decanters are used in the chemical, pharmaceutical and biotech industries, oil and fat recovery and starch industry and in industrial biotechnology.

## Filtering

Filtering is the mechanical separation of a suspension into the liquid and solid phases using a filter medium. Filters perform a large number of solid/liquid separating applications. For example, modules of different designs are used in closed systems for optimised solutions that are matched to the specific application.

## Drying

By drying, we mean the removal or reduction of the liquid content in a solid by thermal treatment. The liquid is converted into the vapour phase and removed. Drying involves a very high power consumption and must be carried out gently to prevent product deterioration, so it requires particular attention. Thermal drying always stresses the solid. It is therefore important to ensure that the process is safe as well as maintains the product quality.

We distinguish between convection, contact and radiant drying according to the heat transfer method.

It is also possible to distinguish by the operating conditions. For example, with

air drying, the drying is carried out with hot air at atmospheric pressure. For vacuum drying a vacuum is used. This causes the boiling point and thus the drying temperature to drop considerably, which makes the process gentler on the product.

## Evaporation

Evaporation uses the addition of heat to evaporate and remove the solvent from a solution. This method is used to concentrate a solution, for example, to recover the pure solvent or to precipitate the dissolved solid by crystallisation.



Gas-lubricated  
AGSRL-D

# Mechanical seals in mixing processes

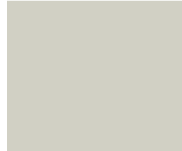
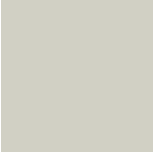
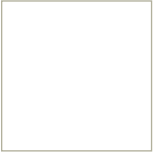

In closed agitator or vessels, the rotating agitator shaft must be sealed off from the cover or bottom of the vessel. This type of arrangement is known as a top or bottom entry installation. There are also horizontally arranged shaft entries and side arrangements that are not horizontal.



This creates very different requirements for the mechanical seals. To meet users' expectations of longer service life for low investment costs, EagleBurgmann has developed families of seals that fully cover a wide range of applications and are based on many years of experience and development.

These seal designs are standardised and thus provided the most cost-effective solution for the required

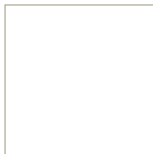

**Production of dispersions at BASF Ludwigshafen. Stainless steel vessel with top entry agitator.**

**Medium: dispersions**  
**Temperature  $t_1$ : 50 °C**  
**Pressure  $p_1$ : 0 ... 3 bar**  
**Rotational speed: 0 ... 30 min<sup>-1</sup>**  
**Seal: M451KL-D20/200-E1**  
**Supply system: SPA 2020/A40-V1**  
**Barrier medium : Glycol**  
**Barrier pressure  $p_2$ : 5 bar**



application, but are still extremely reliable. Engineered solutions are still needed for special equipment. The seal design depends on the type of installation and the process-specific load. The mechanical, process-specific, physical, chemical and safety requirements must all be taken into account in the design of the mechanical seal.

Seals may also have additional design features depending on the process requirements. These may include a

## Cooling flange

for additional cooling of the seal for process temperatures in excess of 200 °C.

## Leakage drain

Leakages of media that could harm the product or environment can be drained off into an external system.

## Polymerisation barrier

prevents polymerisation of the product in the dynamic seal area by means of a liquid reservoir on the process side or by flushing.

## Resublimation barrier

prevents deposits in the dynamic seal area released by product resublimation by means of a liquid reservoir on the process side or by flushing.

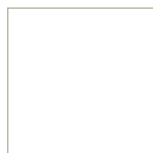



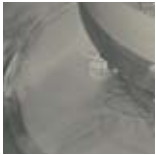
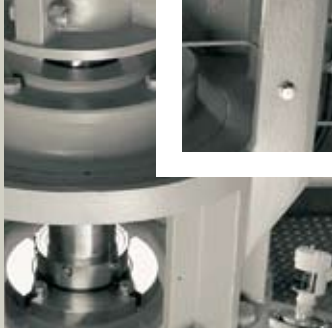

### Top entry installation

A top entry installation is generally used to seal the gas containing headspace.

It should be noted that the dynamic and stationary sealing elements on the product side can come into contact with splasher and foam from the tank. There is also a risk of polymerisation in gaps or in the dynamic sealing area.

The maximum speed, temperature and system pressure to be sealed in the reactor are important factors that affect the design. The mainly overhung agitator shafts are subject to bending stresses that cause the shaft to deflect in the seal plane. The mechanical forces that act on the shaft seal and bearing also have to be analysed carefully, as well as unwanted vibrations caused by internals that affect the flow or special cases, e.g. liquid bearing missing from the agitator.

Shaft deflections in the seal area of 0.1 mm to 0.3 mm are tolerated as standard, depending on the size of the drive system and agitator. Up to 2 mm is possible in special cases.

EagleBurgmann seal systems have proven successfully in many different applications.

#### Liquid-lubricated:

- EagleBurgmann M481  
Single or double seal with or without bearing for steel vessels
- EagleBurgmann M461  
Single or double seal with or without bearing for glass-lined vessels

May be equipped with cooling flange, leakage drain or polymerisation barrier to meet the process requirements.

**Glass-lined polymerisation reactor (Ekato) for producing ion exchanger granules at Lanxess Bitterfeld, Energizing Chemistry.**

**Medium:** Styrene copolymer, aromatics  
**Temperature:** 20 ... 150 °C  
**Pressure:**  $p_1$ : 0 ... 3 bar  
**Rotational speed:** 15 ... 50 min<sup>-1</sup>  
**Seal:** M481KL-D21/140-E1  
**Polymerisation barrier, ATEX zone 1**  
**Supply system:** TS2000/M226-D1  
**Barrier medium :** White oil  
**Barrier pressure:** Plan 53

#### Dry running, with contact of the seal faces:

- EagleBurgmann SeccoMix®  
Single seal with or without bearing
- EagleBurgmann SeccoMix®  
Double seal with or without bearing

#### Gas-lubricated without contact of the seal faces:

- EagleBurgmann AGSZ  
Double seal with or without bearing
- EagleBurgmann AGSR  
Double seal with rotating seat on the product side, with or without bearing





**Glass-lined stirred-tank reactor (EHW Thale) with top drive for producing various intermediate products for the pharmaceutical industry, for example. Used at Chemie AG Bitterfeld-Wolfen, Multi Purpose Center.**

**Temperature:** -10 ... 200 °C  
**Pressure:**  $p_1$ : -1 ... 6 bar  
**Rotational speed:** 30 ... 100 min<sup>-1</sup>  
**Seal:** M461 KL-D20/100-00  
**Supply system:** TS 1016/A007-00, Plan 53  
**Barrier medium :** White oil

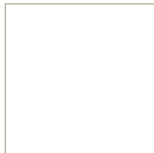
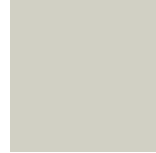

### DIN standard agitator drives

DIN 28161 "Requirements on agitator drives" covers the most important requirements on the seal. It defines speed limits, direction of rotation, bearing, running accuracy and the stuffing box dimensions for mechanical seals. The running accuracy of the agitator is defined in relation to the shaft diameter, but does not consider dynamic loads on the agitator shaft during mixing.

Within the DIN range EagleBurgmann supplies proven seal solutions tailored to different requirements, for steel or glass-lined vessels, e.g. the M4 ..., SeccoMix® and AGSZ series.

DIN 28161 applies to shaft diameters from 40 mm to 220 mm and a sliding velocity of up to 2 m/s, a pressure of -1 to 6 bar and a temperature from -25 °C to 200 °C.

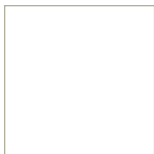

**Animal feed enzyme production at BASF Ludwigshafen. Stainless steel vessels with top entry agitator with sealed SeccoMix®**

**Medium:** Aqueous solution  
**Temperature  $t_1$ :** 5 ... 15 °C  
**Pressure  $p_1$ :** unpressurised  
**Rotational speed:** ... 45 min<sup>-1</sup>

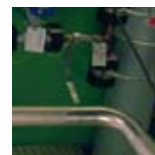



**Top entry stirred-tank reactor (Chema) in the HAS system at DOMO Caproleuna.**

**Medium:** Hydroxylammonium sulphate (HAS)  
**Temperature:** max. 200 °C  
**Pressure  $p_1$ :** 5 bar  
**Rotational speed:** 150 min<sup>-1</sup>  
**Seal:** M481KL-D20/180-A2  
**Supply system:** TS1016  
**Barrier medium:** Deionate (demineralised water)  
**Barrier pressure:** 7 bar



### Bottom entry installation

In contrast to top entry, it is the process medium itself which is sealed in a bottom entry installation. The rotating agitator shaft must be sealed off from the bottom of the tank and is totally immersed in the medium.

It is characteristic for this installation that deposits may form in the area of the dynamic and stationary sealing elements, depending on the process medium. These can then hang up the seal. Additionally, the seal directly faces the temperature of the process medium.

To cope with these tough operating conditions, mainly double seals with pressurised barrier medium are used. Other design features, such as flushing, may also be used. The materials must also be selected carefully. One decisive criterion in the choice of the barrier medium is its compatibility with the process medium.

As with the top entry installation, the maximum speed and temperature, the sealed system pressure in the vessel, the chemical requirements, the bending

stresses, the shaft deflection and the bearing must all be carefully analysed and evaluated.

EagleBurgmann sealing systems from the liquid-lubricated MR..., MR333 and HSHLU series and process-optimised gas-lubricated seals from the AGSR series have proven successfully for bottom entry installations.

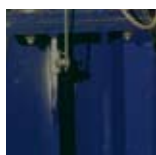
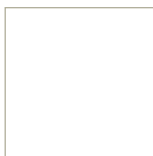

**Vitamin production at BASF Ludwigshafen. Homogenisers in a vacuum dryer.**

**Medium:** Vitamin pre-product  
**Temperature:** 200 °C  
**Pressure:** 1 ... 5 bar  
**Rotational speed:** 1,500 / 3,000 min<sup>-1</sup>  
**Seal:** HSMR1S24-D55/65-E1-A25

# Mechanical seals in mechanical and thermal separation processes



The equipment used in separation processes are often engineered designs, so the seals must be selected and designed particularly carefully. Top, bottom and side entry installations are all used. The forces acting on the seal during operation must be considered in detail in advance and must be taken into account in the seal design in order to guarantee an optimum sealing solution.

The emphasis in the seal design is placed on both the relatively high thermal loads (can be in excess of 300 °C) and the product deposits in the area of the dynamic and stationary

sealing elements on the product side. They must not prevent the seal from moving as required. Process-optimised seal design with rotating seals on the product side (MR series) have proved particularly successfully.

High temperatures can lead to considerable thermal expansion between the dryer drum and drive shaft. There can also be excessive relative movement, depending on whether the seal is installed on the "drive side" or the "non-drive side". These movements must be absorbed with metal bellows or special deflector systems. Such metal

bellows are designed for a specific type of dryer and the additional forces are taken into account.

EagleBurgmann seals can reliably fulfil the following process requirements:

- No contamination of the product
- Possibility of sterile operation
- The mechanical seal's functions are monitored by the supply system
- High MTBF

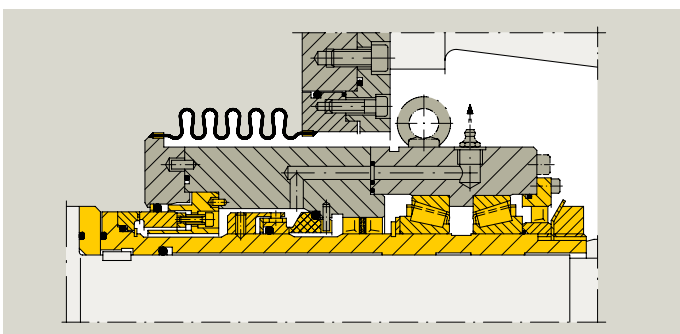

**HSMR1AL with metal bellows for compensating for large relative movements in a paddle dryer. Radial decoupling of the vessel / flange and shaft.**



**Spherical dryer (Rosenmund Guedu) for manufacturing pharmaceutical powders with HSMR5L-D.**

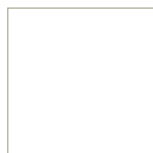

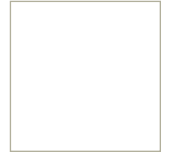
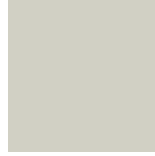
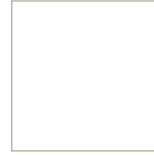

Examples of equipment used in mechanical and thermal separation processes:

### Nutsche filter (pressure nutsche filter)

Nutsche filters are used for the discontinuous filtration of suspensions with a relatively high solids content. They consist of a flat, cylindrical container with a horizontal filter surface. The modern types are equipped with agitators, which are generally height-adjustable. The filtration process is operated under overpressure or under

vacuum. The operating cycle for such a nutsche consists of the following steps:

- Filling the nutsche and filtration; the agitator distributes the suspension uniformly over the filter surface.
- Washing the filter cake
- Removal of the filter cake, e.g. by the agitator or by tilting the entire container

### Filter dryer (nutsche dryer)

The filter dryer is a variant of the nutsche filter that brings together the filtration and the cake drying, generally under vacuum, in a single apparatus with no product transfer. The agitator, tank walls and sometimes the tank base can be heated for drying. Filter dryers are used to process sensitive materials by gentle drying conditions to a low residual humidity.

### Conical dryer

This type of dryer is used primarily for bulk goods that must not stick or cake too much during drying. The material is circulated gently by a mixing screw which rotates both about its own axis and along the tank wall. The conical dryer can be operated under vacuum or under overpressure. Heat is supplied via the wall heater and additionally via the heated screw. There are variants with top drive or bottom drive design which has significant effects on the operational safety and the ability to empty the apparatus. One particular challenge for the sealing technology in bottom entry installation the sealing of two coaxial agitators moving at different speeds.



Filter dryer  
(Rosenmund Guedu,  
Switzerland)

Pressure nutsche filter  
(KHS) made of Hastelloy®  
and steel, for drying various  
intermediate products at  
Chemie AG Bitterfeld-Wolfen,  
Multi-Purpose Center.

Temperature: -10 ... 200 °C  
Pressure:  $p_1 = -1 \dots 6$  bar  
Rotational speed: 5 ... 6  $\text{min}^{-1}$   
Seal: HSMR35AL-D/170-E9,  
Supply system: Thermosiphon  
system, Plan 53  
Barrier medium : White oil



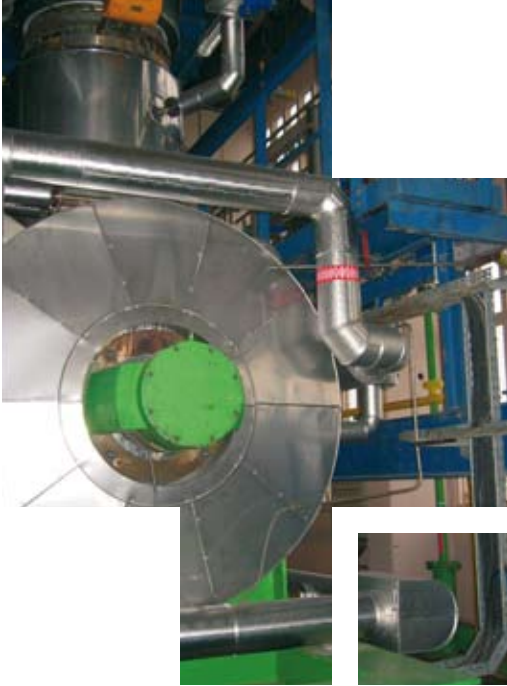

**Paddle-dryer (Lipp Mischtechnik), frequency-controlled, for producing and drying salicylic acid at Rhodia Syntec.**

**Medium:** Salicylic acid, various aromatics  
**Temperature:** 40 ... 220 °C  
**Pressure:** -1 ... 11 bar  
**Rotational speed:** 8 ... 80 min<sup>-1</sup>  
**Seals:** HSMR1AL-D/180-E1  
**Side drive, with 1 seal on drive and non-drive side**  
**Supply system:** Thermosiphon system  
**Barrier pressure:** Plan 53 with circulating pump

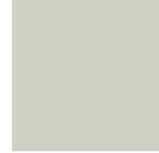

**Double cone dryer (rotary dryer)**

In a double cone dryer, the vessel is set in a tumbling motion by rotation. Thereby the product in the dryer is mixed and comes into contact with the heated wall. This ensures a good thermal transfer. Usually the double cone dryer is operated under a vacuum and is suitable for drying free flowing media. The internal space generally has no internals, so the apparatus is easy to empty and clean. Choppers are sometimes used to break up the product. In

this case the apparatus can sometimes be used to process paste-like media.

**Paddle-dryer**

Paddle-dryers are suitable for the discontinuous and continuous drying of pastes or free flowing media. A slowly-turning, generally heated shaft that is fitted with mixing paddles keeps the solids in movement. This intensive mixing means that even media that tend to stick together during drying can be processed. Choppers can also be used to break up the media. Smaller

apparatuses can often be opened at the end since the shaft is only mounted at one end. Large paddle-dryers can reach up to 20 m<sup>3</sup>, in which case the shaft will be mounted at both ends.

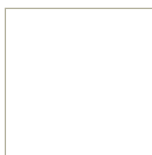

**Paddle-dryers (Lödige) for drying active ingredients for the pharmaceutical industry. Operator: Berg chemical works.**

**Medium:** Active ingredients for the pharmaceutical industry  
**Temperature:** 100 °C  
**Pressure:** Vacuum ... 0 bar  
**Rotational speed:** 32 min<sup>-1</sup>  
**Seal:** HSMR5S1-D2/120-E1  
**Side drive, with 1 seal on drive and non-drive side**  
**Supply system:** TS 1016 with 5000, plan 53  
**Barrier medium:** White oil



**Thin-film evaporator (Chema) in the caprolactam plant at DOMO Capro Leuna.**

**Medium:** Caprolactam  
**Temperature:** 200 °C  
**Pressure:** Vacuum  
**Rotational speed:** 150 min<sup>-1</sup>  
**Seal:** M45-D90/82  
**Central supply system:** SPA 4002/A03-D1  
**Barrier medium:** demineralised water  
**Barrier pressure:** 5 bar



**Thin-film evaporators**

are used to increase the concentration of high-viscosity products, to recover solvents and for temperature-sensitive materials under vacuum. Rotor blades distribute the liquid uniformly, which forms a thin film on the heated wall.

**Chopper**

Additional units in the form of cutters or rotor/stator systems can be integrated to accelerate mixing processes and to break up clumps. These “choppers” are generally arranged at the side, at the base of the tank. High speeds up to 3,000 min<sup>-1</sup> are reached. The MR5 as a double seal with pumping screw and with HS grooves, if necessary, has proven particularly successfully for this application.



**MR5LF-D with integrated bearing and directly attached chopper (mixing accelerator)**

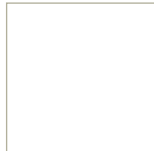

**Glass-lined polymerisation reactor (Ekato) for producing ion exchanger granules at Lanxess Bitterfeld, Energizing Chemistry.**

**Medium:** Styrene copolymer, aromatics  
**Temperature:** 20 ... 150 °C  
**Pressure:** p<sub>i</sub>: 0 ... 3 bar  
**Rotational speed:** 15 ... 50 min<sup>-1</sup>  
**Seal:** AGS481KL-D21/140-E4-U polymerisation barrier, Atex zone 0 (in the tank), zone 1 outside  
**Supply system:** GSS4016/A003 or GSS4016/A214  
**Barrier medium:** Air  
**Barrier pressure:** 9 bar



M481

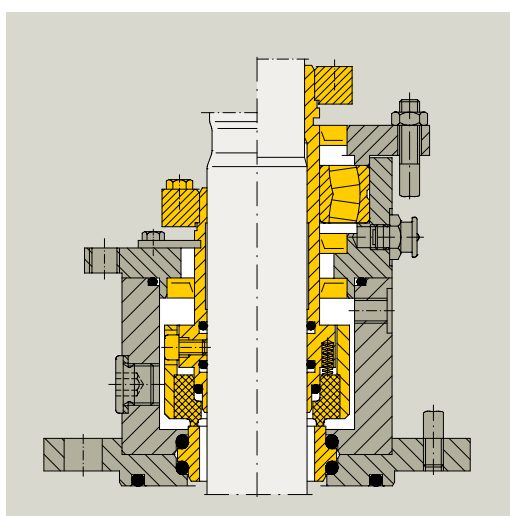
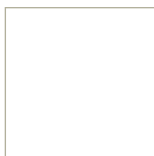

SeccoMix®  
single seals

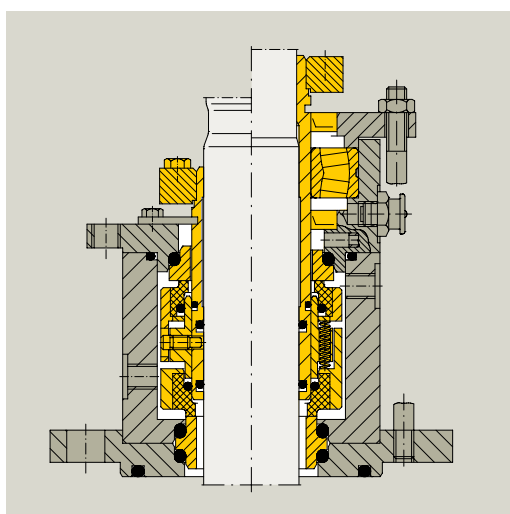
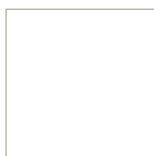

SeccoMix®  
double seals

## EagleBurgmann SeccoMix® and SeccoMix® 481

- Dry-running mechanical seals
- FDA approved

Specific face material combinations allow dry-running with contact of the seal faces. The grade of carbon used in the seal face is FDA-conform. For use in pharmaceutical applications, the seal can be equipped on request with a collecting cup (CIP). The SeccoMix® as a single seal does not need a supply system.

With a single seal, the process gas is dissipated to the atmosphere or can be diverted into drainage system. If any leakage into the atmosphere is not permitted, a SeccoMix® double seal should be used. This should be pressurised with a barrier gas (preferably N<sub>2</sub>) and a barrier pressure of 0.5 to 1.0 bar above the pressure to be sealed. The hydraulic conditions ensure that the seal is closed by both the product pressure and a superimposed barrier pressure.

Agitator seals from the SeccoMix® series are available as components or as factory-tested cartridge units (SeccoMix 481). Connections for steel (SeccoMix 481) and glass-lined (SeccoMix 461) reactors are available to DIN standards or as required.

## Operating limits

### SeccoMix® (cartridge units)

$d_1 = 25 \dots 220 \text{ mm}$  (0.984 ... 8.661")  
 $p_1 = \text{vacuum} \dots 6 \text{ bar}$  (87 PSI)  
 $t_1 = -20 \dots +150$  (200) °C  
 (-4 ... 302 (392) °F)  
 $v_g = 2 \text{ m/s}$  (6 ft/s)  
 Perm. axial movement:  $\pm 1.5 \text{ mm}$   
 Radial movement:  $\pm 2 \text{ mm}$

### SeccoMix® (component seals)

$d_1 = 25 \dots 160 \text{ mm}$  (0.948 ... 6.229")  
 $p_1 = \text{vacuum} \dots 6 \text{ bar}$  (87 PSI)  
 $t_1 = -20 \dots +150$  (200) °C  
 (-4 ... 302 (392) °F)  
 $v_g = 2 \text{ m/s}$  (6 ft/s)  
 Perm. axial movement:  $\pm 1.5 \text{ mm}$   
 Radial movement:  $\pm 2 \text{ mm}$



SeccoMix®  
component seal





# agitator seals – the complete range

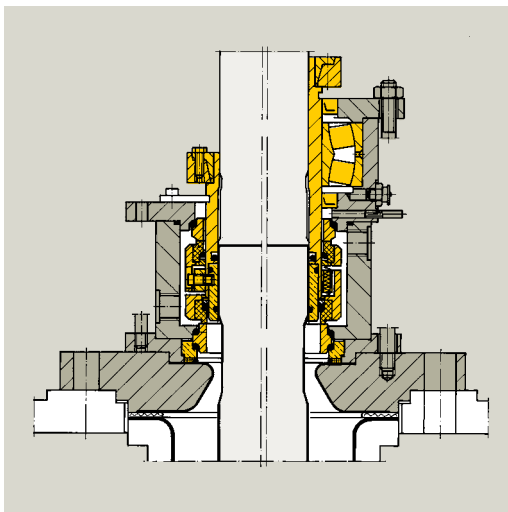
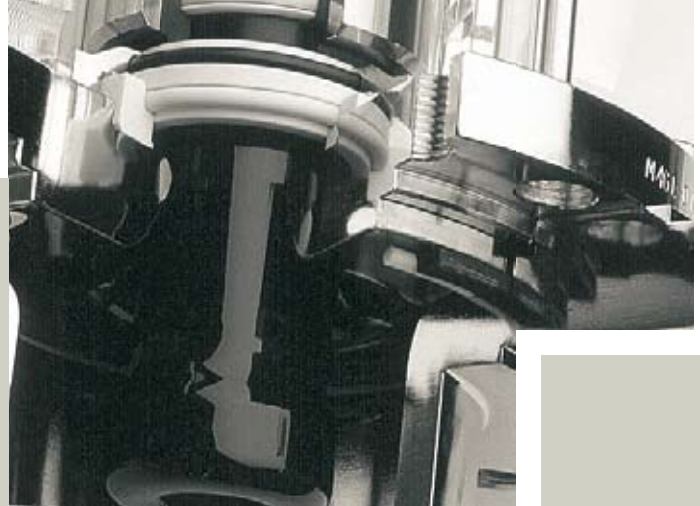

**M461**  
for glass-lined  
vessels

## EagleBurgmann M461 and M481

- Liquid-lubricated mechanical seals
- according to DIN 28136 and DIN 28138
- for steel and glass-lined vessels
- FDA approved

The seals can be used for a wide range of applications, and may be used as single or multiple seals with an unpressurised liquid reservoir (quench) or pressurised with a supply system (TS1016 or TS2000). With the double seal, the operating limits are far higher than the pressures and speeds defined in the DIN standards. Agitator seals from the M461 and M481 series are supplied in the form of factory-tested cartridge units.

The hydraulic conditions ensure that the seal is closed by both the product pressure and a superimposed barrier pressure.

### Operating limits according to DIN 28138 T2

$d_1 = 40 \dots 220 \text{ mm}$  (1.575 ... 8.661")  
 $v_g = 2 \text{ m/s}$  (6 ft/s)  
 $p_1 = \text{vacuum} \dots 6 \text{ bar}$  (87 PSI)  
 $t_1 = -25 \dots +200 \text{ }^\circ\text{C}$  (-13 ... 392 °F)

### EagleBurgmann operating limits

(depends on the choice of materials and the supply system)  
 $d_1 = 40 \dots 220 \text{ mm}$  (1.575 ... 8.661")  
 $v_g = 5 \text{ m/s}$  (16 ft/s)  
 $p_1 = \text{vacuum} \dots 16 \text{ bar}$  (232 PSI)  
 $t_1 = -80 \dots +200 (+350) \text{ }^\circ\text{C}$   
 (-112 ... 392 (662) °F)

Suitable options include cooling or heating flange, polymerisation barrier, leakage drain and cleanability for use in pharmaceutical applications. The materials used are extremely flexible, so practically all requirements can be met with the standard design variants.

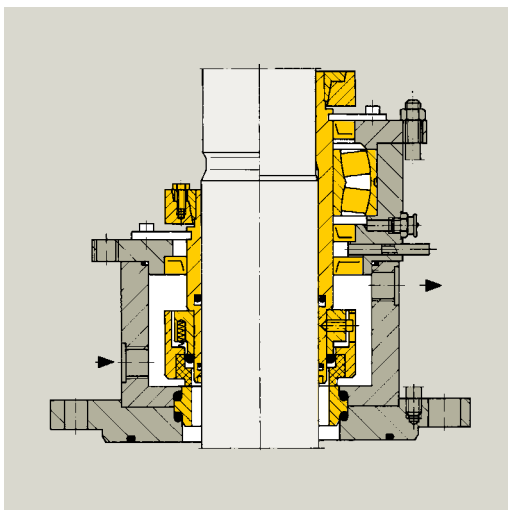

**M481**  
for steel and  
stainless steel  
vessels

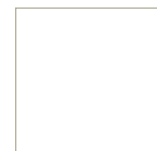

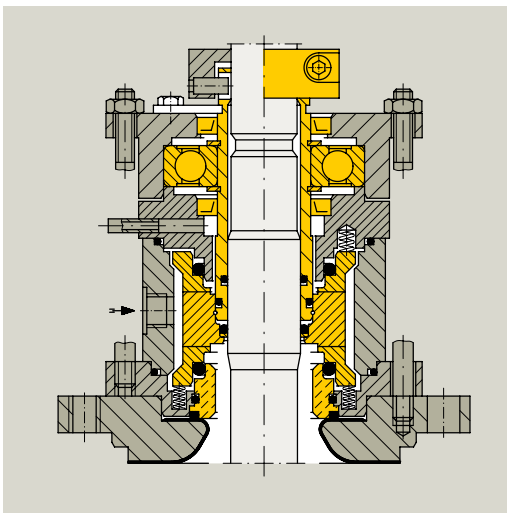

AGSZ 461

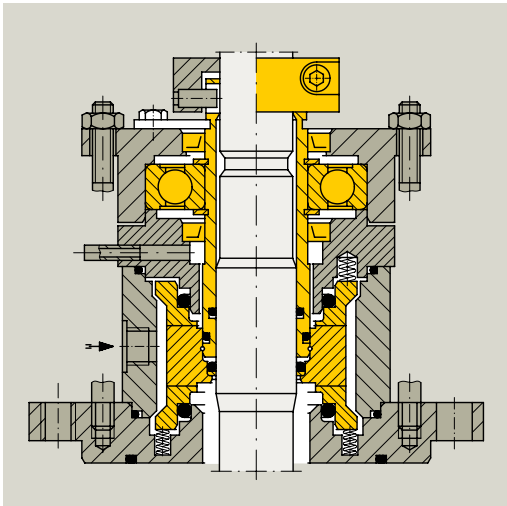

AGSZ 481

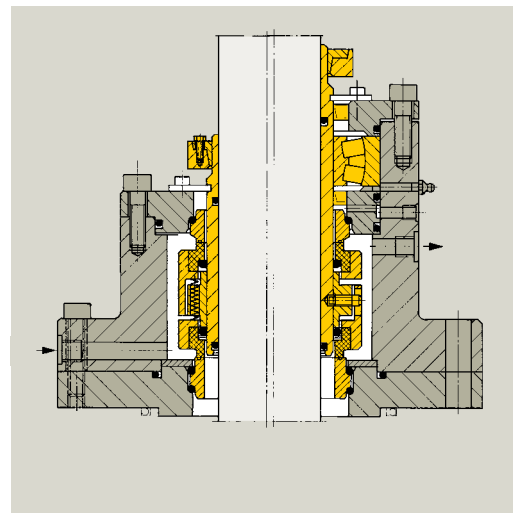

HS-D

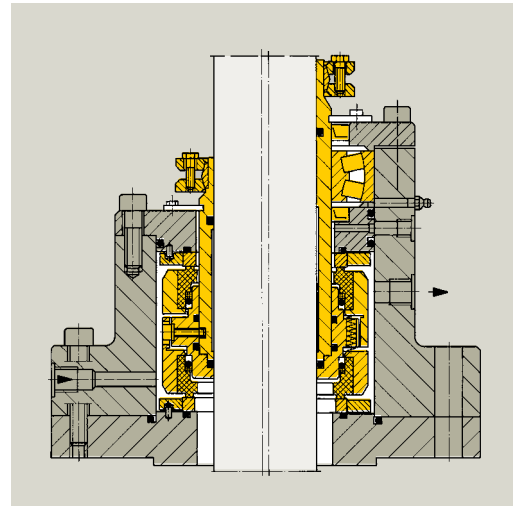

HSH-D

### EagleBurgmann AGSZ 461 and AGSZ 481

- Gas-lubricated, contact-free mechanical seals
- according to DIN 28136 and DIN 28138
- for steel and glass-lined vessels

The AGSZ is not sensitive to radial deflection. A centrally rotating seat, stationary spring-loaded seal face and an integrated bearing, which acts at the same time as a fixed bearing for the seal and as a floating bearing for the shaft, provide effective protection against negative influences on operation.

An optimum sealing gap stiffness ensures that the seal operates reliably without contact, even under tough operating conditions. Agitator seals from the AGSZ series are supplied in the form of factory-tested cartridge units.

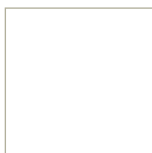

### AGSR ... for sterile applications in the pharmaceutical industry

The "R" in AGSR stands for a rotating seat on the product side. The AGSR is particularly suitable for applications in the pharmaceutical, biotech and food industry. If certain requirements are fulfilled and with a few additional design features, the seal can also be used in direct contact with the product.

#### Supply system for AGSZ... and AGSR...

A supply system from the GSS series is needed for operation. A gas network connected upstream is sufficient to supply gas and pressure. The necessary barrier pressure must be 3 bar higher than the process pressure to be sealed. The aerostatic design ensures that the gas consumption is approximately the same across the whole operating range.

#### Operating limits

$d_3 = 40 \dots 220 \text{ mm}$  (1.575 ... 8.661")  
 $p_1 = \text{vacuum} \dots 10 \text{ bar}$  (145 PSI)  
 $t_1 = -30 \text{ (-80)} \dots +200 \text{ (+250)} \text{ }^\circ\text{C}$   
 (-22 (-112) ... 392 (482)  $^\circ\text{F}$ )  
 $v_g = 10 \text{ m/s}$  (32 ft/s)

### EagleBurgmann HS-D and HSL-D

- Agitator seal up to 40 bar
- with integrated bearing

Mechanical seals of the HS series can be equipped with additional design features, such as cooling and heating flange, polymerisation barrier, leakage drain and cleanability for use in pharmaceutical operations. The materials used are extremely flexible, so practically all requirements can be met. The connection sizes are matched to individual requirements.

The dual seals are operated with a supply system. To run perfectly, the sliding faces are equipped with EagleBurgmann patented hydrodynamic grooves, which provide an optimum lubrication with minimal load on the sliding faces. These features ensure that the HS series is highly reliable and has a long service life.

#### Operating limits

$d_1 = 20 \dots 500 \text{ mm}$  (0.787 ... 19.68")  
 $p_1 = \text{vacuum} \dots 40 \text{ bar}$  (580 PSI)  
 $t_1 = -30 \dots +200 \text{ (+350)} \text{ }^\circ\text{C}$   
 (-22 ... 392 (662)  $^\circ\text{F}$ )  
 $v_g = 5 \text{ m/s}$  (16 ft/s)

### EagleBurgmann HSHL-D and HSH-D

- Agitator seal up to 250 bar
- with integrated bearing

Agitator seals of the HSH-D series are specially designed for high-pressure applications. They are engineered solutions with connection sizes matched to the specific application. The seals are operated with a supply system.

Combined with hydrodynamic grooves, these seals offer minimal load on the sliding faces, optimum formation of a lubricating film, high reliability and a long service life.

#### Operating limits

$d_1 = 20 \dots 350 \text{ mm}$  (0.787 ... 13.78")  
 $p_1 = \text{vacuum} \dots 250 \text{ bar}$  (3,625 PSI)  
 $t_1 = -30 \dots +200 \text{ (+350)} \text{ }^\circ\text{C}$   
 (-22 ... 392 (662)  $^\circ\text{F}$ )

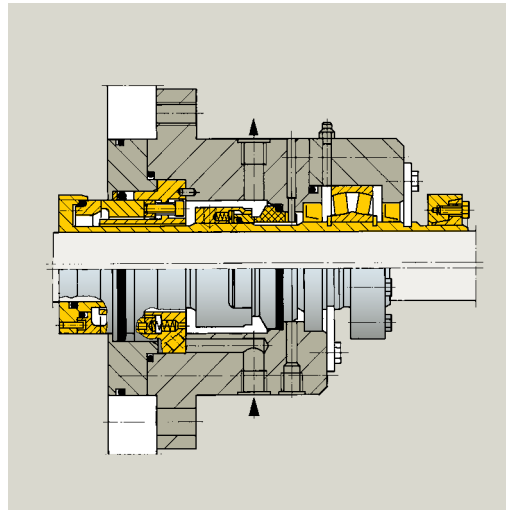

MR-D (standard)

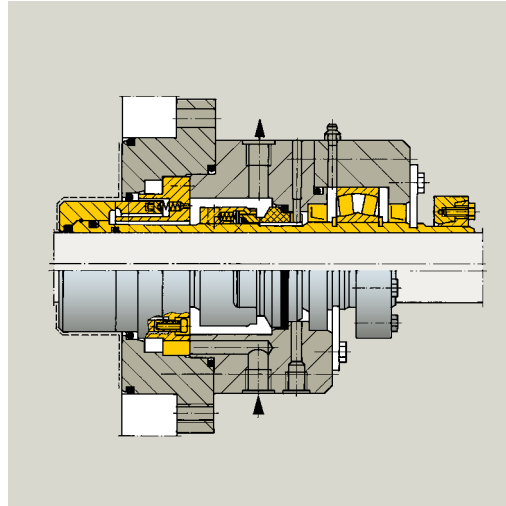

MR-333 (for sterile applications)

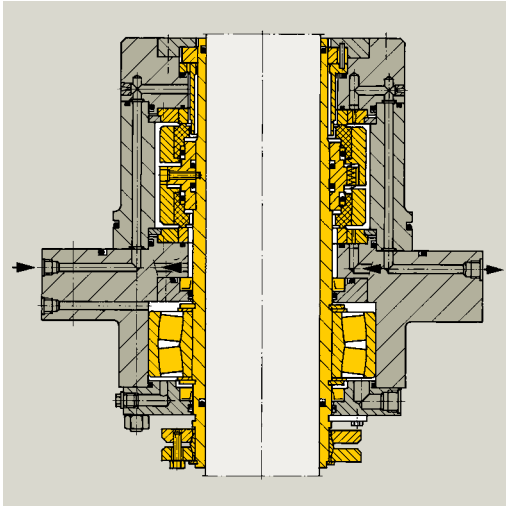

HSHLU-D

### EagleBurgmann HSHLU-D

- Agitator seal up to 60 bar
- for bottom entry installation

Agitator seals of the HSHLU-D series are typically used for bottom entry applications such as plastics production. The seals are fully immersed in the process medium and are subject to extreme stresses. On the product side, floating throttle rings with flush prevent the intrusion of medium (e.g. polymer powder) into the seal area. The double acting seals are operated with a supply system.

#### Operating limits

$d_1 = 20 \dots 400 \text{ mm}$  (0.787 ... 15.748")  
 $p_1 = \text{vacuum} \dots 60 \text{ bar}$  (870 PSI)  
 $t_1 = -30 \dots +200 \text{ }^\circ\text{C}$  (-22 ... 392 °F)

### EagleBurgmann MR

- Mechanical seal for chemical and pharmaceutical applications
- for adhesive, paste-like and dry media

Agitator seals of the MR series are ideal for use with adhesive, paste-like and dry media in agitators and all types of mixers, dryers, kneaders and reactors in the plastics, dyestuffs, food and pharmaceutical industry.

Building on many years' practical experience and through the use of the latest face materials, MR seals can be found operating successfully in almost all applications. The rotating seat on the product side is an outstanding design feature.

The MR333 version of the seal fulfils all the criteria for sterile processes: surfaces on the product side are polished, smooth and free of gaps, CIP/SIP compliant and conform to FDA guidelines. They can be equipped with aseptic connections, e.g. to DIN 11851.

Connection sizes are matched to individual requirements.

The double acting seals are operated with a supply system.

#### Operating limits

$d_1 = 20 \dots 200$  (500) mm  
 (0.787 ... 7.874 (19.68)")  
 $p_1 = \text{vacuum} \dots 23 \text{ bar}$  (333 PSI)  
 $p_3 = 25 \text{ bar}$  (362 PSI)  
 $\Delta p (p_3 - p_1) \text{ max. } 10 \text{ bar}$  (145 PSI),  
 min. 2 bar (29 PSI)  
 $t_1 = -30 \dots +300 \text{ }^\circ\text{C}$  (-22 ... 572 °F)  
 $v_0 = 20 \text{ m/s}$  (65 ft/s)



MR-D

# EagleBurgmann supply systems

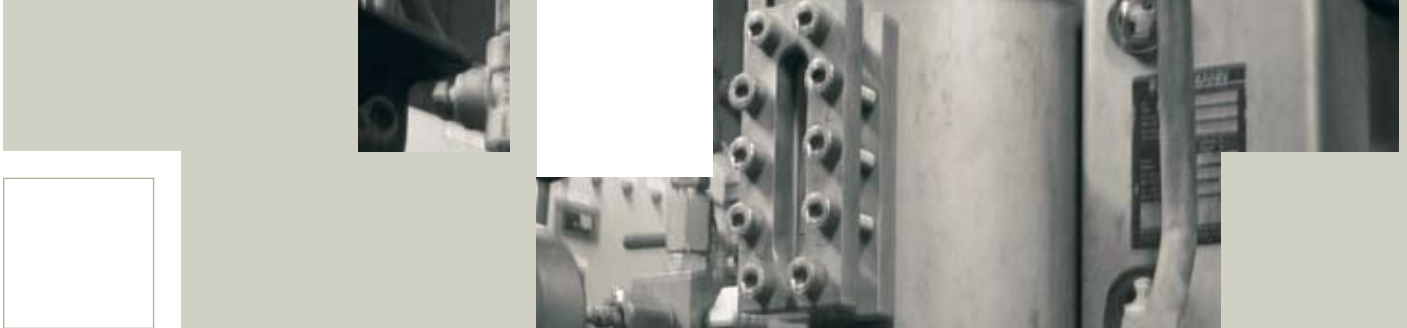

Glass-lined agitated tank for producing various intermediate products. Sealed with AGS, supplied with nitrogen via GSS4016 (background) and SP25 pressure booster pump (foreground).

Depending on the type of equipment in which they are used, and on the medium, mode of operation and environmental protection requirements, etc, agitator seals may need additional design features to ensure efficient operation.

As the requirements on mechanical seal increase, their design, mode of operation and ultimately their supply systems are changing. The following pages show the most commonly used and proven supply systems used in state of the art sealing technology for agitator seals.

## Barrier or quench systems for liquid-lubricated single and multiple mechanical seals

Mechanical seals can only be guaranteed to work efficiently if the space between the product and atmosphere side of the mechanical seal is completely filled with clean medium. The liquid reservoir may be un-pressurised or pressurised.

## Quench system

Quench is the term commonly used in sealing technology for an arrangement that applies an un-pressurised external medium (liquid) to a mechanical seal's sliding faces. The quench performs at least one of the following tasks:

- Absorption or removal of leakage by the quench medium
- Monitoring of the mechanical seal's leakage rate by periodic measurement of the level of the quench medium in the circulation vessel or thermosiphon vessel
- Preventing of the contact between leakage and atmosphere for media which react undesirably with oxygen
- Protection against dry running
- Cooling
- Lubrication

## Supply systems

Supply systems for liquid-lubricated mechanical seals can essentially be divided into two types:

### Open circuit: Buffer fluid system

A circuit which provides both circulation and pressurisation via a supply system (e.g. EagleBurgmann SPA). The barrier medium is depressurised after it has circulated and is collected in an un-pressurised tank.

### Closed circuit: Thermosiphon system / pressure booster or cooling circuit with refill unit

Here, all the components are under the same pressure. They are pressurised via an external pressure source or nitrogen (TS system) via a refill system (SPN) or by the process pressure (DRU system).

Before double seals start-up it is vital, to ensure a sufficient rate of circulation of the barrier liquid. The barrier liquid pressure should be 10 % or at least 1.5...2 bar above the maximum pressure to be sealed. To ensure that the sliding faces are lubricated well, the outlet temperature of the barrier medium must be regulated via the flow rate so that the boiling point of the barrier medium in the sealing gap is not exceeded at atmospheric pressure. The maximum acceptable inlet/outlet temperature differential is 15 K. The barrier liquid outlet is situated at the highest point of the seal chamber for automatic venting of any vapour.

The basic operating conditions define the following functions of the supply system:

- Build-up pressure in the barrier interspace
- Compensation of leakage
- Circulation of the barrier medium
- Cooling of the barrier medium
- Cooling of the seal
- Lubricating of the sliding faces

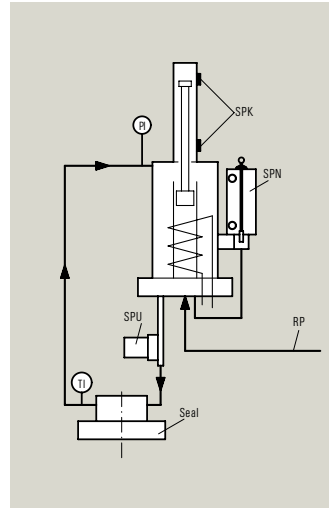
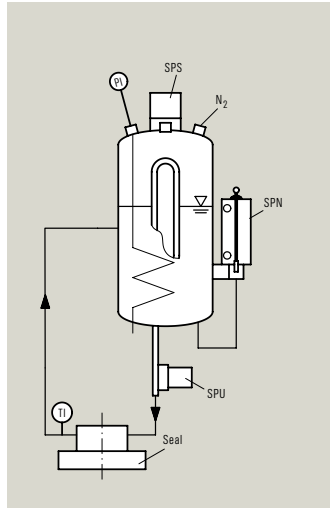
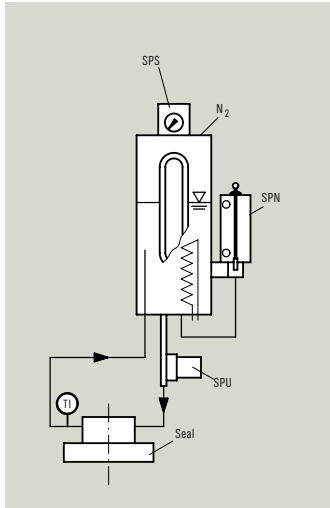

### EagleBurgmann TS 1016 Thermosiphon system

Pressure vessel with flat bottom and incorporated cooling coil and sight-glass for level control.

Perm. operating temperature  
-60 ... +120 (200) °C  
(-76 ... 248 (392) °F)  
Perm. operating pressure 18 bar  
(261 PSI)

### EagleBurgmann TS 2000 Thermosiphon system

Pressure vessel with torispherical heads and incorporated cooling coil and sight-glass for level control.

Perm. operating temperature  
-60 ... +200 °C (-76 ... 392 °F)  
Perm. operating pressure 30 bar  
(435 PSI) (TS 2000),  
63 bar (913 PSI) (TS 2063)



### EagleBurgmann DRU Pressure booster system

With the DRU system it is possible to supply barrier fluid to double seals for a wide range of applications. It works similar than the TS system but, in this case, the barrier pressure is generated by the reference pressure (e.g. tank pressure) without additional superimposed nitrogen.

Perm. operating temperature  
-60 ... +200 °C (-76 ... 392 °F)  
Perm. operating pressure 63 bar  
(913 PSI) (DRU2063)  
Transmission ratio 1:1.1 or 1:1.5



## Thermosiphon systems

The EagleBurgmann TS system TS 1016 or TS 2000 is used to supply barrier fluid to double and tandem seal arrangement for a wide range of applications. TS vessels are equipped as standard with all the necessary connections and brackets. Additional components (e.g. circulating and refill pumps, measuring equipment, level switches and valve groups) may be installed as required. The vessel is used for storage, pressure maintenance and cooling of the quench or barrier liquid in the sealing circuit.

Design, construction and production according to the EU Pressure Equipment Directive 97/23/EC. All pressure-loaded welds are butt-welded or counter butt-welded by MIG and TIG process. Sockets with recessed gasket (no contamination of the circuit by thread sealant). Cooling water connections at top (Out) and bottom (In) for venting and draining.



supply system SPA  
2000 for supplying  
an M481

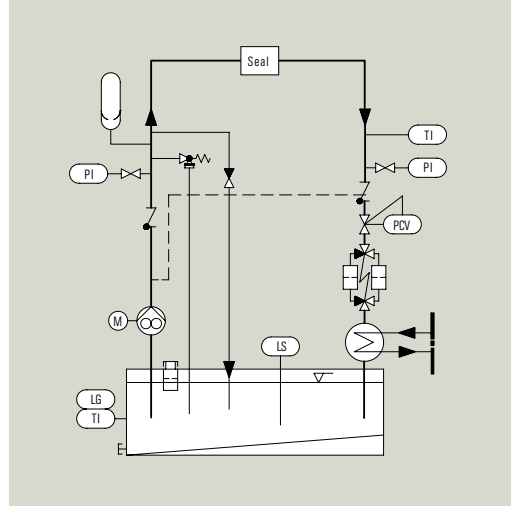

### Barrier pressure systems of the SPA series

The basic version performs and fulfils all four tasks of a supply system essential for operating double seals: Circulation and cooling of the barrier medium, pressurisation of the barrier medium and compensation of leakage. EagleBurgmann SPA units have a high quality standard, are easy to operate and maintain, and are adaptable and rugged. Their function is based on the principle of the open circuit.

### Supply systems of the SPN series with SPU

These are automatic refill units with pressure switch (SPN 1000 series) or pressure control valve (3000 series) for manual barrier pressure regulation. The pressure control valve (SPN 3000 series) allows a constant barrier pressure irrespective of hysteresis-induced pressure fluctuations (hysteresis of the pressure switch). Temporary maintaining of the barrier pressure when the pump is switched off by the accumulator. Several outputs can be provided for setting different barrier pressures. The basic version of the automatic refill unit SPN only performs two of the four tasks of a barrier system, compared to an

SPA: pressurisation of the barrier medium and compensation of leakage. The energy needed for pressurisation (piston pump) is supplied via a pneumatic and an electric drive, either in combination or individually. Separate components are installed in the seal barrier circuit to cool and circulate the barrier medium.

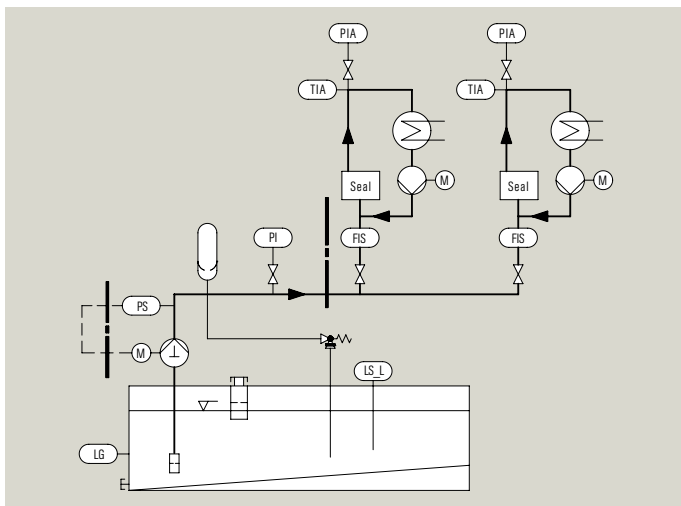
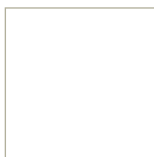

SPN 3000 with  
electric drive



**SPA 4002 for supplying 12 agitator seals on thin-film evaporators at DOMO Caproleuna.**



**SPA 4015**



**GSS 4016**

**EagleBurgmann supply systems GSS 4016 for gas-lubricated, pressurised agitator seals.**

Gas-lubricated mechanical seals may only be operated if the barrier pressure is high enough. At any operating condition the barrier pressure  $p_3$  must be at least 3 bar higher than the product pressure  $p_1$  to be sealed. Gas supply systems of the GSS series are specially designed for dry running and gas-lubricated mechanical seals.



Important GSS functions:

- Filtering of the barrier and flush gas
- Pressure monitoring and pressure regulation
- Flow rate monitoring
- Control and drainage of the leakage

A single connection to the gas supply (or cylinder with pressure reducer) with an upstream EagleBurgmann GSS 4016 gas supply and control system is sufficient to operate the gas-lubricated agitator seals. We recommend the application of the GSS 4016 gas supply system with two flow meters (FIAH, FIAL) and a pressure monitoring unit (PIAL).

**Key**

- FIS Flow switch with indicator (sight-glass)
- LG Level indicator
- LS Level switch
- LS-L MIN level switch
- M Motor
- N2 Nitrogen
- PCV Pressure control valve
- PI Pressure gauge
- PIA Contact pressure gauge
- PS Pressure switch
- RP Reference pressure
- TI Thermometer
- TIA Contact thermometer

**EagleBurgmann components:**

- SPK Contact device
- SPN Manual refill pump / refill unit
- SPS Level switch
- SPU Circulating pump

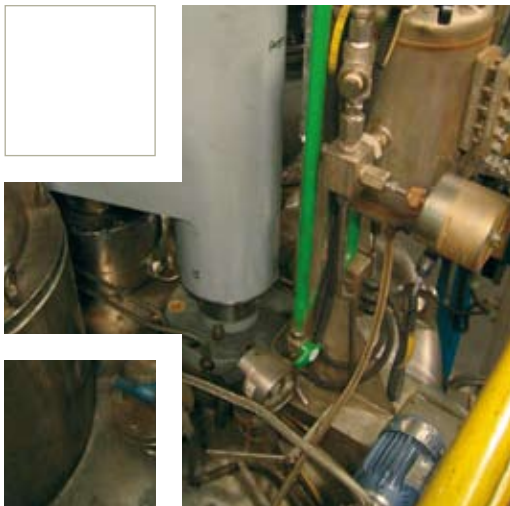

**Pressure nutsche filter (Gedue) in the HAS plant at DOMO Caproleuna.**

**Medium: HAS, catalyst**  
**Temperature: 200 °C**  
**Pressure: Vacuum**  
**Rotational speed: ... 20 min<sup>-1</sup>**  
**Seal: HSSMR35AL-D/170-E8**  
**Supply system: TS2000 + SPU2040**  
**Barrier medium: Deionate (demineralised water)**  
**Barrier pressure: 5 bar**

# EagleBurgmann in your vicinity

## Argentina

EagleBurgmann Argentina  
Catalina M. de Boyle, 3117  
(Calle 28)  
San Martin - Buenos Aires  
Phone +54 11 47 54 63 50  
Fax +54 11 47 54 63 73

## Chilicote S.A.

Avda. Julio A. Roca 546  
C1067 ABN Buenos Aires,  
Argentina  
Phone +54 / 11 / 43 43 84 69  
Telefax +54 / 11 / 43 31 42 78

## Australia

EagleBurgmann Australia Pty. Ltd.  
16 Slemmet Road,  
Ingleburn, NSW 2565  
Phone +61 / 2 / 96 05 64 44  
Telefax +61 / 2 / 98 29 69 58

## Austria

EagleBurgmann Austria GmbH  
Vogelweiderstraße 44 a  
A-5020 Salzburg  
Phone +43 / 662 / 82 57 01  
Telefax +43 / 662 / 82 57 03

## Belarus

Filter CJSV  
Logpisky tract and MCAD crossing  
Administrative building  
Expobell - Office 501  
223053 Minsky district  
Phone +375 17 237 9365  
Telefax +375 17 237 9363

## Belgium

EagleBurgmann Belgium B.V.B.A.  
Zagerijstraat 11  
B-2960 Sint-Jobbe-in't-Goor  
Phone +32 / 3 / 6 33 99 44  
Telefax +32 / 3 / 6 33 99 49

## Brazil

EagleBurgmann do Brasil  
Vedapços Industriais Ltda.  
Av. Sta. Izabel, 1721  
CEP - 13084-643 Barao Geraldo  
Caixa Postal 65 60  
Campinas - Sao Paulo  
Phone +55 / 19 / 37 49 97 40  
Telefax +55 / 19 / 37 49 97 42

## Canada

EagleBurgmann Canada Inc.  
8699 Escarpment Way,  
Units #9 & #10  
Milton, Ontario / Canada L9T 0J5  
Phone +1 / 905 / 693 87 82  
Telefax +1 / 905 / 693 05 35  
Nova Magnetics-Burgmann Ltd.  
One Research Drive  
Dartmouth, Nova Scotia  
Canada B2Y 4M9  
Phone +1 / 902 / 465 66 25  
Telefax +1 / 902 / 465 66 29

## Chile

SelloTecnico Ltda.  
Luis Thayer Ojeda No. 0130  
OF 806 Providencia Santiago  
Chile  
Phone +56 / 2 / 333 33 03  
Telefax +56 / 2 / 333 25 19

## China

Burgmann Shanghai Ltd.  
No. 127-8 Wenjing Road  
Minhang, Shanghai  
People's Republic of China  
Phone +86 / 21 / 64 62 05 50  
Telefax +86 / 21 / 64 30 02 19

Burgmann Dalian Ltd.  
No. 86 Liaohé East Road, DD Port  
116820 Dalian  
People's Republic of China  
Phone +86 / 411 8758 1000  
Telefax +86 / 411 8758 1418

EBI (Shanghai)  
Investment Management Co. Ltd.  
Room 205 B Cinic Tower  
No. 1090 Century Ave. Pudong  
201120 Shanghai  
People's Republic of China  
Phone +86 21 58 36 15 99  
Telefax +86 21 58 35 48 38

## Colombia

William Tobon & Cia.  
Cr. 7 - 64 - 50 - Ext. 301  
Santafé de Bogotá  
Phone +57 / 1 / 211 76 75  
Telefax +57 / 1 / 211 76 75

## Cyprus & Lebanon

TRCI Ltd.  
122, Limassol Ave. PO Box 24371  
1703 Nicosia, Cyprus  
Phone +357 22 42 79 80  
Telefax +357 22 42 30 21

## Czech Republic

EagleBurgmann Czech s.r.o.  
Na Drahač 1364  
CZ-15600 Praha 5 Zbraslav  
Phone +420 / 2 / 57 92 05 05  
Telefax +420 / 2 / 57 92 05 08

KE-Burgmann Czech s.r.o.  
V Lázních 395  
CZ-254 01 Jihočev v Práhy  
Phone +420 / 2 / 41 02 18 11  
Telefax +420 / 2 / 41 02 18 30

## Denmark

KE-Burgmann A/S  
Expansion Joints Division  
Park Allé 34,  
DK-6600 Vejlen  
Phone +45 / 75 36 18 11  
Telefax +45 / 75 36 15 32

## KE-Burgmann A/S

Seals Division  
Industrisvinget 1,  
DK-6600 Vejlen  
Phone +45 / 75 36 49 88  
Telefax +45 / 75 36 39 88

## KE-Burgmann Bredan A/S

Odinsvej 1, Box 129  
DK-6950 Ringkøbing  
Phone +45 / 96 74 28 00  
Telefax +45 / 97 32 36 31

## Ecuador

Petroconsultant S.A.  
Fco. de Goya 262  
Urb. Los Cipreses II  
El Condado  
P.O. Box 17-17-1524, Quito  
Phone +593 / 2 / 49 17 52  
Telefax +593 / 2 / 49 35 09

## Egypt

Alimex Alexandria  
Import Export  
258 Abdel Salam Aref Str.  
Louran - El Saray  
Alexandria POB 313  
Phone +20 / 3 / 5 81 00 60  
Telefax +20 / 3 / 5 81 00 65

## Estonia

Filter AS  
Läike tee 9, Peetri Küla, Rae vald,  
EE-75312 Harjumaa  
Phone +00372 742 24 29  
Telefax +00372 512 012 0

## Finland

KE-Burgmann Finland Oy  
Expansion Joints  
P.O. Box 139, Ensimmäinen Saven  
SF-01510 Vantaa  
Phone +358 / 9 / 82 55 01  
Telefax +358 / 9 / 82 55 02 00

## Tiivistetekniikka Oy

Mäkituvantie 5,  
SF-01510 Vantaa  
Phone +358 / 207 65 171  
Telefax +358 / 207 65 20 07

## France

EagleBurgmann France SAS  
Zone d'Activité les Perriers  
106/108 Route de Cormeilles  
BP 96,  
F-78505 Sartrouville  
Phone +33 / 1 / 30 86 50 20  
Telefax +33 / 1 / 39 15 16 07

## Germany

Burgmann Industries  
GmbH & Co. KG  
Außere Sauerlacher Str. 6-10  
D-82515 Wolfratshausen  
Phone +49(0)8171/23-0  
Telefax +49(0)8171/23-1214  
www.eagleburgmann.com

## Espey Burgmann GmbH

Thomas-Edison-Str. 19  
D-47445 Moers  
Phone +49 / 2841 / 99827-0  
Telefax +49 / 2841 / 99827-55

## Great Britain

EagleBurgmann Industries  
UK LP  
12, Welton Road  
Wedgcock Industrial Estate  
GB-Warwick CV 34 5PZ  
Phone +44 / 1926 / 41 76 00  
Telefax +44 / 1926 / 41 76 17

## KE-Burgmann U.K.

Eaton Bank, Congleton  
GB-Cheshire SW12 1NZ  
Phone +44 / 1260 / 29 12 89  
Telefax +44 / 1260 / 29 13 03

## Greece

A.G. Stambolidis & Co.  
Mitrodorou 22  
GR-10441 Athen  
Phone +30 / 21 / 05 15 06 65  
Telefax +30 / 21 / 05 15 08 10

## Hungary

EagleBurgmann Hungaria Kft.  
Lejtó utca 6  
H-1124 Budapest  
Phone +36 / 1 / 3 19 81 31  
Telefax +36 / 1 / 3 19 81 25

## India

Burgmann India PVT. LTD.  
A.K. Industrial Estate  
Madina Manzil Compound  
S.V. Road, Goregaon (West)  
Bombay 400 062  
Phone +91 / 22 / 28 74 15 34  
Telefax +91 / 22 / 28 74 88 10

Eagle Seals & Systems India Ltd.  
21/2, Hadapsar  
Off. Soil Poonawalla Road  
Guns 411 028 India  
Phone +91 / 20 / 2699 3900  
Telefax +91 / 20 / 2699 3921

## KE-Burgmann

Flexibles India Pvt. Ltd.  
Survey No. 1426  
Calzada de Guadalupe  
G.N.T. Road, Puzhal  
Chennai 600 086, India  
Phone +91 / 44 / 6 59 06 32  
Telefax +91 / 44 / 6 59 09 17

## Indonesia

PT EagleBurgmann Indonesia  
Jl. Jababeka Blok J6-E  
Kawasan Industri Cikarang  
Bekasi 17550 - Jawa Barat  
Phone +62 / 21 / 8 93 53 13  
Telefax +62 / 21 / 8 93 53 15

## Irak

WTE  
Ukba Sq., Mahala 929  
Zuhak 2, House No. 5  
P.O. Box No. 2421  
Al Jadria, Baghdad  
Phone +964 171 99033  
Telefax +964 171 93034

## Iran

Burgmann Pars  
Sealing Systems Co.  
No. 1, Kokab Alley,  
Pasdaran Ave.  
Teheran  
Phone +98 / 21 / 2 86 28 19  
Telefax +98 / 21 / 2 85 44 81

## Israel

ETA Engineering Ltd.  
P.O. Box 890  
Ramat-Gan 52108  
18 Tushia St.  
Phone +972 / 3 / 6 24 19 45  
Telefax +972 / 3 / 5 62 84 75

## Italy

EagleBurgmann Italia s.r.l.  
Viale Martiri della Liberazione, 12  
I-23875 Osnago (LC)  
Phone +39 / 039 / 95 22 501  
Telefax +39 / 039 / 928 94 83

## BT-Burgmann S.P.A.

Via Meucci, 58  
I-36057 Arcugnano (Vi)  
Phone +39 / 0444 / 28 89 77  
Telefax +39 / 0444 / 28 86 93

## Japan

Eagle Industry Co., Ltd.  
General Industry Overseas  
Sales Dept.  
Marketing & Sales Division  
1-12-15, Shiba-Daimon, Minato-ku  
Tokyo, 105-8587  
Phone +81 / 3 / 3432-4771  
Telefax +81 / 3 / 3438-2370

## Jordan

Eman Essa Trading Est.  
P.O. Box 840067  
Amman 11180  
Phone +96 / 279 / 5 57 66 92  
Telefax +96 / 265 / 66 56 96

## Kazakhstan

Globe Interstar  
Furmanova Street 240, Office 18  
050059 Almaty  
Phone +7 / 327 / 264 34 86  
Telefax +7 / 327 / 264 33 82

## Korea

EagleBurgmann Korea Co. Ltd.  
541, Suwolnam-Ri, Seotan-Myn  
Pyongtaek-Si, Kyongki-Do,  
-451-950-  
Pyongtaek Yosu Busan Daegu  
Phone +82 / 31 / 664-40 95  
Telefax +82 / 31 / 664-40 94  
Branch Offices: Ulsan

## Kuwait

Dan Trading & Contracting  
Co. W.L.L.  
P.O. Box 5092  
13051 Safat, Kuwait  
Phone +965 / 2 43 25 53  
Telefax +965 / 2 43 78 33

## Latvia

Filter SIA  
Aizkraukles 21  
10069 Riga  
Phone +00371 7801 921  
Telefax +00371 7550 224

## Libya

United Technical & Engineering  
Misanran St.  
P.O. Box 81276  
Tripoli G.S.P.L.A.J.  
Phone +218 21 4442 641  
Telefax +218 21 4776 152

## Lithuania

Dmitri Melnikow  
Balandzius 5-2  
LT-91188 Klaipeda  
Phone / Fax +370 46 31 29 49  
Mobile +370 69 82 14 27

## Malaysia

EagleBurgmann (Malaysia)  
Sdn. Bhd.  
No. 7, Lorong SS13, 6 B  
Off Jalan SS13/6  
Subang Jaya Industrial Estate  
47500 Petaling Jaya  
Phone +60 / 3 / 56 34 86 24  
Telefax +60 / 3 / 56 34 97 42

## Mexico

EagleBurgmann Mexico  
S.A. de C.V.  
Calzada de Guadalupe  
Num. 350-6, Col. El Cerrito  
C.P. 54720, Cuautitlan Izcalli,  
Estado de México, Mexico City  
Phone +52 / 55 / 58 72 53 93  
Telefax +52 / 55 / 58 72 64 93

## Morocco

Petro-Mat  
Angle Rue Michel de l'Hôpital  
et Rue Jules Cesar  
Casablanca 05  
Phone +212 / 240 / 87 99  
Telefax +212 / 240 / 19 39

## Netherlands

EagleBurgmann Netherlands B.V.  
Koningsschot 9  
NL-3905 PP Veenendaal  
Phone +31 / 318 / 54 20 00  
Telefax +31 / 318 / 54 15 35

## New Zealand

EagleBurgmann New Zealand Ltd.  
P.O. Box 34285, Birkenhead,  
3 Parity Place, Glenfield, Auckland  
Phone +64 / 9 / 4 43 57 72  
Telefax +64 / 9 / 4 41 27 66

## Nigeria

Sealing Engineering Services Ltd.  
82 St. Finbarr's College Road  
Akoka / Yaba, Lagos  
Phone +234 / 1 / 82 59 09  
Telefax +234 / 1 / 82 59 09

## Norway

EagleBurgmann Norway AS  
P.O. Box 143  
Industriveien 25 D  
N-2021 Skedsmokorset  
Phone +47 / 64 / 83 75 50  
Telefax +47 / 64 / 83 75 75

## Oman

Overseas Petroleum  
Equipment Co. L.L.C.  
P.O. Box 261, Hamriya  
Postal Code 131, Sultanate  
of Oman  
Phone +968 / 60 21 82  
Telefax +968 / 60 20 84

## Pakistan

Azif Asim Associates  
Suit #02, 1st Floor,  
Sameer plaza Civic Center, 3-C1  
Faisal Town  
54660 Lahore, Pakistan  
Phone +92 / 42 / 111 585  
Telefax +92 / 42 / 516 83 44

## Techno-Mech Pakistan

51-A/1, Rehmanpura,  
Ferozpur Road  
54660 Lahore, Pakistan  
Phone +92 / 42 / 757 5671  
Telefax +92 / 42 / 759 7373

## Peru

Corporación Gamma S.A.C.  
Av. La Marina 1321, San Miguel  
Lima - Peru  
Phone +51 / 12 / 63 76 70  
Telefax +51 / 12 / 63 02 86

## Philippines

Burgmann (Philippines) Inc.  
No. 9769 National Road, Maduya  
Carmona, Cavite  
Phone +63 / 49 / 8 39 06 55  
Telefax +63 / 49 / 8 39 06 54

## Poland

KE-Burgmann Polska  
Spółka z o.o.  
Al. Jerozolimskie 200  
PL-02-486 Warszawa  
Phone +48 22 535 16 00  
Telefax +48 22 535 16 48

## Portugal

EagleBurgmann Ibérica S.A.  
Avda. de Quitapesares, 40  
E-28670 Villaviciosa de Odón,  
Mdrid  
Phone +34-91-616 66 01  
Telefax +34-91-616 66 81

## Qatar

Jaidah Motors and Trading Co.  
P.O.Box 150  
Doha / Qatar / Arabian Gulf  
Phone +974 / 68 21 82  
Telefax +974 / 41 41 00

## Romania

EagleBurgmann RO S.R.L.  
Bd. Iuliu Maniu, Nr. 7  
Clujdea E, Parter, Hala 3, Sector  
RO 061072, Bucaresti  
Tel. +40 / 314 25 09 09  
Telefax +40 / 314 25 09 10

## Russia

EagleBurgmann OOO  
Ul. Zhelezodorozhnaya, 1, str. 45  
606524 Zavolzhye  
Gorodetsky district,  
Nizhny Novgorod region  
Phone +7 / 831 / 6 93 05 58  
Telefax +7 / 831 / 6 93 05 59

Moscow Representation  
Ul. Novotcheremushkinskaja 61  
RF-117418 Moskva  
Phone +7 / 095 / 7 97 20 14  
Telefax +7 / 095 / 7 97 20 78

## Saudi Arabia

Burgmann  
Saudi Arabia Limited  
PO box No. 3422,  
Dammam Port Road  
Dammam, Saudi Arabia  
Phone +96 / 63 / 8 59 91 19  
Telefax +96 / 63 / 8 59 92 29

Gas Arabian Services Est  
P.O.Box 3422  
Dammam 31471, King Saud Street  
Kingdom of Saudi Arabia  
Phone +96 / 63 / 8 35 15 00  
Telefax +96 / 63 / 8 32 28 22

## Singapore

EagleBurgmann Singapore Pte. Ltd.  
52 Serangoon North Avenue 4,  
#03-02 Ever Tech Building  
555853 Singapore  
Phone +65 / 64 81 34 39  
Telefax +65 / 64 81 39 34

EBI Asia Pacific Pte. Ltd.  
29 International Business Park,  
Acer Big, Tower B, #03-03  
609923 Singapore  
Phone+65 / 65 65 66 23  
Telefax +65 / 65 65 96 63

KE-Burgmann Singapore Pte. Ltd.  
Expansion Joints  
Blk 7 Pioneer Road North  
No. 01-51, Singapore 628459  
Phone +65 / 62 61 85 81  
Telefax +65 / 62 61 85 89

## Slovenia (CRO, BIH, MAC, YU)

Branch Office Slovenia  
Malci Beliceve 37  
SLO-1000 Ljubljana  
Phone +386 / 1 / 4 23 15 57  
Telefax +386 / 1 / 2 57 40 57  
Mobile +386 / 41 / 66 13 15

## Slowakian Republic

EagleBurgmann Czech s.r.o.  
Na Drahač 1364  
CZ-15600 Praha 5 Zbraslav  
Phone +420 / 2 / 57 92 05 05  
Telefax +420 / 2 / 57 92 05 08

Technosam s.r.o.  
Galvaniho 2/A  
SK-82104 Bratislava  
Phone +421 / 2 / 43 41 35 85  
Telefax +421 / 2 / 43 41 36 03

## South Africa

EagleBurgmann Seals  
South Africa (PTY) LTD.  
1 Brunton Circle  
Founders View South,  
Modderfontein  
Johannesburg 2065, Gauteng,  
R.S.A.  
Phone +27 / 11 / 4 57 90 00  
Telefax +27 / 11 / 6 09 16 06  
Postal address: P.O. Box 1210,  
Edenvalle 1610, R.S.A.  
Also responsible for: Namibia,  
Botswana, Swaziland, Zambia,  
Zimbabwe, Mozambique,  
Mauritius, Congo, Ethiopia,  
Uganda, Tanzania

## Spain

EagleBurgmann Ibérica S.A.  
Avda. de Quitapesares, 40  
E-28670 Villaviciosa de Odón,  
Madrid  
Phone +34-91-616 66 01  
Telefax +34-91-616 66 81

## Sweden

EagleBurgmann Sweden AB  
Svärmaregatan 3  
S-60361 Norrköping  
Phone +46 / 11 / 14 00 05  
Telefax +46 / 11 / 14 00 15

EagleBurgmann Sweden AB  
Göteborg Office  
Askims Verkstadsväg 4  
S-436 34 Askim, Göteborg  
Phone +46 / 31 / 58 68 50  
Telefax +46 / 31 / 58 14 66  
Postal address:  
Box 9101, 40093 Göteborg

## Switzerland

EagleBurgmann (Switzerland) AG  
Holzstrasse 21, CH-8181 Hori  
Phone +41 / 44 / 8 60 88 00  
Telefax +41 / 44 / 8 61 01 35

## Taiwan

EagleBurgmann Taiwan Co. Ltd.  
1F No. 7, Lane 144 Chi Lin Rd.  
Taipei  
Taiwan, R.O.C.  
Phone +886 -2- 2581 0040  
Telefax +886 -2- 2523 2793

## Thailand

EagleBurgmann (Thailand) Co. Ltd.  
Banga Tower C, Floor 18th  
40/14 Moo 12 Banga-Trad Rd.  
Km. 6.5 Bangkaew, Bangplee  
Samutprakarn 10540  
Phone +66 / 2 / 7 51 96 21  
Telefax +66 / 2 / 7 51 96 28

## Trinidad

Eswil Equipment & Supply  
(W.I.) Ltd  
10 - 16 Lady Hailes Avenue  
San Fernando, Trinidad, W. I.  
P.O. Box 3565, La Romaine  
Trinidad, W. I.  
Phone +1 / 868 / 6 57 89 38  
Telefax +1 / 868 / 6 52 90 02

## Tunisia