

Carbon floating ring seals

Seal rings



WD-Series – Split housing



WKA-Series – Chamber seal



Shaft sleeves



Contents

The company	3
Product overview and typical fields of application	4
Espey™ WKA3 for standard fans	5
Espey™ WD200 for fans and blowers, steam turbines, vapour compressors, centrifuges	6
Espey™ WD200 – product variants (extract) and dimension table	7
Espey™ WDK-BHS as bulkhead seal	8
Espey™ WDK-BHS – dimension table	9
Espey™ WDKS-Eco for simple applications, small fans and blowers, bearings	10
Espey™ WDKS-Eco – product variants (extract) and dimension table	11
Espey™ WD500 for blowers, mills, dryers, centrifuges, gearbox sealing	12
Espey™ WD500 – product variants (extract) and dimension table	13
Espey™ WD200/500 for fans and blowers, centrifuges, steam turbines, cantilever pumps	14
Espey™ WD200/500 – product variants (extract) and dimension table	15
Espey™ WDMS500 for agitators	16
Espey™ WDMS500 – dimension table	17
Espey™ WKA300 for fans, bearings in low pressure applications	18
Espey™ WKA300 – product variants (extract) and dimension table	19
Espey™ WKA250ND for turbo compressors in low pressure applications	20
Espey™ WKA250ND – dimension table	21
Espey™ WKA400HD for turbo compressors, steam turbines in high pressure applications	22
Espey™ WKA400HD – dimension table	23
Espey™ WKA802HD für steam turbines, turbo compressors, compressors in high pressure applications	24
Espey™ WKA802HD – dimension table	25
Espey™ WKA1100HP for turbo compressors, compressors in high pressure applications	26
Espey™ WKA1100HP – dimension table	27
Espey™ WDB200 shaft sleeves	28
Espey™ WDB200 – product variants (extract) and dimension table	29
Application examples carbon floating ring seals	30
Quality and certificates	31

The company



Customized sealing systems

EagleBurgmann Espey designs and manufactures seals and sealing systems for use in the oil and gas, chemical and petrochemical sectors, in power plant engineering, shipbuilding and in the industry in general.

Our seals offer reliable solutions for sealing a wide range of gases, gaseous mixtures, powders and vapour in machines and plants such as turbines, fans, compressors, centrifuges and mills. Among our customers are OEM's, operators and engineering companies from around the world.

In close consultation with our customers, we design seals and systems customized to suit individual applications and installations in a wide range of situations.

EagleBurgmann Espey innovations are renowned for their added value. Wherever machines and systems require sealing, our products make a major contribution towards boosting performance, durability and efficiency.

Our professional advice and suggested solutions, underpinned by our versatile production facilities, aim to optimize the availability and economic potential of your plant. EagleBurgmann Espey has set itself the goal of significantly shortening delivery times and reliably increasing on-schedule delivery. To achieve these aims, our manufacturing facilities are fitted with the latest production monitoring systems.



EagleBurgmann Espey GmbH

The company was founded by Gustav Espey in Berlin 1888 as a factory for metal stuffing box packings. With the onset of industrialization, the company moved to the up-and-coming Ruhr region in 1927. The company has been located on the Moers-Genend industrial estate since 2005 and currently employs more than 70 staffs.

Today the company belongs to the EagleBurgmann Group. EagleBurgmann is an independent business group within the Freudenberg corporation; it manufactures, distributes mechanical seals, packings and static seals, as well as special products for a range of applications and branches of industry, and thus is one of the leading global companies in this field.

Freudenberg is a family-owned global corporation. With its 14 business groups, the firm is active in various sectors and markets.

Creativity, diversity and innovation are the cornerstones of its philosophy. Reliability and responsible conduct characterize the company's 160-year history. Freudenberg focuses on partnership with its customers, on the long-term perspective, not to mention on financial stability and the excellence of its approx. 32,000 employees in 55 countries around the globe.

Product overview and fields of application

Series	Standard shaft diameter	Operating pressure	Temperature	Sliding velocity	2-parts housing	Chamber design	Seal ring design			Port variants		
							1-piece	multi part	S	A	F	
WKA3	28 ... 80 mm (1.1 ... 3.15")	≤ 1,075 bar (16 PSI)	≤ 200 °C (392 °F)	≤ 40 m/s (131 ft/s)			x	x				
WD200	WDS	45 ... 340 mm (1.77 ... 13.39")	≤ 20 bar (290 PSI)	≤ 800 °C (1,472 °F)	≤ 150 m/s (492 ft/s)	x			x	x		
	WDA	45 ... 340 mm (1.77 ... 13.39")	≤ 20 bar (290 PSI)	≤ 800 °C (1,472 °F)	≤ 150 m/s (492 ft/s)	x			x		x	
	WDSA	45 ... 340 mm (1.77 ... 13.39")	≤ 20 bar (290 PSI)	≤ 800 °C (1,472 °F)	≤ 150 m/s (492 ft/s)	x			x	x	x	x
	WDK	45 ... 340 mm (1.77 ... 13.39")	≤ 20 bar (290 PSI)	≤ 800 °C (1,472 °F)	≤ 150 m/s (492 ft/s)	x			x			x
	WDKF	45 ... 340 mm (1.77 ... 13.39")	≤ 20 bar (290 PSI)	≤ 800 °C (1,472 °F)	≤ 150 m/s (492 ft/s)	x			x			x
	WDKS	45 ... 340 mm (1.77 ... 13.39")	≤ 20 bar (290 PSI)	≤ 800 °C (1,472 °F)	≤ 150 m/s (492 ft/s)	x			x	x		
WDKSF	45 ... 340 mm (1.77 ... 13.39")	≤ 20 bar (290 PSI)	≤ 800 °C (1,472 °F)	≤ 150 m/s (492 ft/s)	x			x	x		x	
WDK-BHS	40 ... 800 mm (1.57 ... 31.5")	≤ 3 bar (44 PSI)	≤ 225 °C (437 °F)	≤ 40 m/s (131 ft/s)	x			x	x			
WDKS-Eco	45 ... 160 mm (1.77 ... 6.3")	≤ 1.5 bar (22 PSI)	≤ 500 °C (932 °F)	≤ 150 m/s (492 ft/s)	x			x	x			
	WDS	45 ... 340 mm (1.77 ... 13.39")	≤ 3 bar (44 PSI)	≤ 700 °C (1,292 °F)	≤ 40 m/s (131 ft/s)	x			x	x		
WD500	WDA	45 ... 340 mm (1.77 ... 13.39")	≤ 3 bar (44 PSI)	≤ 700 °C (1,292 °F)	≤ 40 m/s (131 ft/s)	x			x		x	
	WDK	45 ... 340 mm (1.77 ... 13.39")	≤ 3 bar (44 PSI)	≤ 700 °C (1,292 °F)	≤ 40 m/s (131 ft/s)	x			x			
WD200/500	1S1	45 ... 340 mm (1.77 ... 13.39")	≤ 3 bar (44 PSI)	≤ 500 °C (932 °F)	≤ 40 m/s (131 ft/s)	x			x	x		
	1S2	45 ... 340 mm (1.77 ... 13.39")	≤ 3 bar (44 PSI)	≤ 500 °C (932 °F)	≤ 40 m/s (131 ft/s)	x			x	x		
	1S3	45 ... 340 mm (1.77 ... 13.39")	≤ 3 bar (44 PSI)	≤ 500 °C (932 °F)	≤ 40 m/s (131 ft/s)	x			x	x		
	1S2A1	45 ... 340 mm (1.77 ... 13.39")	≤ 3 bar (44 PSI)	≤ 500 °C (932 °F)	≤ 40 m/s (131 ft/s)	x			x	x	x	
WDMS500	40 ... 220 mm (1.57 ... 8.66")	≤ 6 bar (87 PSI)	≤ 500 °C (932 °F)	≤ 5 m/s (16 ft/s)	x			x	x	o		
WKA300	20 ... 300 mm (0.79 ... 11.81")	≤ 0.5 bar (7 PSI)	≤ 500 °C (932 °F)	≤ 150 m/s (492 ft/s)		x		x	o	o	o	
WKA250ND	20 ... 300 mm (0.79 ... 11.81")	≤ 15 bar (218 PSI)	≤ 500 °C (932 °F)	≤ 240 m/s (787 ft/s)		x		x	o	o		
WKA400HD	20 ... 300 mm (0.79 ... 11.81")	≤ 75 bar (1,088 PSI)	≤ 500 °C (932 °F)	≤ 240 m/s (787 ft/s)		x		x	o	o		
WKA802HD	20 ... 200 mm (0.79 ... 7.87")	≤ 140 bar (2,030 PSI)	≤ 225 °C (437 °F)	≤ 240 m/s (787 ft/s)		x	x		o	o		
WKA1100HP	20 ... 200 mm (0.79 ... 7.87")	≤ 250 bar (3,626 PSI)	≤ 225 °C (437 °F)	≤ 240 m/s (787 ft/s)		x	x		o	o		

S= buffer gas port, A = suction, F = grease barrier, o = possible depending on design

Series	Fan/Blower	Compressor	Centrifuge	Turbine	Mixer	Gear/Motor	Dryer	Bulkhead	Mill
WKA3	x								
WD200	x			x		x		x	
WDK-BHS								x	
WDKS-Eco	x								
WD500			x			x	x		x
WDMS500					x				
WD200/500			x		x		x		x
WKA300	x								
WKA250ND		x		x					
WKA400HD		x		x					
WKA802HD		x		x					
WKA1100HP		x							

Important note

All the technical specifications are based on extensive tests and our many years of experience. However, the diversity of possible applications means that they can serve as guide values only. It should be noted that the extremal values of each operating parameter cannot be applied at the same time because of their interaction. Furthermore, the operating range of each specific product depends on the respective shaft diameter, materials used, mode of operation and on the medium to be sealed. A guarantee can only be given in the individual case if the exact conditions of application are known and these are confirmed in a special agreement. When critical conditions of operation are involved, we recommend consulting with our specialist engineers. Subject to change.

Espey™ WKA3

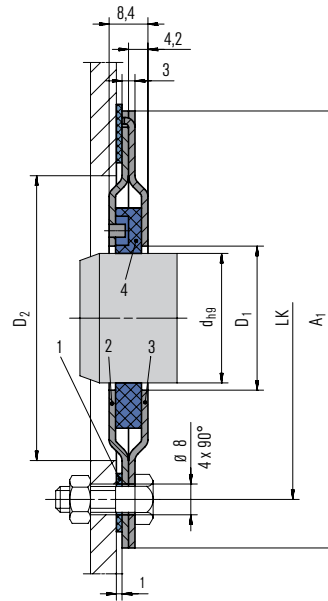

Features

- Cartridge seal
- Standardized dimensions
- Short axial installation length (8.4 mm)
- Dry running
- Seal ring bears radial shaft movements
- Compensates axial shaft movements
- No sealing components mounted on the shaft and hence no additional shaft vibrations
- Seal rings running contact-free – sliding faces and machine consume no additional power
- One-piece seal ring (initial delivery)

Advantages

- Easy installation
- High reliability
- Maintainability
- Long-term operation time
- Alternative to radial shaft seal ring

Item Description

- | | |
|---|--------------|
| 1 | Flat seal |
| 2 | Housing half |
| 3 | Housing half |
| 4 | Seal ring |

Operating range (see note on page 4)

Shaft diameter: $d = 28 \dots 80 \text{ mm}$ (1.10" ... 3.15")
 Operating pressure: $p = 1.075 \text{ bar}$ (16 PSI) abs.
 Operating temperature: $t = \text{max. } +200 \text{ }^\circ\text{C}$ (392 °F)
 Sliding velocity: $v_g = \text{max. } 40 \text{ m/s}$ (131 ft/s)
 Radial play: $2.0 \dots 4.0 \text{ mm}$ (0.08" ... 0.16")
 Axial movement: theoretically unlimited

Materials

Seal ring: PTFE compound
 Housing: 1.4301
 Tension spring: 1.4571 (replacement)

Standards and approvals

- FDA

Recommended applications

- Chemical industry
- Food processing industry
- Machinery and plant building
- Pulp and paper industry
- Metal production and processing
- Small and medium-sized fans/blowers
- Air regulating devices
- Bearing seals
- Clean gases*

* Not applicable for toxic, solids containing gases and exhaust gas and fluid

Dimensions in mm

d_{h9}	D_1	D_2	A_1	LK	RB	RC
28	36	70	100	90	35	30
30	36	70	100	90	35	30
32	36	70	100	90	35	30
38	46	80	110	100	40	35
40	46	80	110	100	40	35
42	46	80	110	100	40	35
50	56	94	130	120	45	40
60	66	104	140	130	50	45
70	76	114	150	140	55	50
80	86	124	160	150	60	55

Espey™ WD200

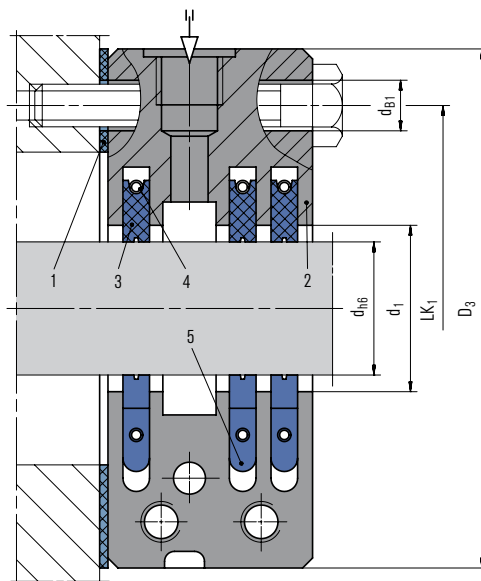

Features

- Split housing design
- Multi-part seal rings, radially cut
- Very small operation gap – low leakage
- Dry running
- Self-adjusting seal rings
- Seal rings bear radial shaft movements
- Compensates axial shaft movements
- No sealing components mounted on the shaft and hence no additional shaft vibrations
- Seal rings running contact-free – sliding faces and machine consume no additional power

Advantages

- Easy installation by split housing design (shaft removal not required)
- Long-term operation time
- Maintainability
- Segmented seal rings for easy replacement



Seal rings Espey™ WD200 (3-part, radial cut) – carbon / PTFE compound

Item Description

- | Item | Description |
|------|------------------|
| 1 | Flat seal |
| 2 | Housing, 2-piece |
| 3 | Seal ring |
| 4 | Tension spring |
| 5 | Detent |

Operating range (see note on page 4)

Shaft diameter: $d = 40 \dots 340 \text{ mm}$ (1.57" ... 13.39")
 Operating pressure: $p = \text{vacuum} \dots 20 \text{ bar}$ (290 PSI) abs.
 Operating temperature: $t = -120 \text{ °C} \dots +800 \text{ °C}$
 (-184 °F ... +1,472 °F) for carbon, max. 225 °C (437 °F) for PTFE compound
 Sliding velocity: $v_g = \text{max. } 150 \text{ m/s}$ (492 ft/s) for carbon, max. 40 m/s (131 ft/s) for PTFE compound
 Radial play: 2.5 ... 5.0 mm (0.1" ... 0.2")
 Axial movement: theoretically unlimited
 Recommended wear guard: > 300 HB (low pressure), > 58 HRC (high pressure)

Materials

Seal ring: Carbon, PTFE compound
 Housing: 1.4021, 1.4571, Hastelloy™, Titanium, Inconel™, others
 Tension spring/detent: 1.4571, Hastelloy™, Titanium, Inconel™

Standards and approvals

- FDA

Recommended applications

- Chemical industry
- Waste incineration and removal industry
- Power plant technology
- Petrochemical industry
- Food processing industry
- Metal production and processing
- Gases
- Fumes and exhaust, solids containing, flammable (ATEX), acid containing and toxic gases
- (Solids containing) steams/liquid mist
- Oil mist/penetrating oil
- Water
- Medium-sized and large fans/blowers
- Bearing seals (gear box, motors)
- Steam turbines
- Mixers, agitators, mills, dryers



Espey™ WD200, installed on a fan shaft
 Photo: Illinois Blower, Inc

Espey™ WD200

Product variants

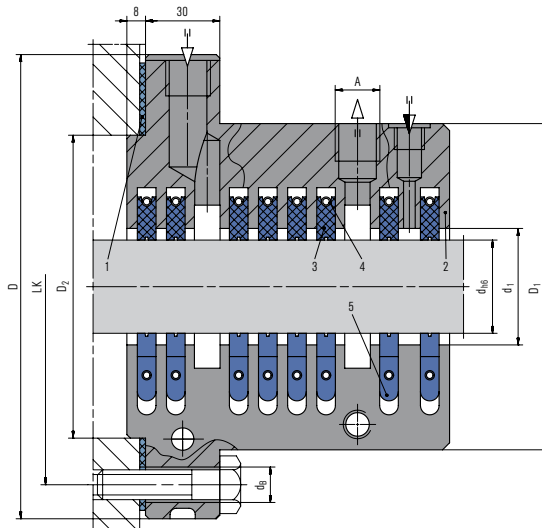
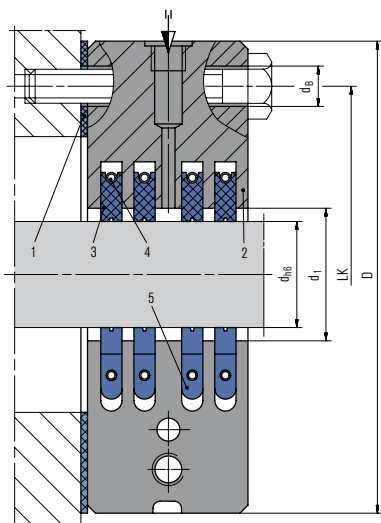

Espey™ WD200-WDK with short design and grease barrier port – type WDKF in addition with reduced outside housing diameter (for clean media, not for solids containing gases).

Espey™ WD200-WDSA with barrier gas, suction and grease barrier port (for e. g. toxic and solids containing gases with condensate formation as well as Atex applications).

For toxic and solids containing gases as well as Atex applications type shaft seal

Espey™ WD200-WDKS with short design, reduced housing outside diameter and barrier gas port is used.

Dimensions in mm

For all types			For types WDK, WDS, WDA, WDSA					For types WDKS, WDKF			
$d_{h6}^{1)}$	$d_{1, ND}^{1)}$	$d_{1, HD}^{1)}$	$D^{2)}$	$D_1^{2)}$	$D_2^{2)}$	$LK^{2)}$	$A^{2)}$	$d_5^{2)}$	$D_3^{3)}$	$LK_1^{3)}$	$d_{B1}^{3)}$
45	50	48	210	140	115	175	G1/2	15	165	135	15
50	58	54	220	150	125	185	G1/2	15	170	140	15
60	68	64	230	160	135	195	G3/4	15	180	150	15
70	78	74	240	170	145	205	G3/4	15	190	160	15
80	90	84	260	180	155	220	G3/4	15	200	170	15
90	100	94	270	190	165	230	G1	15	210	180	15
100	110	104	280	200	175	240	G1	15	220	190	15
110	120	114	290	210	185	250	G1	15	230	200	15
120	130	124	300	220	195	260	G1	15	240	210	15
130	140	134	310	230	205	270	G1	15	250	220	15
140	150	144	320	240	215	280	G1	15	260	230	15
150	160	154	330	250	225	290	G1	15	270	240	15
160	170	164	340	260	235	300	G1	19	280	250	15
170	180	174	350	270	245	310	G1	19	290	260	15
180	190	184	360	280	255	320	G1	19	300	270	15
190	200	194	370	290	265	330	G1	19	310	280	15
200	210	204	420	310	275	365	G1	15	320	290	15
220	230	224	440	330	295	385	G1	15	340	310	15
240	250	244	450	350	315	405	G1	19	360	330	15
260	270	264	460	370	335	425	G1	19	380	350	15
280	290	284	500	390	355	445	G1	19	400	370	15
300	310	304	520	410	375	465	G1	19	420	390	15
320	330	324	540	430	395	485	G1	19	440	410	15
340	350	344	560	450	415	505	G1	19	460	430	15

1) For all types

2) For types WDK, WDS, WDA, WDSA

3) For types WDKS, WDKF

ND= Low pressure, HD= High pressure

Special sizes on request

Espey™ WDK-BHS

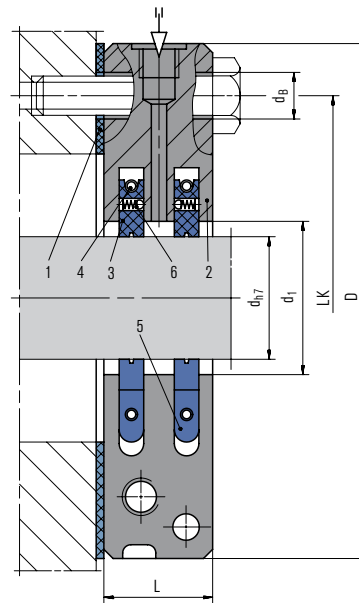
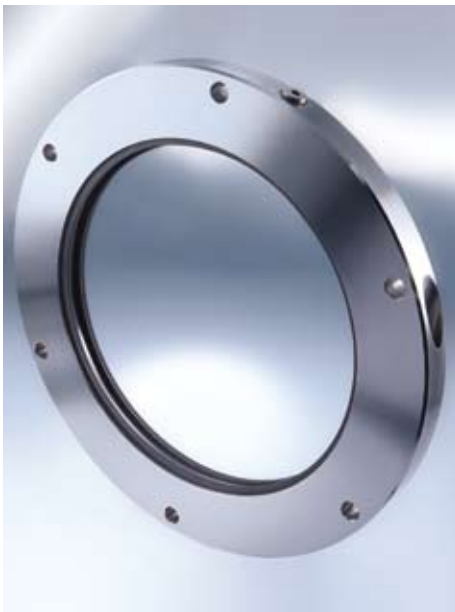

Features

- Multi-part seal rings, radially cut
- Split housing design
- Short axial installation length (max. 36 mm)
- Very small operation gap
- Dry running
- Self-adjusting seal rings
- Seal rings bear radial shaft movements
- Compensates axial shaft movements
- Seals on both sides of the shaft
- Resistant to sea water
- No sealing components mounted on the shaft and hence no additional shaft vibrations
- Seal rings running contact-free – sliding faces and machine consume no additional power

Advantages

- Easy installation by split housing design (shaft removal not required)
- Long-term operation time
- Maintainability
- Segmented seal rings for easy replacement

Item Description

- | | |
|---|------------------|
| 1 | Flat seal |
| 2 | Housing, 2-piece |
| 3 | Seal ring |
| 4 | Tension spring |
| 5 | Detent |
| 6 | Spring |

Operating range (see note on page 4)

Shaft diameter: $d = 40 \dots 800 \text{ mm}$ (1.57" ... 31.5")
 Operating pressure: $p = \text{vacuum} \dots 1.5 \text{ bar}$ (22 PSI) abs.
 Operating temperature: $t = \text{max. } 225 \text{ }^\circ\text{C}$ (437 °F)
 Sliding velocity: $v_g = \text{max. } 40 \text{ m/s}$ (131 ft/s)
 Radial play: $2.5 \dots 5.0 \text{ mm}$ (0.1" ... 0.2") (depending on shaft diameter)
 Axial movement: theoretically unlimited
 Angular deviation: $\pm 1^\circ \dots \pm 2^\circ$ (central installation, depending on shaft diameter)
 Recommended wear guard: $> 150 \text{ HB}$

Materials

Seal ring: PTFE compound
 Housing: 1.4021, AlMg₃, others
 Tension spring/detent: 1.4571
 Plug: 1.4571/copper

Standards and approvals

- ISO 9001
- American Bureau of Shipping (ABS), Bureau Veritas, Lloyd's Register EMEA, Det Norske Veritas, Russian Maritime Register of Shippings, Germanischer Lloyd

Recommended applications

- Shipbuilding
- Sea water, water
- Drive shafts in ships, bulkheads

Espey™ WDK-BHS

Dimensions in mm

d_{h7}	d_1	D	L	LK	n x α	d_g
40	45	160	30	130	4 x 90°	15
45	50	165	30	135	4 x 90°	15
50	58	170	30	140	4 x 90°	15
60	68	180	30	150	4 x 90°	15
70	78	190	30	160	4 x 90°	15
80	90	200	30	170	4 x 90°	15
90	100	210	30	180	4 x 90°	15
100	110	220	30	190	4 x 90°	15
110	120	230	30	200	4 x 90°	15
120	130	240	30	210	4 x 90°	15
130	140	250	30	220	4 x 90°	15
140	150	260	30	230	4 x 90°	15
150	160	270	30	240	4 x 90°	15
160	170	280	30	250	4 x 90°	15
170	180	290	30	260	6 x 60°	15
180	190	300	30	270	6 x 60°	15
190	200	310	30	280	6 x 60°	15
200	210	320	30	290	6 x 60°	15
220	230	340	30	310	6 x 60°	15
240	250	360	30	330	6 x 60°	15
260	270	380	30	350	6 x 60°	15
280	290	400	30	370	6 x 60°	15
300	310	420	30	390	6 x 60°	15
320	330	440	30	410	6 x 60°	15
340	350	460	30	430	6 x 60°	15
350	360	470	30	440	8 x 45°	15
400	410	520	30	490	8 x 45°	15
450	460	570	30	540	8 x 45°	15
500	510	620	30	590	8 x 45°	15
550	560	670	30	640	8 x 45°	15
600	610	720	30	690	8 x 45°	15
650	660	770	36	740	12 x 45°	15
700	710	820	36	790	12 x 45°	19
750	760	870	36	840	12 x 45°	19
800	810	920	36	890	12 x 45°	19

Special sizes on request



Espey™ WDKS-Eco

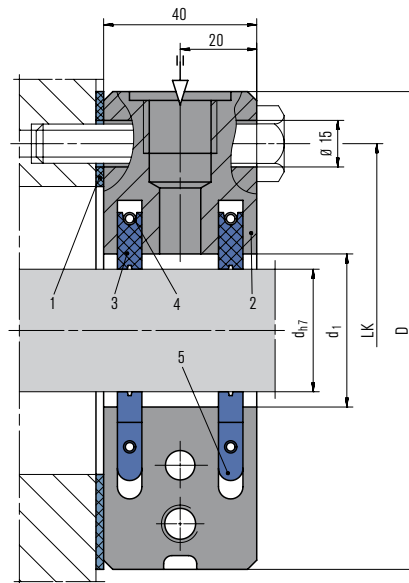
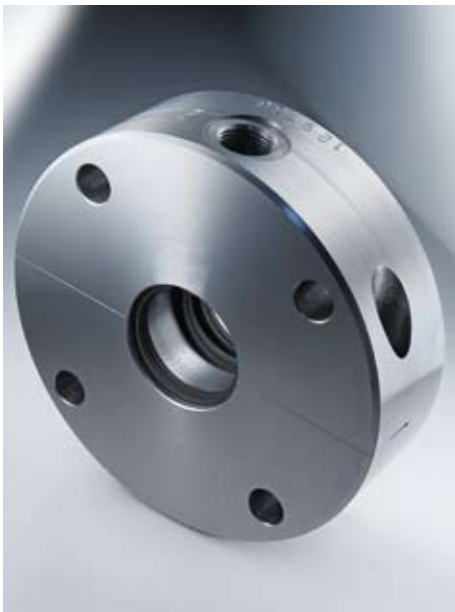

Features

- Multi-part seal rings, radially cut
- Split housing design
- Very small operation gap – low leakage
- Dry running
- Self-adjusting seal rings
- Seal rings bear radial shaft movements
- No sealing components mounted on the shaft and hence no additional shaft vibrations
- Seal rings running contact-free – sliding faces and machine consume no additional power

Advantages

- Easy installation by split housing design (shaft removal not required)
- Long-term operation time
- Maintainability
- Segmented seal rings for easy replacement

Item Description

- | Item | Description |
|------|------------------|
| 1 | Flat seal |
| 2 | Housing, 2-piece |
| 3 | Seal ring |
| 4 | Tension spring |
| 5 | Detent |

Operating range (see note on page 4)

Shaft diameter: $d = 45 \dots 160 \text{ mm}$ (1.77" ... 6.3")
 Operating pressure: $p = \text{vacuum} \dots 1.5 \text{ bar}$ (22 PSI) abs.
 Operating temperature: $t = -120 \text{ }^\circ\text{C} \dots +500 \text{ }^\circ\text{C}$
 (-184 °F ... +932 °F) for carbon,
 max. 225 °C (437 °F) for PTFE compound,
 max. 300 °C (572 °F) with grease
 Sliding velocity: $v_g = \text{max. } 150 \text{ m/s}$ (492 ft/s) for carbon, max. 40 m/s (131 ft/s) for PTFE compound
 Radial play: 2.5 ... 5.0 mm (0.1" ... 0.2")
 Axial movement: theoretically unlimited
 Recommended wear guard: > 300 HB (low pressure)

Materials

Seal ring: Carbon, PTFE compound
 Housing: 1.4021, 1.4571, others
 Tension spring/detent: 1.4571

Standards and approvals

- FDA

Recommended applications

- Chemical industry
- Metal production and processing
- Pulp and paper industry
- Food processing industry
- Power plant technology
- (Solids containing) gases
- (Solids containing) steams/liquid mist
- Oil mist/penetrating oil
- Water
- Small and medium-sized fans/blowers
- Bearing seals (gear box, motors)
- Mixers, agitators, mills, dryers



Fan
 Photo: Illinois Blower, Inc..

Espey™ WDKS-Eco

Product variants

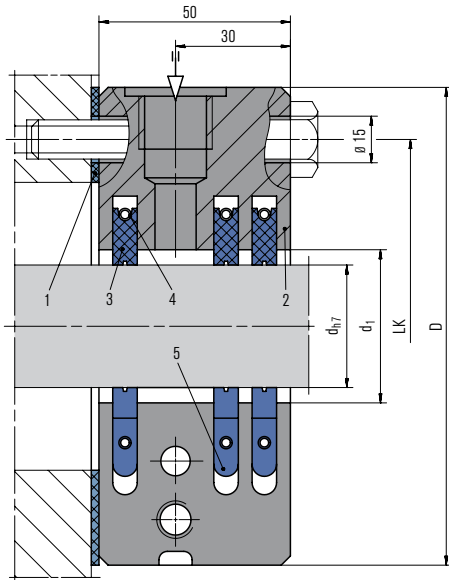

Espey™ WDKS-Eco with 3 seal rings

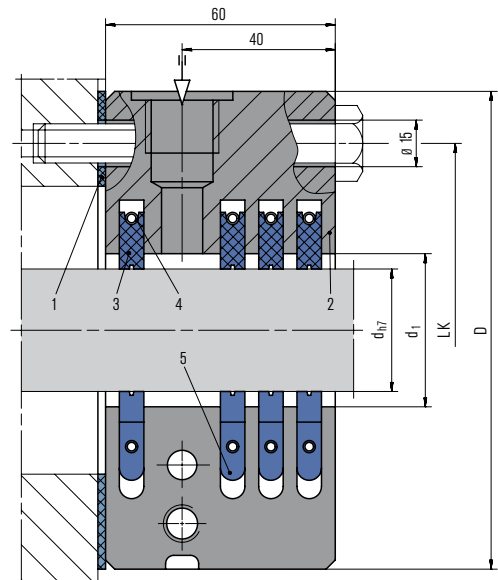

Espey™ WDKS-Eco with 4 seal rings

Dimensions in mm

d_{h7}	d_1	D	LK
45	50	165	135
50	58	170	140
60	68	180	150
70	78	190	160
80	90	200	170
90	100	210	180
100	110	220	190
110	120	230	200
120	130	240	210
130	140	250	220
140	150	260	230
150	160	270	240
160	170	280	250

Special sizes on request



Espey™ WDKS-Eco, installed on a fan shaft
Photo by courtesy of Aurubis AG



Continuous kilns' fan drives for the heat treatment of metal strips
Photo by courtesy of Aurubis AG

Espey™ WD500

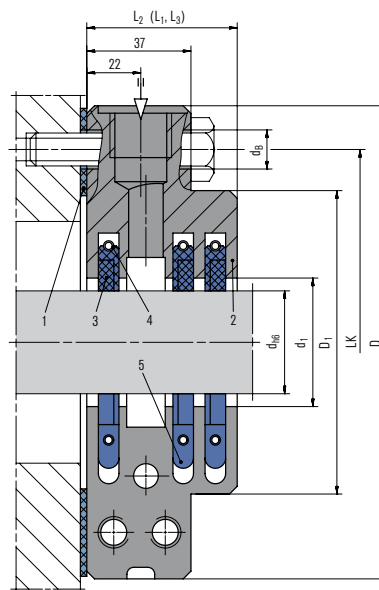

Features

- Multi-part seal rings, overlapped mortised with gas tight joints (adjusting)
- Split housing design
- Lowest possible operation gap – lowest leakage
- Dry-running
- Self-adjusting seal rings
- Seal rings bear radial shaft movements
- Compensates axial shaft movements
- Short axial installation length
- No sealing components mounted on the shaft and hence no additional shaft vibrations

Advantages

- Easy installation by split housing design (shaft removal not required)
- Long-term operation time
- Maintainability
- Segmented seal rings for easy replacement

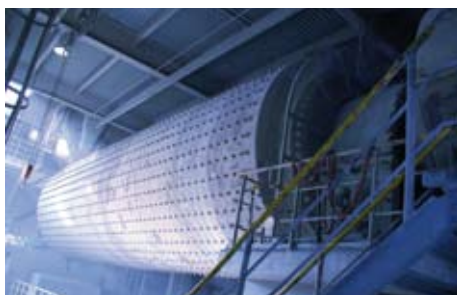

Ball mill for the cement production

Item Description

- | Item | Description |
|------|------------------|
| 1 | Flat seal |
| 2 | Housing, 2-piece |
| 3 | Seal ring |
| 4 | Tension spring |
| 5 | Detent |

Operating range (see note on page 4)

Shaft diameter: $d = 45 \dots 340 \text{ mm}$ (1.77" ... 13.89")
 Operating pressure: $p = \text{vacuum} \dots 3 \text{ bar}$ (44 PSI) abs. (depends on peripheral velocity)
 Operating temperature: $t = -120 \text{ °C} \dots +500 \text{ °C}$ (-184 °F ... +932 °F) for carbon [700 °C (1,292 °F) for blast furnaces], -120 °C ... +150 °C (-184 °F ... +302 °F) for PTFE compound
 Sliding velocity: $v_g = \text{max. } 40 \text{ m/s}$ (131 ft/s)
 Radial play: 2.5 ... 5.0 mm (0.1" ... 0.2")
 Axial movement: theoretically unlimited
 Recommended wear guard: > 58 HRC

Materials

Seal ring: Carbon, PTFE compound
 Housing: 1.4021, 1.4571, Hastelloy™, Titanium, Inconel™, others
 Tension spring/detent: 1.4571, Hastelloy™, Titanium, Inconel™

Standards and approvals

- FDA

Recommended applications

- Chemical industry
- Waste incineration and removal industry
- Pulp and paper industry
- Lime, cement and gypsum industry
- Mining industry
- Water and waste water technology
- Gases
- Fumes and exhaust, solids containing, flammable (ATEX), acid containing and toxic gases
- (Solids containing) steams/liquid mist
- Oil mist/penetrating oil
- Water
- Medium-sized and large fans/blowers
- Bearing seals (gear box, motors)
- Steam turbines
- Mixers, agitators, dryers
- Mills (ball, hammer, beater mills)
- Centrifuges

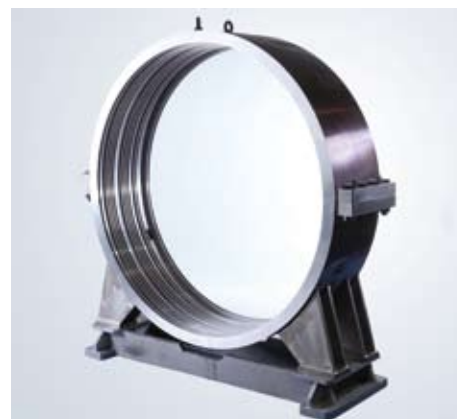

Espey™ WD500 Special with support base

Espey™ WD500

Product variants

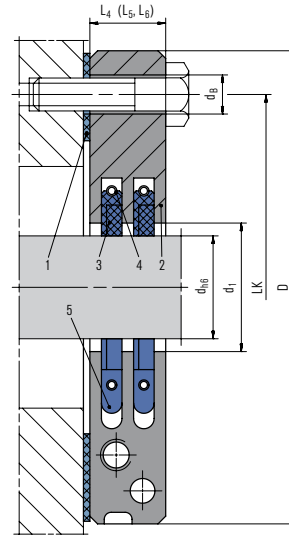
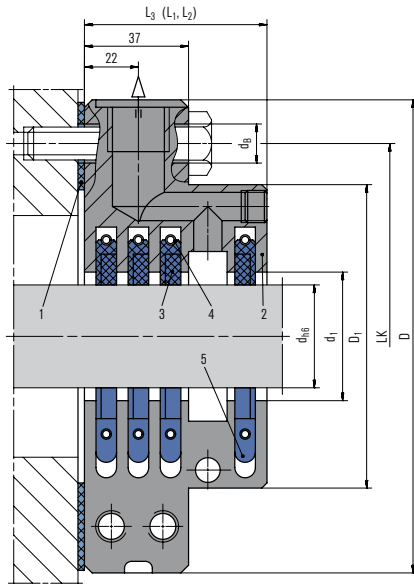

Espey™ WD 500-WDA for applications involving condensate formation to enable directed throwing off to the outside of the housing (not for solids containing gases).

Espey™ WD500-WDK with short design (for clean media, not for solids containing gases).

Dimensions in mm

For all types						For types WDS, WDA			For type WDK		
$d_{h6}^{1)}$	$d_1^{1)}$	$D^{1)}$	$D_1^{1)}$	$d_b^{1)}$	$L_K^{1)}$	$L_1^{2)}$	$L_2^{2)}$	$L_3^{2)}$	$L_4^{2)}$	$L_5^{3)}$	$L_6^{3)}$
45	50	210	140	15	175	47	59	71	28	40	52
50	58	220	150	15	185	47	59	71	28	40	52
60	68	230	160	15	195	47	59	71	28	40	52
70	78	240	170	15	205	47	59	71	28	40	52
80	90	260	180	15	220	47	59	71	28	40	52
90	100	270	190	15	230	47	59	71	28	40	52
100	110	280	200	15	240	51	65	79	32	46	60
110	120	290	210	15	250	51	65	79	32	46	60
120	130	300	220	15	260	51	65	79	32	46	60
130	140	310	230	15	270	51	65	79	32	46	60
140	150	320	240	15	280	51	65	79	32	46	60
150	160	330	250	15	290	51	65	79	32	46	60
160	170	340	260	19	300	51	65	79	32	46	60
170	180	350	270	19	310	51	65	79	32	46	60
180	190	360	280	19	320	51	65	79	32	46	60
190	200	370	290	19	330	51	65	79	32	46	60
200	210	420	310	15	365	55	71	87	36	52	68
220	230	440	330	15	385	55	71	87	36	52	68
240	250	460	350	15	405	55	71	87	36	52	68
260	270	480	370	19	425	55	71	87	36	52	68
280	290	500	390	19	445	55	71	87	36	52	68
300	310	520	410	19	465	55	71	87	36	52	68
320	330	540	430	19	485	55	71	87	36	52	68
340	350	560	450	19	505	55	71	87	36	52	68

1) For all types

2) For types WDS, WDA

3) For type WDK

Special sizes on request

Special dimensions for e. g. blast furnaces, mills and dryers up to $d = 4,000$ mm

Length L depending on number of seal rings and type

Espey™ WD200/500

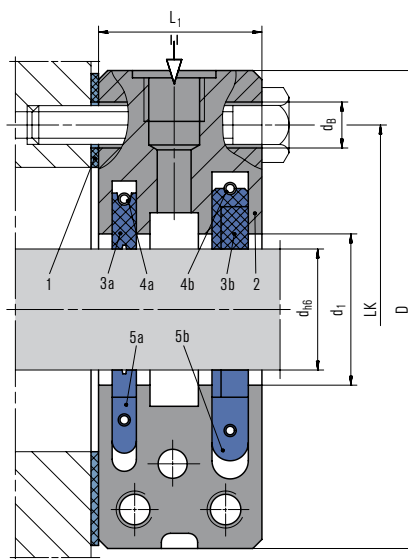

Features

- Multi-part seal rings, radially cut on process side, overlapped mortised with gas tight joints on atmosphere side (adjusting)
- Split housing design
- Lowest possible operation gap – lowest leakage
- Dry-running
- Self-adjusting seal rings
- Seal rings bear radial shaft movements
- Compensates axial shaft movements
- Short axial installation length
- No sealing components mounted on the shaft and hence no additional shaft vibrations

Advantages

- Easy installation by split housing design (shaft removal not required)
- Long-term operation time
- Maintainability
- Segmented seal rings for easy replacement



Espey™ WD200/500: upper housing half dismantled

Item Description

- | Item | Description |
|------|----------------------|
| 1 | Flat seal |
| 2 | Housing, 2-piece |
| 3a | Seal ring WD200 |
| 3b | Seal ring WD500 |
| 4a | Tension spring WD200 |
| 4b | Tension spring WD500 |
| 5a | Detent WD200 |
| 5b | Detent WD500 |

Operating range (see note on page 4)

Shaft diameter: $d = 45 \dots 340 \text{ mm}$ (1.77" ... 13.89")
 Operating pressure: $p = \text{vacuum} \dots 3 \text{ bar}$ (44 PSI) abs. (depends on peripheral velocity)
 Operating temperature: $t = -120 \text{ °C} \dots +500 \text{ °C}$ (-184 °F ... +932 °F) for carbon, $-120 \text{ °C} \dots +150 \text{ °C}$ (-184 °F ... +302 °F) for PTFE compound
 Sliding velocity: $v_g = \text{max. } 40 \text{ m/s}$ (131 ft/s)
 Radial play: $2.5 \dots 5.0 \text{ mm}$ (0.1" ... 0.2")
 Axial movement: theoretically unlimited
 Recommended wear guard: $> 58 \text{ HRC}$

Materials

Seal ring: Carbon, PTFE compound
 Housing: 1.4021, 1.4571, Hastelloy™, Titanium, Inconel™, others
 Tension spring/detent: 1.4571, Hastelloy™, Titanium, Inconel™

Standards and approvals

- FDA

Recommended applications

- Chemical industry
- Waste incineration and removal industry
- Metal production and processing
- Pulp and paper industry
- Lime, cement and gypsum industry
- Food processing industry
- Power plant technology
- Machinery and plant building
- Gases
- Fumes and exhaust, solids containing, flammable (ATEX), acid containing and toxic gases
- (Solids containing) steams/liquid mist
- Oil mist/penetrating oil
- Water
- Medium-sized and large fans/blowers
- Bearing seals (gear box, motors)
- Steam turbines
- Mixers, agitators, dryers
- Mills (ball, hammer, beater mills)
- Centrifuges
- Cantilever pumps



Centrifuge
 Photo: Thomas Broadbent and Sons

Espey™ WD200/500

Product variants

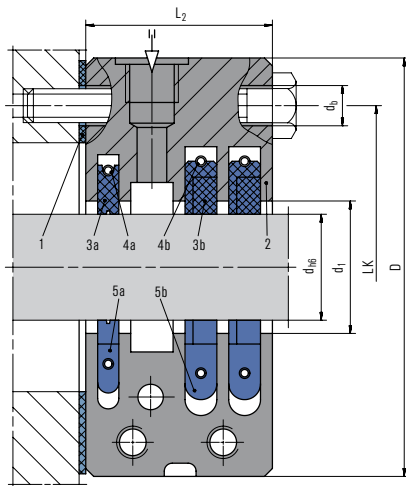

Espey™ WD200/500-WD1S2 with barrier gas port. The arrangement guarantees a focused barrier gas flow to the process side and keeps gases, solids and mists off the sealing area. In addition the leakage to the outside is reduced.

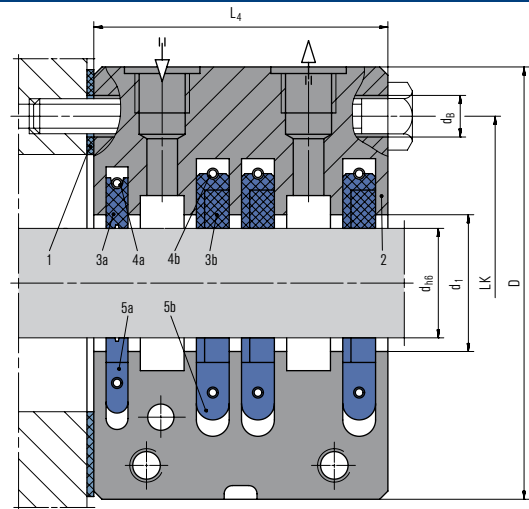

Espey™ WD200/500-WD1S2A1 with barrier gas port and recirculation. The arrangement guarantees a focused barrier gas flow to the process side and keeps gases, solids and mists off the sealing area. In addition the leakage to the outside is reduced and residual gases and condensates will be purged.

Dimensions in mm

d_b	d_1	D	LK	$n \times \varnothing d_b$	S	A	L_1	L_2	L_3	L_4
45	50	175	135	4 x Ø15	1 x G1/2	1 x G1/2	45	55	70	85
50	58	180	140	4 x Ø15	1 x G1/2	1 x G1/2	45	55	70	85
60	70	190	150	4 x Ø15	1 x G1/2	1 x G1/2	45	55	70	85
70	80	200	160	4 x Ø15	1 x G1/2	1 x G1/2	45	55	70	85
80	90	210	170	4 x Ø15	1 x G1/2	1 x G1/2	45	55	70	85
90	100	220	180	4 x Ø15	1 x G1/2	1 x G1/2	45	55	70	85
100	110	230	190	4 x Ø15	1 x G1/2	1 x G1/2	50	60	75	90
110	120	240	200	4 x Ø15	1 x G1/2	1 x G1/2	50	60	75	90
120	130	250	210	4 x Ø15	1 x G1/2	1 x G1/2	50	60	75	90
130	140	260	220	4 x Ø15	1 x G1/2	1 x G1/2	50	60	75	90
140	150	270	230	4 x Ø15	1 x G1/2	1 x G1/2	50	60	75	90
150	160	280	240	4 x Ø15	1 x G1/2	1 x G1/2	50	60	75	90
160	170	290	250	4 x Ø15	1 x G1/2	1 x G1/2	50	60	75	90
170	180	300	260	6 x Ø19	1 x G1/2	1 x G1/2	50	60	75	90
180	190	310	270	6 x Ø19	1 x G1/2	1 x G1/2	50	60	75	90
190	200	320	280	6 x Ø19	1 x G1/2	1 x G1/2	50	60	75	90
200	210	340	290	6 x Ø19	2 x G1/2	1 x G1/2	50	95	80	95
210	220	350	300	6 x Ø19	2 x G1/2	1 x G1/2	50	65	80	95
220	230	360	310	6 x Ø19	2 x G1/2	1 x G1/2	50	65	80	95
230	240	370	320	6 x Ø19	2 x G1/2	1 x G1/2	50	65	80	95
240	250	380	330	6 x Ø19	2 x G1/2	1 x G1/2	50	65	80	95
250	260	390	340	6 x Ø19	2 x G1/2	1 x G1/2	50	65	80	95
260	270	400	350	6 x Ø19	2 x G1/2	1 x G1/2	50	65	80	95
270	280	410	360	6 x Ø19	2 x G1/2	1 x G1/2	50	65	80	95
280	290	420	370	6 x Ø19	2 x G1/2	1 x G1/2	50	65	80	95
290	300	430	380	6 x Ø19	2 x G1/2	1 x G1/2	50	65	80	95
300	310	440	390	6 x Ø19	2 x G1/2	1 x G1/2	50	95	80	95
310	320	450	400	6 x Ø19	2 x G1/2	1 x G1/2	50	65	80	95
320	330	460	410	6 x Ø19	2 x G1/2	1 x G1/2	50	65	80	95
330	340	470	420	6 x Ø19	2 x G1/2	1 x G1/2	50	65	80	95
340	350	480	430	6 x Ø19	2 x G1/2	1 x G1/2	50	65	80	95

S = Barrier gas port, A = Recirculation
 Special sizes on request
 Length L depending on number of seal rings and type

Espey™ WDMS500

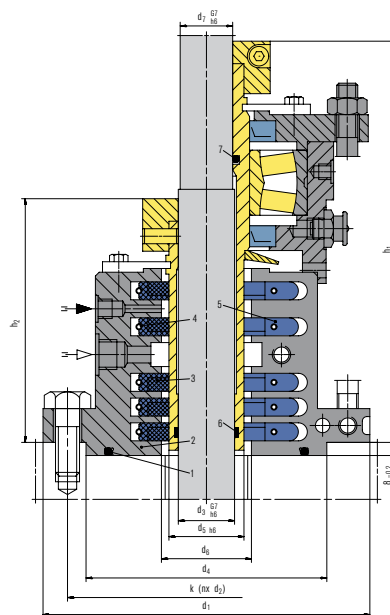

Features

- Multipart seal rings, overlapped mortized with gas-tight joints
- Split housing design
- Lowest possible operation gap – lowest leakage
- Dry-running
- Self-adjusting seal rings
- Seal rings bear radial shaft movements
- Compensates axial shaft movements
- No sealing components mounted on the shaft and hence no additional shaft vibrations
- Cooling sealing area for high temperature applications not required

Advantages

- Easy installation by split housing design (shaft removal not required)
- Long-term operation time
- Maintainability
- Segmented seal rings for easy replacement
- Robust

Item Description

- | | |
|---|---------------------|
| 1 | O-Ring flange |
| 2 | Housing, 2-piece |
| 3 | Seal ring |
| 4 | Tension spring |
| 5 | Detent |
| 6 | O-Ring shaft sleeve |
| 7 | O-Ring bearing |

Operating range (see note on page 4)

Shaft diameter: $d = 40 \dots 220 \text{ mm}$ (1.57" ... 8.66")
 Operating pressure: $p = \text{vacuum} \dots 6 \text{ bar}$ (87 PSI) abs.
 Operating temperature: $t = -40 \text{ }^\circ\text{C} \dots +500 \text{ }^\circ\text{C}$
 ($-40 \text{ }^\circ\text{F} \dots +932 \text{ }^\circ\text{F}$) for carbon, $-40 \text{ }^\circ\text{C} \dots +200 \text{ }^\circ\text{C}$
 ($-40 \text{ }^\circ\text{F} \dots +392 \text{ }^\circ\text{F}$) for PTFE compound
 Sliding velocity: $v_g = \text{max. } 5 \text{ m/s}$ (16 ft/s)
 Radial play: 5.0 mm (0.2")
 Axial movement: theoretically unlimited
 (version without bearing), 2.0 mm (0.08")
 (version with bearing)
 Recommended wear guard: >58 HRC

Materials

Seal ring: Carbon, (PTFE compound)
 Housing: 1.4571, others
 Tension spring/detent: 1.4571

Standards and approvals

- DIN 28154
- DIN 28138
- FDA

Recommended applications

- Chemical industry
- Petrochemical industry
- Food processing industry
- Water and waste water technology
- Gases*
- Solids containing, flammable (ATEX), toxic gases*
- (Solids containing) steams/liquid mist*
- Oil mist/penetrating oil*
- Dust/powder*
- Agitators
- Mixers
- Dryers
- Filters

* Sealing area



Seal ring Espey™ WDMS500 (multi-part, overlapped mortized)

Espey™ WDM500

Dimensions in mm

d_3	d_7	d_5	d_6	d_4	d_1	k	n	d_2	h_1	h_2
40	38	50	58	110	75	145	4	18	213	135
50	48	60	68	176	240	210	8	18	221	140
60	58	70	78	176	240	210	8	18	235	150
80	78	90	100	204	275	240	8	22	260	160
100	98	110	120	234	305	270	8	22	283	165
125	120	140	150	260	330	295	8	22	309	170
140	135	160	170	313	395	350	12	22	337	185
160	150	180	190	313	395	350	12	22	337	185
180	170	200	210	364	445	400	12	22	369	195
200	190	220	230	364	445	400	12	22	381	195
220	210	240	250	422	505	460	16	22	401	205

Special sizes on request



Agitator in a chemical plant

Espey™ WKA300

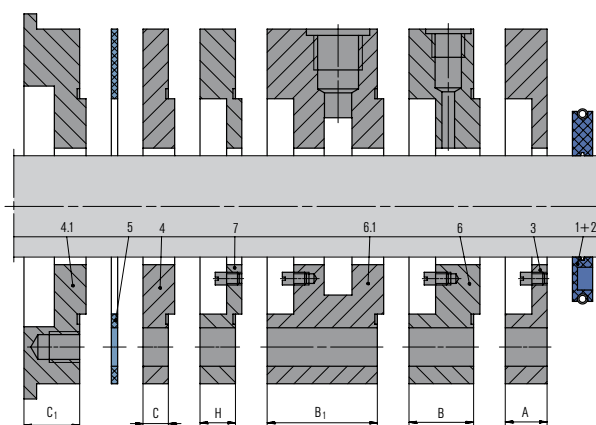
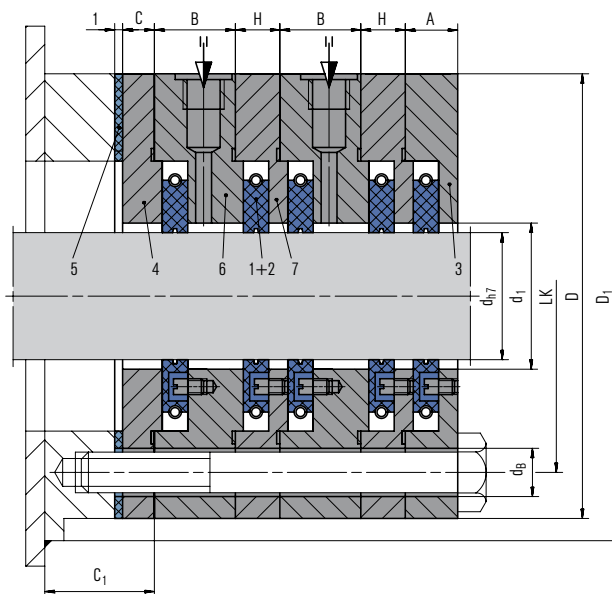

Features

- Multi-part seal rings, radially cut
- Chamber seal (modular design – can be combined in any order)
- Very small operation gap – low leakage
- Dry running
- Self-adjusting seal rings
- Seal rings bear radial shaft movements
- Compensates axial shaft movements
- No sealing components mounted on the shaft and hence no additional shaft vibrations
- Seal rings running contact-free – sliding faces and machine consume no additional power

Advantages

- Segmented seal rings for easy replacement
- High reliability
- Long-term operation time
- Maintainability

Operating range (see note on page 4)

Shaft diameter: $d = 20 \dots 300 \text{ mm}$ (0.79" ... 11.81")
 Operating pressure: $p = \text{vacuum} \dots 1.5 \text{ bar}$ (22 PSI) abs.
 Operating temperature: $t = -120 \text{ }^\circ\text{C} \dots +500 \text{ }^\circ\text{C}$
 (-184 °F ... +932 °F) for carbon, max. 225 °C
 (437 °F) for PTFE compound, max. 300 °C (572 °F)
 with grease
 Sliding velocity: $v_g = \text{max. } 150 \text{ m/s}$ (492 ft/s) for carbon, max. 40 m/s (131 ft/s) for PTFE compound
 Radial play: 2.0 mm (0.08")
 Axial movement: theoretically unlimited
 Recommended wear guard: > 300 HB

Item Description

- | | |
|-----|-------------------------------|
| 1 | Seal ring |
| 2 | Tension spring |
| 3 | Chamber |
| 4 | End ring |
| 4.1 | Welding ring (as alternative) |
| 5 | Flat seal |
| 6 | Grease chamber |
| 6.1 | Barrier gas, suction chamber |
| 7 | Intermediate chamber |

Materials

Seal ring: Carbon, PTFE compound
 Chamber parts: 1.4571, Hastelloy™, Titanium, Inconel™, others
 Tension spring: 1.4571, Hastelloy™, Titanium, Inconel™

Standards and approvals

- FDA

Recommended applications

- Chemical industry
- Metal production and processing
- Pulp and paper industry
- Food processing industry
- Power plant technology
- Machinery and plant building
- Gases
- Fumes and exhaust, solids containing, flammable (ATEX), acid containing and toxic gases
- (Solids containing) steams/liquid mist
- Oil mist/penetrating oil
- Water
- Small and medium-sized fans/blowers
- Bearing seals (gear box, motors)
- Mixers, agitators, mills, dryers

Espey™ WKA300

Product variants

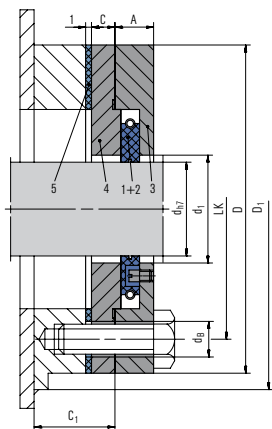

Espey™ WKA301/4 (up to 225 °C (437 °F)) or **Espey™ WKA302/4** (up to 500 °C (932 °F)) for clean media, not for solids containing gases.

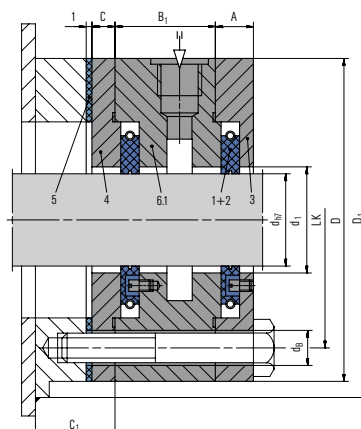

Espey™ WKA303.2/4 (up to 225 °C (437 °F)) or **Espey™ WKA304.2/4** (up to 500 °C (932 °F)) with barrier gas port for toxic and solids containing media as well as ATEX applications.

Dimensions in mm

d _{h7}	d ₁	d _g	D	D ₁	LK	A	B	B ₁	C	C ₁	H
20	24	10	95	110	75	12	21	38	5	21	10
25	29	10	100	115	80	12	21	38	5	21	10
30	34	10	105	120	85	12	21	38	5	21	10
35	39	10	110	125	90	12	21	38	5	21	10
40	44	10	115	130	95	12	21	38	5	21	10
45	49	12	130	145	105	12	21	38	5	30	10
50	54	12	140	155	115	12	21	38	5	30	10
55	59	12	145	160	120	12	21	38	5	30	10
60	64	12	150	165	125	12	21	38	5	30	10
65	69	12	155	170	130	12	21	38	5	30	10
70	74	12	160	175	135	12	21	38	5	30	10
75	79	12	165	180	140	12	21	38	5	30	10
80	84	12	170	185	145	12	21	38	5	30	10
85	89	12	175	190	150	12	21	38	5	30	10
90	94	12	180	195	155	12	21	38	5	30	10
95	99	12	185	200	160	12	21	38	5	30	10
100	104	12	190	205	165	12	21	38	5	30	10
105	109	12	195	210	170	12	21	38	5	30	10
110	114	12	200	215	175	12	21	38	5	30	10
120	124	14	220	235	190	14	23	40	7	30	12
130	134	14	230	245	200	14	23	40	7	30	12
140	144	14	240	255	210	14	23	40	7	30	12
150	154	14	250	265	220	14	23	40	7	30	12
160	164	14	260	275	230	14	23	40	7	30	12
170	174	14	270	285	240	14	23	40	7	30	12
180	184	14	280	295	250	14	23	40	7	30	12
190	194	14	290	305	260	14	23	40	7	30	12
200	204	14	300	315	270	14	23	40	7	30	12
210	214	14	310	325	280	16	23	40	10	30	14
220	224	14	320	335	290	16	23	40	10	30	14
230	234	14	330	345	300	16	23	40	10	30	14
240	244	14	340	355	310	16	23	40	10	30	14
250	254	14	350	365	320	16	23	40	10	30	14
260	264	14	360	375	330	16	23	40	10	30	14
270	274	14	370	385	340	16	23	40	10	30	14
280	284	14	380	395	350	16	23	40	10	30	14
290	294	14	390	405	360	16	23	40	10	30	14
300	304	14	400	415	370	16	23	40	10	30	14

Special sizes on request

Espey™ WKA250ND

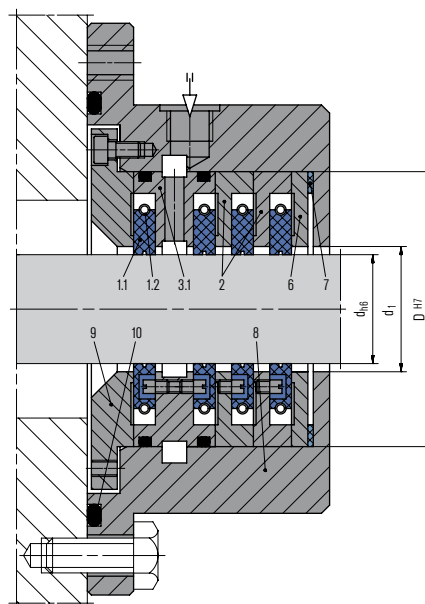

Features

- Chamber seal (modular design – can be combined in any order), optional with housing and lid
- Multi-part seal rings, radially cut
- Very small operation gap – low leakage
- Dry running
- Self-adjusting seal rings
- Seal rings bear radial shaft movements
- Compensates axial shaft movements
- No sealing components mounted on the shaft and hence no additional shaft vibrations
- Seal rings running contact-free – sliding faces and machine consume no additional power
- Balanced seal ring inside chamber

Advantages

- High reliability
- Long-term operation time
- Maintainability
- Segmented seal rings for easy replacement



Fan
Photo: Piller Industrieventilatoren GmbH

Item Description

Item	Description	Variable for width
1.1	Seal ring	
1.2	Tension spring	
2	Chamber	A
2.1	Chamber with O-Ring	A
3	Barrier gas chamber	B
3.1	Barrier gas chamber with O-Rings	B
4	Lantern chamber	C
4.1	Lantern chamber with O-Ring	C
5	Lantern	E
6	End ring	G
7	Flat seal	H
8*	Housing	
9*	Lid	
10*	O-Ring housing	

*On request

Operating range (see note on page 4)

Shaft diameter: $d = 20 \dots 300 \text{ mm}$ (0.79" ... 11.81")
 Operating pressure: $p = \text{vacuum} \dots 15 \text{ bar}$ (218 PSI) abs.
 Operating temperature: $t = -120 \text{ }^\circ\text{C} \dots +500 \text{ }^\circ\text{C}$
 (-184 °F ... +932 °F) for carbon, max. 225 °C (437 °F) for PTFE compound
 Sliding velocity: $v_g = \text{max. } 240 \text{ m/s}$ (787 ft/s) for carbon, max. 40 m/s (131 ft/s) for PTFE compound
 Radial play: 2.0 mm (0.08")
 Axial movement: theoretically unlimited
 Recommended wear guard: > 58 HRC

Materials

Seal ring: Carbon, PTFE compound
 Chamber and housing parts: 1.4021, 1.4571, Hastelloy™, Titanium, Inconel™, others
 Tension spring: 1.4571, Hastelloy™, Titanium, Inconel™
 Secondary seal (elastomer): Fluorocarbon rubber (Viton™), Nitrile-butadiene-rubber (Perbunan™), Perfluorocarbon rubber (Kalrez™)
 Secondary seal (gasket): Statotherm™-HT/HD, KSil C 4400

Standards and approvals

- FDA

Recommended applications

- Oil and gas industry
- Refining technology
- Chemical industry
- Petrochemical industry
- Pulp and paper industry
- Metal production and processing
- Power plant technology
- Gases
- Fumes and exhaust, solids containing, flammable (ATEX), acid containing and toxic gases
- (Solids containing) steams/liquid mist
- Oil mist/penetrating oil
- Water
- Integral-gear compressors (one or multi-stage)
- Screw and chiller compressors
- Steam turbines
- Regulating devices

Espey™ WKA250ND

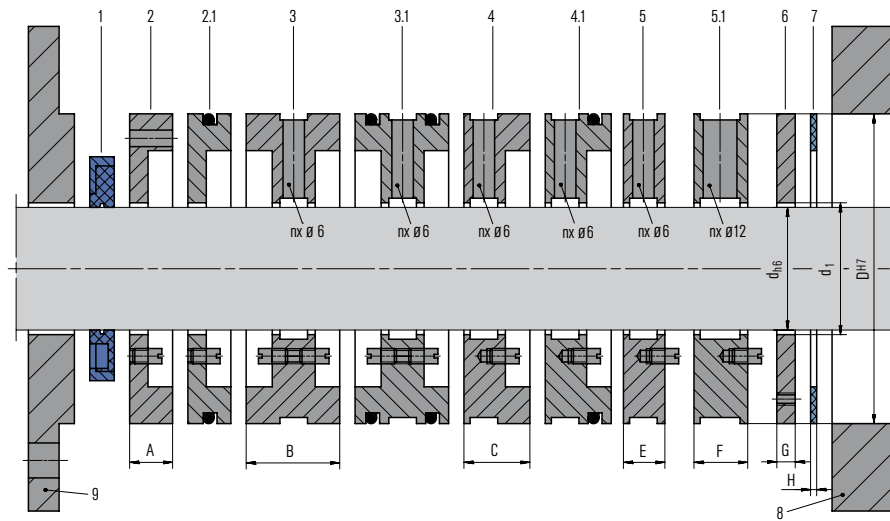

Dimensions in mm

d_{h6}	D^{H7}	d_1	A	B	C	E	F	G	H
20	60	22	8	21	16	11	-	5	1
25	65	27	8	21	16	11	-	5	1
30	70	32	8	21	16	11	-	5	1
35	75	37	8	21	16	11	-	5	1
40	80	42	8	21	16	11	-	5	1
45	90	47	8	21	16	11	-	5	1
50	100	52	8	21	16	11	17	5	1
55	105	57	8	21	16	11	17	5	1
60	110	62	8	21	16	11	17	5	1
65	115	67	8	21	16	11	17	5	1
70	120	72	8	21	16	11	17	5	1
75	125	77	8	21	16	11	17	5	1
80	130	82	8	21	16	11	17	5	1
85	135	87	8	21	16	11	17	5	1
90	140	92	8	21	16	11	17	5	1
95	145	97	8	21	16	11	17	5	1
100	150	102	8	21	16	11	17	5	1
105	155	107	8	21	16	11	17	5	1
110	160	112	8	21	16	11	17	5	1
115	165	117	8	21	16	11	17	5	1
120	190	123	10	27	21	15	20	8	2
130	200	133	10	27	21	15	20	8	2
140	210	143	10	27	21	15	20	8	2
150	220	153	10	27	21	15	20	8	2
160	230	163	10	27	21	15	20	8	2
170	240	173	10	27	21	15	20	8	2
180	250	183	10	27	21	15	20	8	2
190	260	193	10	27	21	15	20	8	2
200	270	203	10	27	21	15	20	8	2
210	280	213	10	27	21	15	20	8	2
220	290	223	10	27	21	15	20	8	2
230	300	233	10	27	21	15	20	8	2
240	310	243	10	27	21	15	20	8	2
250	320	253	10	27	21	15	20	8	2
260	330	263	10	27	21	15	20	8	2
270	340	273	10	27	21	15	20	8	2
280	350	283	10	27	21	15	20	8	2
290	360	293	10	27	21	15	20	8	2
300	370	303	10	27	21	15	20	8	2

Special sizes on request

Espey™ WKA400HD

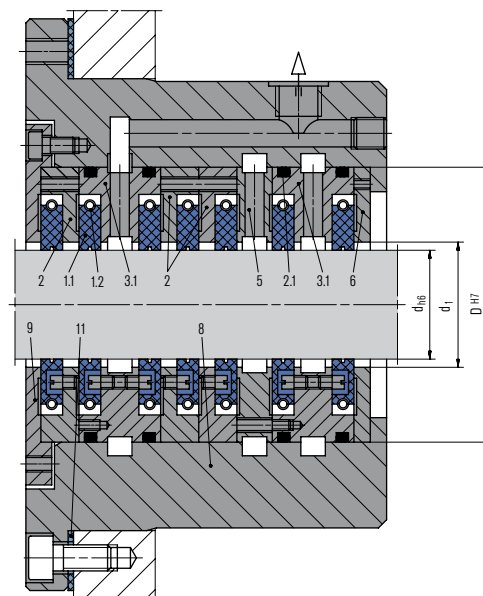
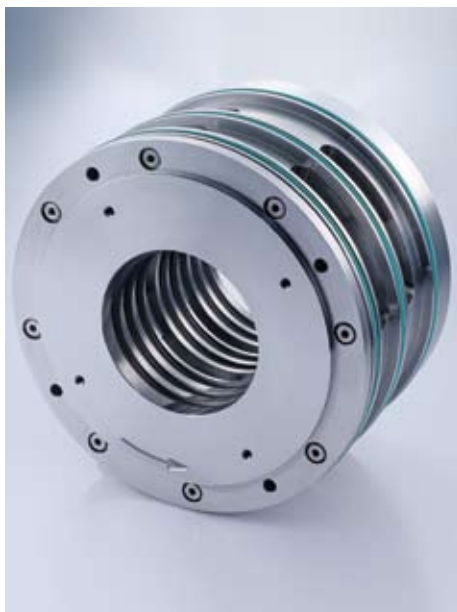

Features

- Chamber seal (modular design – can be combined in any order), optional with housing and lid
- Multi-part seal rings, radially cut
- Very small operation gap – low leakage
- Dry running
- Self-adjusting seal rings
- Seal rings bear radial shaft movements
- Compensates axial shaft movements
- No sealing components mounted on the shaft and hence no additional shaft vibrations
- Seal rings running contact-free – sliding faces and machine consume no additional power
- Balanced seal ring inside chamber

Advantages

- High reliability
- Long-term operation time
- Maintainability
- Segmented seal rings for easy replacement



Steam turbine, lignite-fired power plant

Item Description

Variable for width

1.1	Seal ring	
1.2	Tension spring	
2	Chamber	A
2.1	Chamber with O-Ring	A
3	Barrier gas chamber	B
3.1	Barrier gas chamber with O-Rings	B
4	Lantern chamber	C
4.1	Lantern chamber with O-Ring	C
5	Lantern	E
6	End ring	G
7	Flat seal	H
8*	Housing	
9*	Lid	
11*	Flat seal housing	

*On request

Materials

Seal ring: Carbon
 Chamber and housing parts: 1.4021, 1.4571, Hastelloy™, Titanium, Inconel™, others
 Tension spring: 1.4571, Hastelloy™, Titanium, Inconel™
 Secondary seal (elastomer): Fluorocarbon rubber (Viton™), Nitrile-butadiene-rubber (Perbunan™), Perfluorocarbon rubber (Kalrez™)
 Secondary seal (gasket): Statotherm™-HT/HD, KSiL C 4400

Standards and approvals

- FDA

Recommended applications

- Oil and gas industry
- Refining technology
- Chemical industry
- Petrochemical industry
- Pulp and paper industry
- Metal production and processing
- Power plant technology
- Gases
- Fumes and exhaust, solids containing, flammable (ATEX), acid containing and toxic gases
- (Solids containing) steams/liquid mist
- Oil mist/penetrating oil
- Water
- Integral-gear compressors (one or multi-stage)
- Screw and chiller compressors
- Steam turbines
- Regulating devices

Operating range (see note on page 4)

Shaft diameter: $d = 20 \dots 300 \text{ mm}$ (0.79" ... 11.81")
 Operating pressure: $p = \text{vacuum} \dots 75 \text{ bar}$ (1,088 PSI) abs.
 Operating temperature: $t = -120 \text{ °C} \dots +500 \text{ °C}$
 (-184 °F ... +932 °F)
 Sliding velocity: $v_g = \text{max. } 240 \text{ m/s}$ (787 ft/s)
 Radial play: $1.0 \dots 2.0 \text{ mm}$ (0.04" ... 0.08")
 Axial movement: theoretically unlimited
 Recommended wear guard: $> 58 \text{ HRC}$

Espey™ WKA400HD

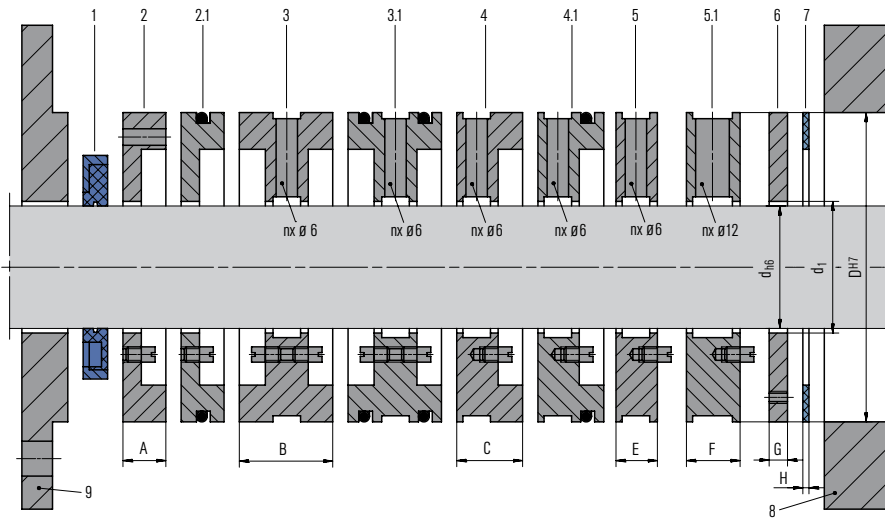

Dimensions in mm

d_{h6}	D_{H7}	d_1	A	B	C	E	F	G	H
20	60	22	10	21	16	11	-	5	1
25	65	27	10	21	16	11	-	5	1
30	70	32	10	21	16	11	-	5	1
35	75	37	10	21	16	11	-	5	1
40	80	42	10	21	16	11	-	5	1
45	90	47	10	21	16	11	-	5	1
50	100	52	10	21	16	11	17	5	1
55	105	57	10	21	16	11	17	5	1
60	110	62	10	21	16	11	17	5	1
65	115	67	10	21	16	11	17	5	1
70	120	72	10	21	16	11	17	5	1
75	125	77	10	21	16	11	17	5	1
80	130	82	10	21	16	11	17	5	1
85	135	87	10	21	16	11	17	5	1
90	140	92	10	21	16	11	17	5	1
95	145	97	10	21	16	11	17	5	1
100	150	102	10	21	16	11	17	5	1
105	155	107	10	21	16	11	17	5	1
110	160	112	10	21	16	11	17	5	1
115	165	117	10	21	16	11	17	5	1
120	190	123	12	27	21	15	20	8	2
130	200	133	12	27	21	15	20	8	2
140	210	143	12	27	21	15	20	8	2
150	220	153	12	27	21	15	20	8	2
160	230	163	12	27	21	15	20	8	2
170	240	173	12	27	21	15	20	8	2
180	250	183	12	27	21	15	20	8	2
190	260	193	12	27	21	15	20	8	2
200	270	203	12	27	21	15	20	8	2
210	280	213	12	27	21	15	20	8	2
220	290	223	12	27	21	15	20	8	2
230	300	233	12	27	21	15	20	8	2
240	310	243	12	27	21	15	20	8	2
250	320	253	12	27	21	15	20	8	2
260	330	263	12	27	21	15	20	8	2
270	340	273	12	27	21	15	20	8	2
280	350	283	12	27	21	15	20	8	2
290	360	293	12	27	21	15	20	8	2
300	370	303	12	27	21	15	20	8	2

Special sizes on request

Espey™ WKA802HD

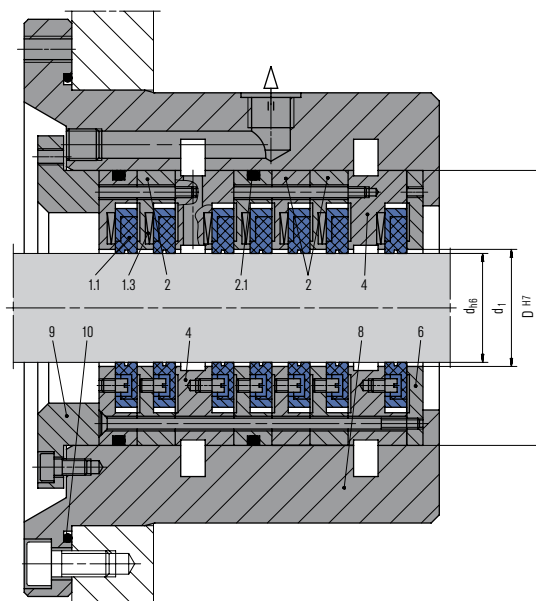

Features

- Chamber seal (modular design – can be combined in any order), optional with housing and lid
- Very small operation gap – low leakage
- Dry running
- Seal rings bear radial shaft movements
- Compensates axial shaft movements
- No sealing components mounted on the shaft and hence no additional shaft vibrations
- Seal rings running contact-free – sliding faces and machine consume no additional power
- One-piece seal ring with titanium bandage
- Balanced seal ring inside chamber
- Seal ring axially spring-loaded – no swinging up at pressure-less machine operation

Advantages

- High reliability
- Long-term operation time
- Maintainability

Operating range (see note on page 4)

Shaft diameter: $d = 20 \dots 200 \text{ mm}$ (0.79" ... 7.87")
 Operating pressure: $p = \text{vacuum} \dots 140 \text{ bar}$ (2,031 PSI) abs.
 Operating temperature: $t = -120 \text{ }^\circ\text{C} \dots +225 \text{ }^\circ\text{C}$ (-184 °F ... +437 °F)
 Sliding velocity: $v_g = \text{max. } 240 \text{ m/s}$ (787 ft/s)
 Radial play: 1.0 mm (0.04")
 Axial movement: theoretically unlimited
 Recommended wear guard: > 58 HRC

Item Description

Item	Description	Variable for width
1.1	Seal ring	
1.3	Pressure spring	
2	Chamber	A
2.1	Chamber with O-Ring	A
3	Barrier gas chamber	B
3.1	Barrier gas chamber with O-Rings	B
4	Lantern chamber	C
4.1	Lantern chamber with O-Ring	C
5	Lantern thin	E
5.1	Lantern wide	F
6	End ring	G
7	Flat seal	H
8*	Housing	
9*	Lid	
10*	O-Ring housing	
11*	Flat seal housing	

*On request

Materials

Seal ring: Carbon with titanium bandage
 Chamber and housing parts: 1.4021, 1.4571, Hastelloy™, Titanium, Inconel™, others
 Secondary seal (elastomer): Fluorocarbon rubber (Viton™), Nitrile-butadiene-rubber (Perbunan™), Perfluorocarbon rubber (Kalrez™)
 Secondary seal (gasket): Statotherm™-HT/HD, KSil C 4400

Standards and approvals

- FDA

Recommended applications

- Oil and gas industry
- Refining technology
- Chemical industry
- Petrochemical industry
- Pulp and paper industry
- Metal production and processing
- Power plant technology
- Gases
- Fumes and exhaust, solids containing, acid containing and toxic gases
- (Solids containing) steams/liquid mist
- Oil mist/penetrating oil
- Water
- Integral-gear compressors (one or multi-stage)
- Screw and chiller compressors
- Steam turbines
- Regulating devices



Multi-stage gear compressor
 Photo: MAN Diesel & Turbo SE

Espey™ WKA802HD

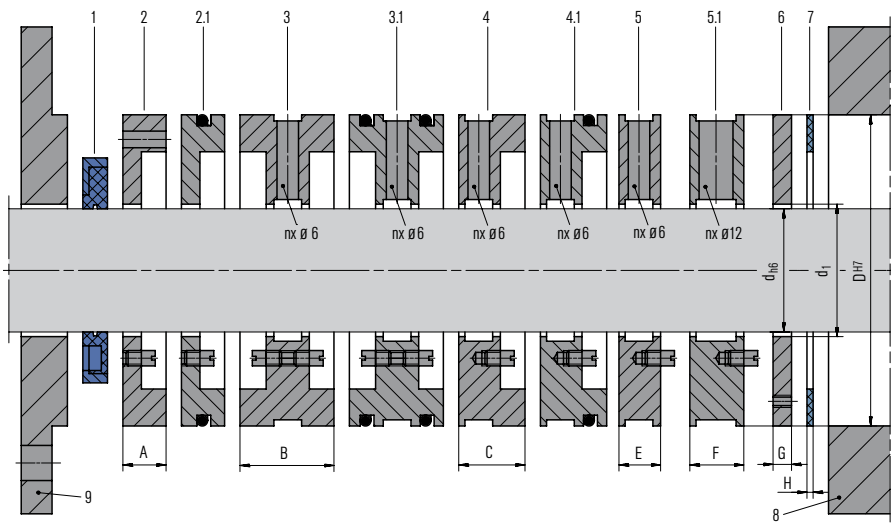

Dimensions in mm

d_{h6}	D^{H7}	d_1	A	B	C	E	F	G	H
20	80	22	10	21	16	11	17	5	1
25	85	27	10	21	16	11	17	5	1
30	90	32	10	21	16	11	17	5	1
35	95	37	10	21	16	11	17	5	1
40	100	42	10	21	16	11	17	5	1
45	105	47	10	21	16	11	17	5	1
50	110	52	10	21	16	11	17	5	1
55	115	57	10	21	16	11	17	5	1
60	120	62	10	21	16	11	17	5	1
65	125	67	10	21	16	11	17	5	1
70	130	72	10	21	16	11	17	5	1
75	135	77	10	21	16	11	17	5	1
80	140	82	10	21	16	11	17	5	1
85	145	87	10	21	16	11	17	5	1
90	150	92	10	21	16	11	17	5	1
95	155	97	10	21	16	11	17	5	1
100	160	102	10	21	16	11	17	5	1
105	165	107	10	21	16	11	17	5	1
110	170	112	10	21	16	11	17	5	1
115	175	117	10	21	16	11	17	5	1
120	190	122	12	27	19	15	20	8	2
130	200	132	12	27	19	15	20	8	2
140	210	142	12	27	19	15	20	8	2
150	220	152	12	27	19	15	20	8	2
160	230	162	14	31	21	15	20	8	2
170	240	172	14	31	21	15	20	8	2
180	250	182	14	31	21	15	20	8	2
190	260	192	14	31	21	15	20	8	2
200	270	202	14	31	21	15	20	8	2

Special sizes on request

Espey™ WKA1100HP

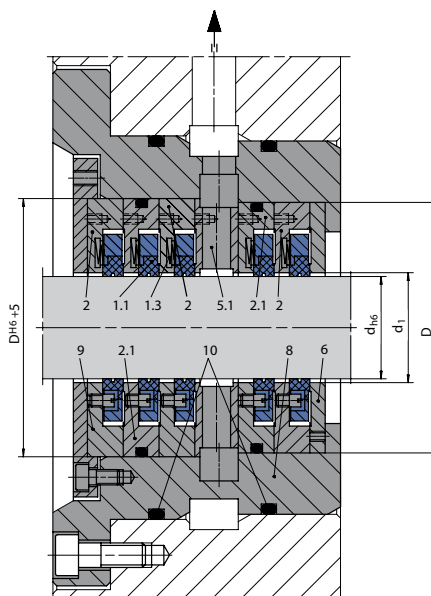

Features

- Chamber seal (modular design – can be combined in any order), optional with housing and lid
- Very small operation gap – low leakage
- Dry running
- Seal rings bear radial shaft movements
- Compensates axial shaft movements
- No sealing components mounted on the shaft and hence no additional shaft vibrations
- Seal rings running contact-free – sliding faces and machine consume no additional power
- One-piece seal ring with titanium bandage
- Both side balanced seal ring inside chamber for short-term backpressure operation
- Seal ring axially spring-loaded – no swinging up at pressure-less machine operation

Advantages

- High reliability
- Long-term operation time
- Maintainability

Operating range (see note on page 4)

Shaft diameter: $d = 20 \dots 200 \text{ mm}$ (0.79" ... 7.87")
 Operating pressure: $p = \text{vacuum} \dots 250 \text{ bar}$ (3,626 PSI) abs.
 Operating temperature: $t = -120 \text{ }^\circ\text{C} \dots +225 \text{ }^\circ\text{C}$ (-184 °F ... +437 °F)
 Sliding velocity: $v_g = \text{max. } 240 \text{ m/s}$ (787 ft/s)
 Radial play: 1.0 mm (± 0.04 ")
 Axial movement: theoretically unlimited
 Recommended wear guard: > 58 HRC

Item Description

Variable for width

Item	Description	Variable for width
1.1	Seal ring	
1.3	Pressure spring	
2	Chamber	A
2.1	Chamber with O-Ring	A
3	Barrier gas chamber	B
3.1	Barrier gas chamber with O-Rings	B
4	Lantern chamber	C
4.1	Lantern chamber with O-Ring	C
5	Lantern thin	E
5.1	Lantern wide	F
6	End ring	G
7	Flat seal	H
8*	Housing	
9*	Lid	
10*	O-Ring housing	

*On request

Materials

Seal ring: Carbon with titanium bandage
 Chamber and housing parts: 1.4021, 1.4571, Hastelloy™, Titanium, Inconel™, others
 Secondary seal (elastomer): Fluorocarbon rubber (Viton™), Nitrile-butadiene-rubber (Perbunan™), Perfluorocarbon rubber (Kalrez™)
 Secondary seal (gasket): Statotherm™-HT/HD, KSil C 4400

Standards and approvals

- FDA

Recommended applications

- Oil and gas industry
- Refining technology
- Chemical industry
- Petrochemical industry
- Pulp and paper industry
- Metal production and processing
- Power plant technology
- Gases
- Fumes and exhaust, solids containing, acid containing and toxic gases
- (Solids containing) steams/liquid mist
- Oil mist/penetrating oil
- Water
- Integral-gear compressors (one or multi-stage)
- Screw and chiller compressors



Multi-stage gear compressor
 Photo: Siemens AG

Espey™ WKA1100HP

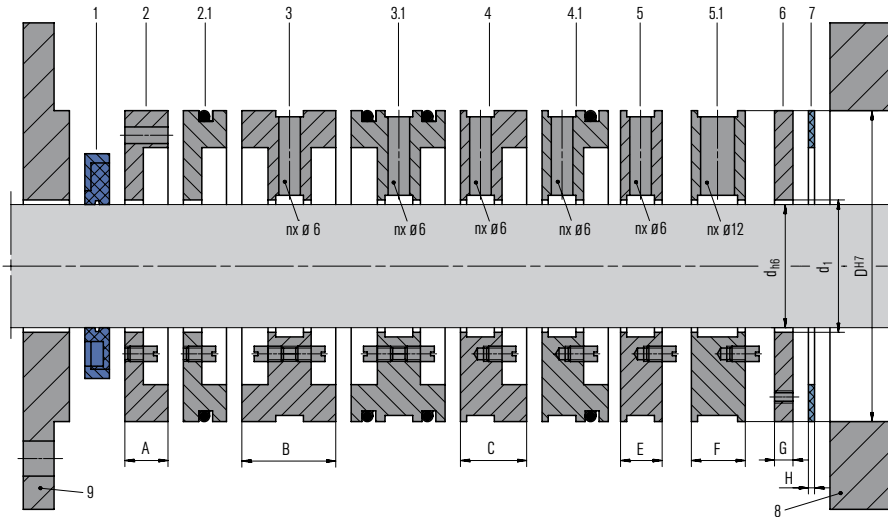

Dimensions in mm

d_{h6}	D	d_1	A	G	H
20	85	22	11	5	1
25	90	27	11	5	1
30	95	32	11	5	1
35	100	37	11	5	1
40	105	42	11	5	1
45	110	47	11	5	1
50	115	52	11	5	1
55	120	57	11	5	1
60	125	62	11	5	1
65	130	67	11	5	1
70	135	72	11	5	1
75	140	77	11	5	1
80	145	82	11	5	1
85	150	87	11	5	1
90	155	92	11	5	1
95	160	97	11	5	1
100	165	102	11	5	1
105	170	107	11	5	1
110	175	112	11	5	1
115	180	117	11	5	1
120	185	122	13	5	1
130	195	132	13	5	1
140	205	142	13	5	1
150	215	152	13	5	1
160	225	162	13	5	1
170	235	172	13	5	1
175	240	177	13	5	1
180	245	182	13	5	1
190	255	192	13	5	1
200	265	202	13	5	1

Special sizes on request

Espey™ WDB200

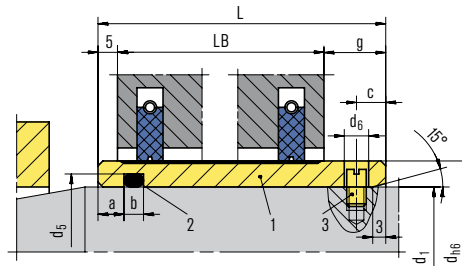
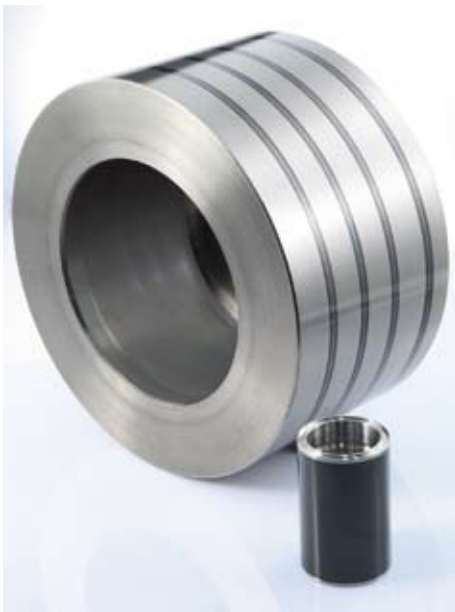

Features

- Torque transmission depending on application with set screw or as shrink fit
- Metallic coating (FMP 84) basically for applications without high oxidation
- Ceramic coating (EMP 98) basically for applications with high oxidation
- Design one- or two-piece

Advantages

- Easy installation by split design (2-piece version)
- High reliability
- Long-term operation time
- Maintainability



2-part shaft sleeve

Operating range (see note on page 4)

FMP 84 (metallic coating)

General description: chromium carbide
 Coating process: flame spray technique (no influence on material structure)
 Shrink acceptability: very good
 Shaft diameter: $d = 45 \dots 340 \text{ mm}$ (1.77" ... 13.39")
 Operating temperature: $t = \text{max. } 1,000 \text{ }^\circ\text{C}$ (1,832 °F)
 Peripheral velocity: $v_u = \text{max. } 240 \text{ m/s}$ (787 ft/s)
 Hardness: $> 65 \text{ HRC}$

EMP 98 (ceramic coating)

General description: chromium oxide (ceramic)
 Coating process: flame spray technique (no influence on material structure)
 Shrink acceptability: with restrictions
 Shaft diameter: $d = 45 \dots 340 \text{ mm}$ (1.77" ... 13.39")
 Operating temperature: $t = \text{max. } 600 \text{ }^\circ\text{C}$ (1,112 °F)
 Peripheral velocity: $v_u = \text{max. } 150 \text{ m/s}$ (492 ft/s)
 Hardness: $> 58 \text{ HRC}$

Item Description

1	Shaft sleeve
2	O-Ring
3	Set screw

Materials

1.4021-FMP, 1.4086, 1.4462-FMP, 1.4571-FMP, others

Standards and approvals

- DIN 42955

Espey™ WDB200

Product variants

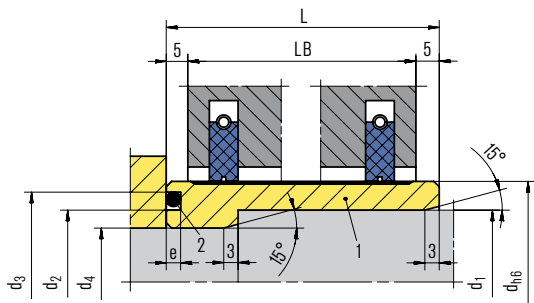

Espey™ WDB212/4 with fit bore shaft sleeve/diameter shaft H6/h6 for low loaded seals e. g. in slow running fans, agitators or shaft sleeve **Espey™ WDB215/4** with fit bore shaft sleeve/diameter shaft M5/h6 for high loaded seals e. g. in turbo compressors, turbines.

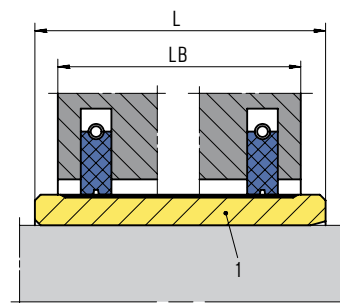

Espey™ WDB216/4 with fit bore shaft sleeve/diameter shaft according to operating conditions and customer specifications e. g. for high pressure turbo compressors and turbines.

Dimensions in mm

d _{h6}	d ₁ *	d ₂	d ₃	d ₄	d ₅	d ₆	a	b	c	e	f	g
45	35	37	42	25.5	38.5	6	5	3	8	1.5	20	15
50	40	42	47	30.5	43.5	6	5	3	8	1.5	20	15
60	50	52	57	40.5	53.5	6	5	3	8	1.5	20	15
70	55	60	67	45.5	60.4	6	5	4	8	2.4	20	15
80	65	70	77	55.5	70.4	6	5	4	8	2.4	20	15
90	75	80	87	65.5	80.4	6	5	4	8	2.4	20	15
100	85	89	97	75.5	91.3	6	7	4.5	8.5	2.8	20	17
110	90	99	107	75.5	96.3	7	7	4.5	8.5	2.8	20	17
120	100	109	117	85.5	106.3	7	7	4.5	8.5	2.8	20	17
130	110	119	127	95.5	116.3	7	7	4.5	8.5	2.8	20	17
140	120	129	137	105.5	126.3	7	7	4.5	8.5	2.8	20	17
150	130	138	146	115.5	136.3	7	7	4.5	8.5	2.8	20	17
160	140	148	156	125.5	146.3	9	7	4.5	9.5	2.8	20	19
170	150	158	166	135.5	156.3	9	7	4.5	9.5	2.8	20	19
180	160	168	176	145.5	166.3	9	7	4.5	9.5	2.8	20	19
190	170	178	186	155.5	176.3	9	7	4.5	9.5	2.8	20	19
200	180	188	196	165.5	186.3	9	7	4.5	9.5	2.8	20	19
220	195	206	215	175.5	202.2	11	8	5	11	3.2	25	22
240	215	226	235	195.5	222.2	11	8	5	11	3.2	25	22
260	235	246	255	215.5	242.2	11	8	5	11	3.2	25	22
280	255	266	275	235.5	262.2	11	8	5	11	3.2	25	22
300	275	286	295	255.5	282.2	11	8	5	11	3.2	30	22
320	295	306	315	275.5	302.2	11	8	5	11	3.2	30	22
340	315	326	335	295.5	322.2	11	8	5	11	3.2	30	22

Special sizes on request
* Consider selection of fits



Vapour compression
Photo: Piller Industrieventilatoren GmbH



PET reactor
Photo: M&G Polimeros Brasil S.A

Application examples carbon floating ring seals

Applications fan/blower

- Metal production and processing: inert gas circulation at metal heat treatment, hot gas circulation in industrial furnaces
- Petrochemical industry/refining technology: gas conveyance, process gas compression, sulphur recovery
- Food processing industry: mechanical vapour compression in creameries
- Power plant technology: exhaust gas neutralization in thermal power plants
- Clean technology: waste air purification in incineration plants
- Chemical industry: solvent recovery

Applications mixer, dryer

- Chemical industry: mixing chloride powders for making herbicides, post-condensation in SSP reactor for PET manufacturing
- Food processing industry: cooking oil production

Applications compressor

- Chemical industry: fertilizer manufacturing, air separation
- Oil and gas industry: gas reinjection, gas-oil separation, gas liquefaction
- Power plant technology: energy recovery

Applications mill

- Cement and lime industry: crushing limestone in ball mills
- Power plant technology: crushing coal for firing steam generators in coal-fired power stations
- Mining industry: grinding resources in mills with gas flow
- Chemical industry: pulverization HDPE granules

Applications centrifuge

- Chemical industry: solid-liquid separation e.g. PE-hexane separation
- Clean technology: dewatering and densification of sludge
- Mining industry: dewatering of sludge
- Food processing industry: phases separation e.g. precipitation of milk sugar



Applications steam turbine

- Power plant technology: wood pellet manufacture for power generation
- Food processing industry: malt boiling in breweries, vapour compression e.g. in the sugar manufacturing
- Power plant technology: combined heat and power
- Pulp and paper industry: paper drying



Other applications

- Shipbuilding: bulkhead seal e.g. in FPSO oil production ships
- Power plant technology: sealing shut-off valves for steam regulation in nuclear power plants
- Power plant technology: sealing oil-lubricated bearing in railway electric converter station



Photographs: Piller Industrieventilatoren GmbH, M&G Polimeros Brasil S.A., MAN Diesel & Turbo SE, Andritz Separation GmbH and others

Quality and certificates



Maritime and naval licences

EagleBurgmann Espey has been awarded various (individual) licences for the Espey™ WDK-BHS bulkhead seal in both aluminium and stainless steel by maritime and naval organisations (including Lloyd's Register EMEA, Bureau Veritas, Russian Maritime Register of Shipping, Germanischer Lloyd and the ABS - American Bureau of Shipping).

Quality management

The high standards we set ourselves not only drive us to produce innovative solutions, but are also reflected in the quality of our products. EagleBurgmann Espey maintains close relations to customers, suppliers and employees as a base for professional, trustful and efficient partnerships. We manufacture along the DIN EN ISO 9001:2008 to attain highest production standards to guarantee the high quality standards of our products and services. This is confirmed by successful operations stretching back over decades and many satisfied customers.

Health and safety management

At EagleBurgmann Espey occupational health and safety is of paramount importance. OHSAS 18001:1999 regulates the reduction of occupational accidents and improvement of employee working conditions.

DIN EN ISO 14001:2005 regulates environmentally-friendly business and human resources management at EagleBurgmann Espey, not to mention environmental awareness concerning the adherence to environmental legislation.

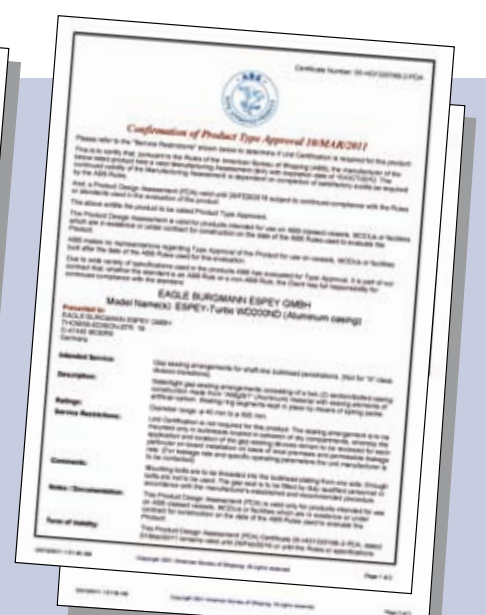

Argentina · Australia · Austria · Belarus · Belgium · Bulgaria · Brazil · Canada · Chile · China · Colombia · Cyprus · Czech Republic · Denmark · Ecuador · Egypt · Estonia
Finland · France · Germany · Great Britain · Greece · Hungary · India · Indonesia · Iraq · Israel · Italy · Japan · Jordan · Kazakhstan · Korea · Kuwait · Latvia · Libya
Lithuania · Malaysia · Mauritius · Mexico · Morocco · Myanmar · Netherlands · New Zealand · Nigeria · Norway · Oman · Pakistan · Paraguay · Peru · Philippines · Poland
Qatar · Romania · Russia · Saudi Arabia · Singapore · Slovenia · Slovakian Republic · South Africa · Spain · Sweden · Switzerland · Syria · Taiwan · Thailand · Trinidad and
Tobago · Tunisia · Turkey · Turkmenistan · Ukraine · United Arab Emirates · Uruguay · USA · Uzbekistan · Venezuela · Vietnam · www.eagleburgmann.com/world



EBES / E1 / 2000 / 07:11 / 5.1.1 © EagleBurgmann Espey, Germany

EagleBurgmann is one of the leading international companies for industrial sealing technology. Our products are used everywhere when safety and reliability are important: In the oil and gas industries, petroleum refining, chemicals, pharmaceutical, energy, food, paper, water, marine applications, aerospace and mining. Every day, more than 5,500 employees contribute their ideas, solutions and commitment to ensuring that customers all over the world can rely on our seals. Our modular seal service, TotalSealCare, underlines our commitment to customer orientation and our provision of tailor-made services for every application.

EagleBurgmann Espey GmbH

Thomas-Edison-Strasse 19
47445 Moers, Germany
Tel. +49 (0)2841 99827 0
Fax +49 (0)2841 99827 56
info.espey@de.eagleburgmann.com
www.eagleburgmann-espey.com

EagleBurgmann®
Rely on excellence