

Multi Line Systems

Enhancing performance



Groeneveld-BEKA

Reducing customers' operational costs and at the same time increasing uptime, productivity, efficiency and safety of their vehicles and machines. That is what it's all about at Groeneveld-BEKA. We accomplish this by developing, producing, supplying and servicing industry-leading automatic lubrication, fluid control and safety support systems.

Groeneveld-BEKA, part of The Timken Company, is the world's second largest producer of automatic lubrication systems, fluid management and safety support systems. Groeneveld-BEKA products improve equipment lifetime and reliability, while reducing the total cost of ownership.

Groeneveld-BEKA was formed through the merger of two well-established companies: Groeneveld and BEKA. Groeneveld was founded in 1971 and acquired by Timken in 2017. BEKA was founded in 1927 and acquired by Timken in late 2019. Groeneveld has also incorporated Interlube into their brand. Interlube was acquired by Timken in 2013.

Groeneveld-BEKA products are supplied for ex-factory installs to leading manufacturers of trucks, trailers, buses, wind turbines, industrial applications, agricultural, mining and construction equipment. In addition Groeneveld-BEKA systems are installed in the after-market for a wide variety of transport, construction, agricultural, port equipment and industrial applications. Groeneveld-BEKA strives to develop and manufacture all of its products in-house according to World Class Manufacturing principles.

Automatic Lubrication Systems

Groeneveld-BEKA offers dedicated automatic lubrication systems for all kinds of equipment in a wide variety of market segments, from the smallest excavator to the largest trucks and industrial applications. The application of our high-end systems leads to decreased wear and tear of critical components resulting in extended lifetime, less downtime and reduced repair and maintenance costs. In short: higher productivity and lower operational costs. As maintenance technicians no longer have to climb on or crawl under the equipment, Groeneveld-BEKA's automatic lubrication systems also contribute to safety.

For optimal greasing in all circumstances Groeneveld-BEKA also offers the right type of grease for every application and every system. This is your guarantee for many years of trouble-free operation of your system and perfect lubrication of your valuable equipment.

Fluid Control

Groeneveld-BEKA's fluid management systems reduce daily maintenance and minimize the risk of unexpected downtime by controlling engine oil levels or removing contamination. Next to the oil management systems, Groeneveld-BEKA also offers systems which easily convey hydraulic power from fixed to moving points.

Safety Support Systems

For many years, Groeneveld-BEKA supplies safety support systems for a wide range of applications. Speedlimiters as well as obstacle detection and camera systems by Groeneveld-BEKA increase safety in many segments from road transport to construction, port, terminal and internal transport.

The World of Lubrication

Groeneveld-BEKA is a global enterprise with a worldwide coverage. In many countries, the company is also represented by independent distributors and dealers – all just as driven as our own organisation to offer added value to the customer's company.

With decades of experience providing reliability services to a range of industries, Groeneveld-BEKA offers complete automated maintenance solutions for all your needs. Groeneveld-BEKA's reliability products maintain your equipment, helping you increase uptime and improve profitability.

Visit the Groeneveld-BEKA website for contact details of our subsidiaries, distributors and service dealers.

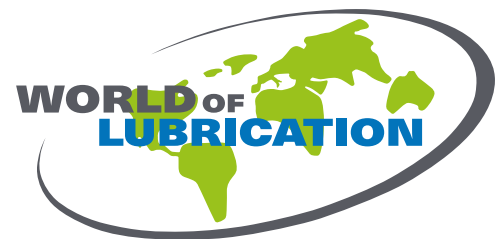

Less maintenance, improved efficiency and lower costs

In today's demanding industrial environment it is critical that machines generate an acceptable level of profit. Whether you are an owner, operator or a plant manager, one of the most cost effective ways of achieving this objective is by employing the use of fully automatic lubrication systems.

Groeneveld-BEKA's automatic lubrication systems have been proven to extend bearing life compared with manual greasing, dramatically cutting the cost of bearing replacements, reducing downtime and improving efficiency and safety.

The benefits

The benefits of automatic lubrication are clear: better greasing of critical components, no time wasted on manual lubrication and the certainty that the equipment will always be greased independent of weather conditions, time schedules or operators. All resulting in significant cost savings.

Reduced man-hours required to lubricate.

- Improved availability of personnel for technical activities.
- Reduced lubricant spillage that occurs with manual lubrication.

Higher equipment productivity

Reduced equipment downtime by ca. 15% resulting from:

- Lubrication taking place during normal machine operation.
- Better and uniform greasing of all critical components because bearings and pins and bushings are in motion when lubrication takes place, resulting in less wear and tear of machinery.

Decreased maintenance

- With manual lubrication, grease will follow the path of least resistance due to the fact that greasing has to take place under static conditions. So, the grease is not equally distributed around the lubrication point. Automatic greasing avoids this, as lubrication will take place during operation, reducing wear of critical components.
- Reduced replacement rate of components and bearings up to 50%.
- Decreased machine labour costs by ~ 50%.

Improved safety

- No climbing on and around machinery or inaccessible areas.

Effectiveness of Automatic Lubrication

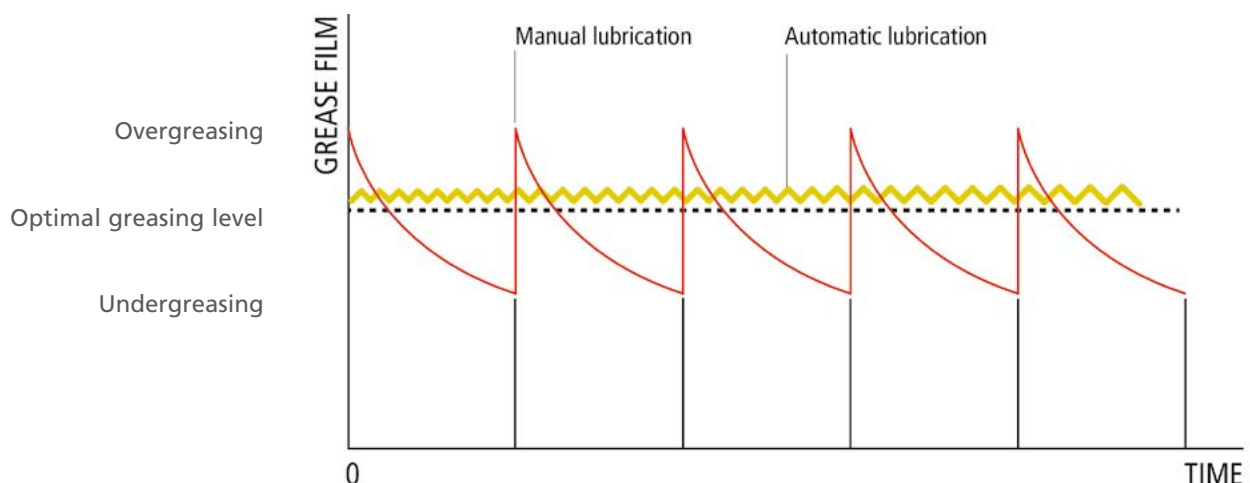

Multi line systems

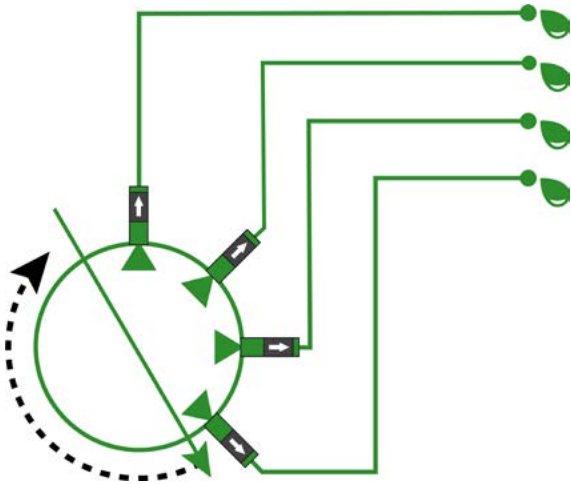

Multi line systems are commonly called “Pump to point” systems as lubricant is fed directly from each of the pumping elements in the pump body via its own line to the lubrication point.

The advantage of multi line system is the flexibility to configure the system for the lubrication points required, simply reduce the number of outputs or adjust the output by replacing the injectors.

Groeneveld-BEKA multi line systems are mainly designed for self install.

We offer multi line systems suitable for up to 60 points and capable of operating oil or greases from NLGI-0 up to NLGI-2.

Multi line systems for all kinds of applications



Trucks



Trailers



Truck Mounted Cranes



Sweepers



Bus & Coach



Agricultural attachments



Forklifts

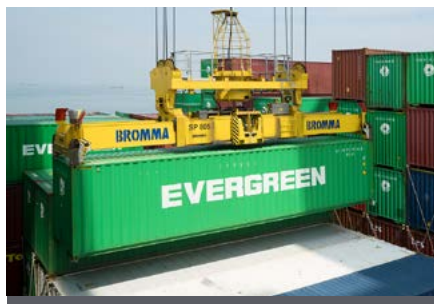

Spreaders

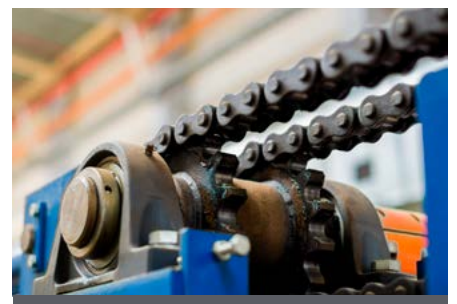

Drive chains

Groeneveld MultiLine

The Groeneveld MultiLine is a range of automatic lubrication systems designed for self-install on e.g. trucks, trailers, agricultural or compact earthmoving machinery and light industrial applications. It enables the use of automatic lubrication on applications where return on investment is challenging.

The MultiLine kits are ready to be installed by your own technicians. You can select a reservoir of 1.25 and 2 liter. With all of the greasing points lubricated automatically, the service interval and lifetime of the application are extended significantly. This makes the MultiLine AC a smart investment in operational efficiency.

- Suitable for oil SAE 80/90 up to NLGI-2 grease
- Designed for self-install
 - All components in a box
 - All fittings are standard with push-fit connectors
 - Lines are numbered
 - Lines are pre-cut and grouped
- Reduces operational costs and increases efficiency
- Waterproof and corrosion resistant



Ready to install kit

The pre-loomed kit contains all the necessary items: injectors, tubing, connectors and adapters for complete installation. A layout drawing is supplied for easy installation.

Approximately about one hour is needed to install pump and 15 minutes per lubrication point.

The ready-to-install kits ensure a quick installation and problem-free operation.

System overview - MultiLine AC



Fill cap

The MultiLine oil pumps are fitted with a bulk fill cap which is suitable for oil fill.

Reservoir with paddle blade

The reservoir is equipped with a paddle blade which pushes the lubricant into the pumping chamber and provides a visual indication of the pumps operation.

Available in 1.25 or 2 litre reservoir.

Pumping elements

MultiLine AC is available with up to 60 pumping elements. The MultiLine AC pumps are pre-calibrated with yellow 0.025 cc pumping units.

If a lubrication distribution line is not required simply remove the line and replace it with a blanking plug.

Filler coupling

At the bottom, the pump is equipped with a grease nipple for filling with grease. Using the grease nipple adaptor for grease fill avoids the possibility of air entrapment and cavitation.

Push fit connectors

The MultiLine AC pumps are pre-loomed from the pumping elements. The push fit connectors provide an easy installation of the lubrication lines.

The MultiLine AC pumps are used in many mobile applications with the motors being specified as 12V or 24V.

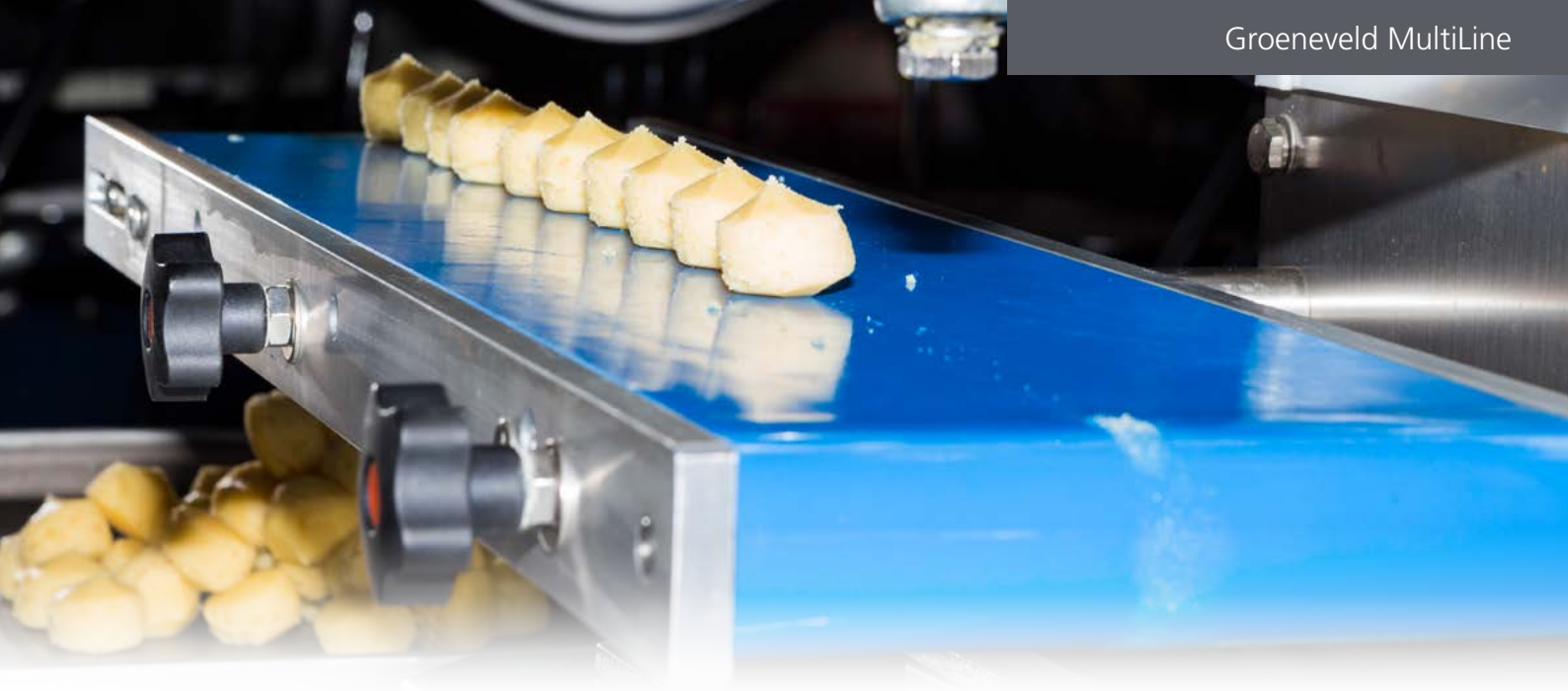

System overview MultiLine AXL



Fill cap

The MultiLine oil pumps are fitted with a bulk fill cap which is suitable for oil fill.

Reservoir with paddle blade

The reservoir is equipped with a paddle blade which pushes the lubricant into the pumping chamber and provides a visual indication of the pumps operation.

Available in 1.25 or 2 litre reservoir.

Pumping elements

The MultiLine pumps are pre-calibrated with blue 0.04 cc pumping units. A selection of pumping units with varying outputs are available to suit almost every need.

If a lubrication distribution line is not required simply remove the line and replace it with a blanking plug.

Filler coupling

At the bottom, the pump is equipped with a grease nipple for filling with grease. Using the grease nipple adaptor for grease fill avoids the possibility of air entrapment and cavitation.

Push fit connectors

The MultiLine AXL pumps are pre-loomed from the pumping element to the bulkhead connections on the pump bracket. The push fit connectors provide an easy installation of the lubrication lines.

The MultiLine AXL pumps are used in many industrial applications with the motors being specified as 110V or 220V.

Applications

The MultiLine range can be used for a wide variety of applications. The MultiLine AC is most commonly used for mobile applications like trucks, trailers, busses and agricultural applications. The MultiLine AXL is more suitable for industrial applications.

MultiLine AC



Trucks & Trailers



Bus & Coach



Balers



Light industry

MultiLine AXL



Pumping elements

A selection of pumping elements with varying outputs are available to suit almost any need. Each pumping element has a push fit connector to provide an easy installation of the lubrication lines.

The maximum output pressure of each pump element is 120 bar (1740 PSI).

Color	Output/stroke	Outlet size
Red	0.010 cc	4 mm OD Push type
Green	0.015 cc	
Yellow	0.025 cc	
Blue	0.040 cc	
Grey	0.060 cc	
Black	0.100 cc	

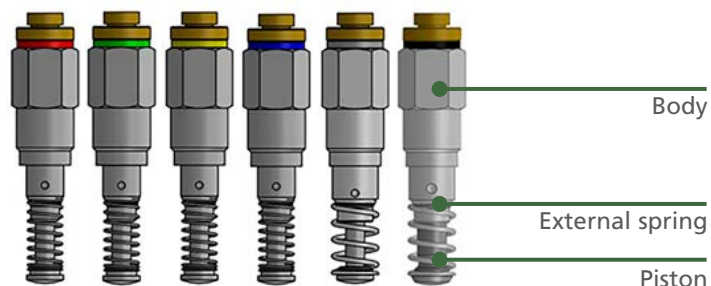

Technical information

Pump type	Electrical
Operating voltage	MultiLine AC: 12V or 24V MultiLine AXL: 110V or 220V
Maximum operating pressure	120 bar (1740 psi, 12 MPa)
Grease class	Oil SAE 80/90 to NLGI-2 greases
Reservoir capacity	1.25 or 2 litre
Minimum operation temperature	-23 °C (10 °F) with Greenlube NLGI-0-grease -13 °C (9 °F) with Greenlube NLGI-2 grease Based on maximum lubricant distribution line length of 10m (32ft)
Maximum operation temperature	60 °C (140 °F)
Protection class	IP66

*Nominal at 20 °C (68 °F) and 15W40 oil

BEKA AZU

The chain lubrication system



BEKA AZU & AZU-L

Drive chains are subject to a very high wear and tear. They need intensive care to reduce replacement rates. BEKA's AZU and AZU-L chain lubrication systems considerably improve the lifetime of drive chains and even protect the environment.

Conventional chain lubrication systems have one big disadvantage: in most cases, the lubricant is applied while the chains are standing still. Besides that, the metering of the lubricant is not very precise in many cases. Some parts of the chains receive far too much lubricant while others stay dry. Constant over-lubrication will lead to lubricant leakage and dripping.

The BEKA AZU operating principle is different from the conventional chain lubrication systems. The chains are supplied steadily with very small oil quantities while they are running and nothing drips off.

The AZU has not only economic, but also ecologic advantages: it increases the lifetime of drive chains and protects the environment.

The advantages:

- Compact design and therefore just a little mounting space needed
- Robust pump with long lifetime and low operating costs
- Available with mechanical, hydraulic or electrical drive and therefore suitable for many applications
- Up to 12 outlets with pairwise adjustable output
- The pump can be delivered completely pre-assembled according to customer specifications with predefined lines and line lengths (plug and play)
- Retrofitting kits in OE-quality

System overview

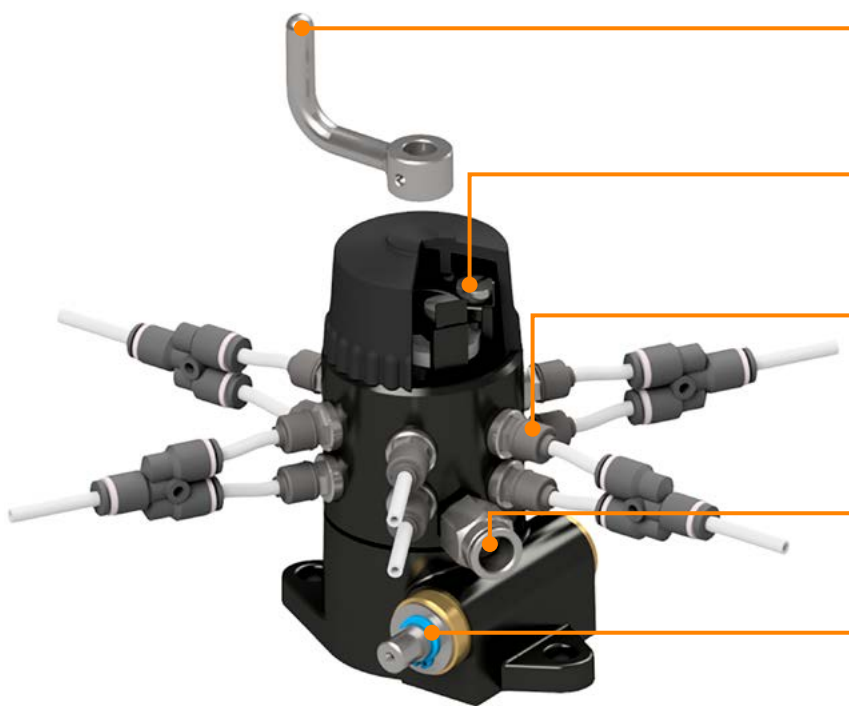

Hand crank

The device can be equipped with a hand crank for prefilling long lines with lubricant before the device starts up

Set screws for output rate

The piston stroke, and with that the output rate, can be adjusted with the set screw in the delivery piston (underneath the cap)

Outlets

The pump can be configured with up to 12 outlets with different hose connection types.

Push to fit connectors provide an easy installation of the lubrication lines.

Oil inlet

The oil inlet is connected to an oil container via a hose. Different oil container sizes are available.

Drive shaft

The drive shaft puts the centrally positioned pump shaft and the cam disk with a gear into a rotating movement. This carries out the strokes of the delivery pistons.

Applications

The BEKA AZU range can be used for a wide variety of applications in the agricultural sector, on port equipment and industry or recycling equipment.



Balers



Spreaders



Industry & Recycling

Operation principle

Lubrication takes place only when the machine is running. The drive shaft puts the centrally positioned AZU pump in motion. During the suction stroke oil is being taken from an external oil reservoir on the machine, which is being pumped to the lubrication points with the following piston stroke. The lubricant is applied onto the chains via brushes or felts and nothing drips off.

The AZU system provides up to 12 oil brushes with one pump. The feed rate of the different lubrication points can be adjusted individually with the set screws in the delivery position.

System specifications

No. of outlets	Max. 12
Output rate	Max. 0.06 cc per stroke and outlet
Regulation of output	1 - 6 individual outlets, 7 - 12 outlets in pairs
Driving speed to reduction	Max. 90 RPM at 3:1 Max. 200 RPM at 8,25:1 Max. 400 RPM at 16,66:1 Max. 600 RPM at 25:1 Max. 1300 RPM at 50:1
Operating pressure AZU	Max. 10 bar (145 psi)
Operating pressure AZU-L	Max. 5 bar (72.5 psi)
Suction height	Max. 500 mm
Lubricant	Oil
Viscosity range	25 - 1500 mm ² /s
Temperature range	Medium: 0 up to 70 °C (32 up to 161.6 °F) Ambient: 0 up to 40 °C (32 up to 104 °F)
Outlet type	Solderless pipe Ø 4 or 6 mm, or Ring piece for soldering in pipe Ø 4 or 6 mm
Suction connection	Ø 6, 8, or 10 mm
Sense of rotation	Optional
Drive	Rotating

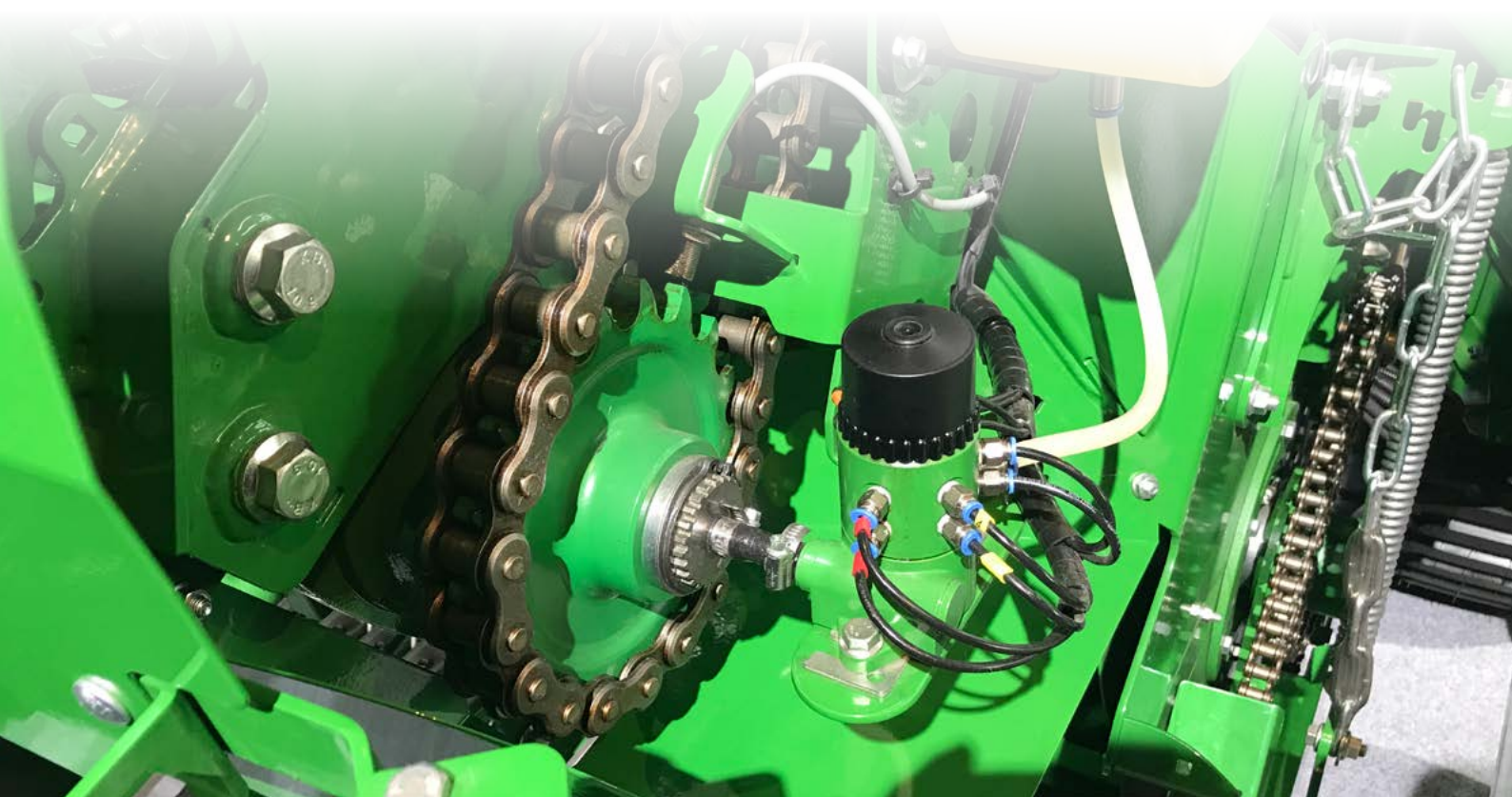



Groeneveld-BEKA | info@groeneveld-beka.com | www.groeneveld-beka.com

Despite every effort on our part, deviations from the illustrations or dimensions, calculation errors, printing errors or incomplete information in this brochure cannot be excluded. Groeneveld-BEKA accepts no liabilities for any inaccuracies and/or incompleteness in the content of the brochure. It is not permitted to continue to distribute the information published in this brochure without prior written permission from Groeneveld-BEKA, provided it is for personal use and solely for the purpose for which the information has been made available.