



KTR-STOP[®] Brake Systems

The efficient high-power brake

Made for Motion



www.ktr.com



We move the world: KTR

Competence meets creativity

As a leading manufacturer of high-quality drive and brake components as well as hydraulic components, KTR supplies mechanical couplings, clamping sets, torque limiters, measuring systems, hydraulic components and high-power brakes all over the world. With more than 50 years experience in power transmission we are trendsetters in the development of coupling technology and offer customised solutions to all industries. The KTR trademark characterises quality and innovation, speed, reliability, flexibility and a close working relationship with customers.

Having started with the curved-tooth gear coupling BoWex® and the torsionally flexible jaw coupling ROTEX®, KTR has built up an extensive product portfolio covering torques from 0,1 up to 1.000.000 Nm. The production by KTR's in-house, up-to-date machinery ensures that the couplings are made to the utmost accuracy. The couplings having a unit weight of up to 2 tons or more. Flexible automation ensures a quick and low-cost production even if the product has to be customised to meet customers individual specifications. KTR produce several million couplings a year.

Even though KTR's standard product portfolio is quite extensive, it only represents a fraction of the different options available. KTR is not only a subcontractor but also a solution provider. The knowledge gained from thousands of applications in the field allows us to find optimum, low-cost solutions for customised applications. We will consult you during the planning stage providing drawings and prototypes or arranging for local discussions if required. Every year KTR produces more than 10.000 new products ordered by customers. This trend increases year on year. This leads to many special products becoming standard items: We permanently give vital ideas to the Power Transmission technology – in cooperation with our customers.

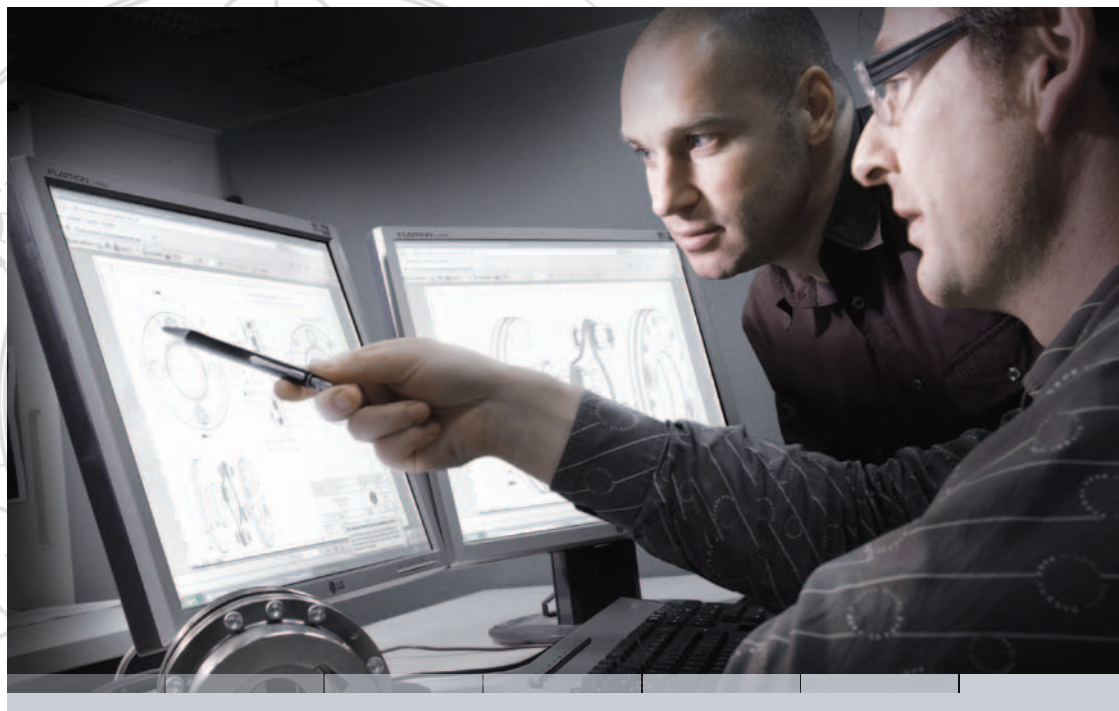

Accuracy meets speed

KTR products are evidence of well-designed, quality components resulting in improved characteristics of the drive or brake system and as a consequence, a longer service life of machines. It is our aim to continually improve the quality of our products and services. We can analyse the stiffness of components by utilising FEM (Finite Element Method) system and we can also perform torsional vibration calculations for entire drive systems. In our in-house Research and Development Centre we test our products on accurate test benches in realistic operating conditions. Our main objective is to provide you with the uppermost satisfaction.

Our technical sales engineers and our well-trained sales staff will be pleased to give you advice. KTR provides you with extensive services online, too: At www.ktr.com you can request information, including our product catalogue, 3D-CAD-models and assembly instructions. For standard applications you can select your drive component from of more than 3.500 standard products. Having selected which one is the right component for your application by using our online calculation program, you are now in a position to order the products by contacting your nearest KTR company. Alternatively our KTR Shop is open 24 hours a day.

Our latest scheduling system SAP ERP ensures an optimum networking with our customers and allows for a quick and reliable delivery service. A selection of 3.500 couplings and hydraulic components are permanently available from stock. For orders placed by 2:00pm we guarantee the despatch of orders the same day! In the KTR Logistics Centre the overall flow of goods is supervised by radio-controlled barcode scanning. Leading distribution partners ensure delivery on time. Our tracking and tracing system allows you to follow the progress of your order at all times. KTR supplies to every location in the world.

For further details about us and our products:
www.ktr.com

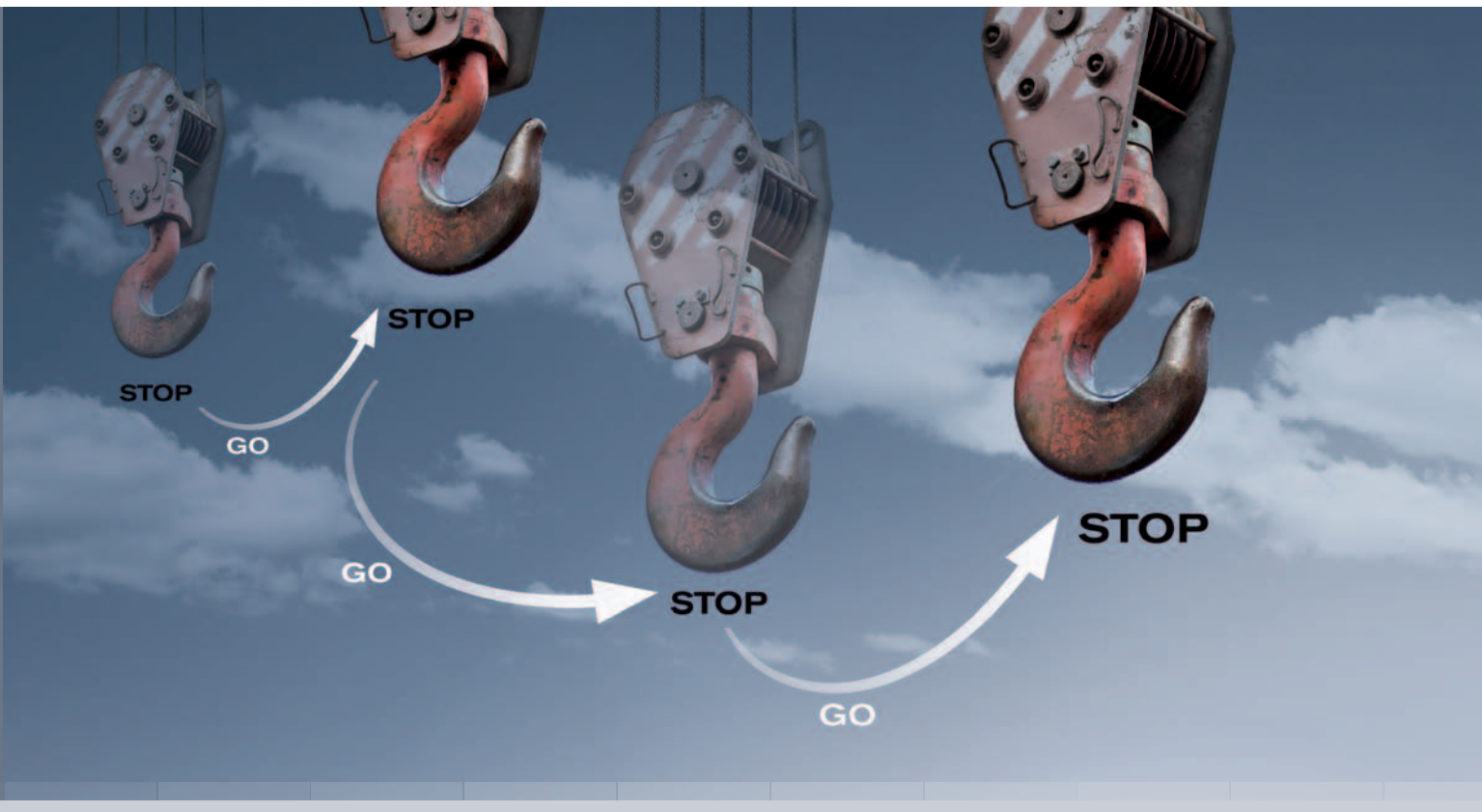

STOP and GO – with KTR

You will probably know that you can help move your business with KTR. We are mainly known for our drive components, it is less known that you can effectively apply the brakes with us as well. Why not simply make a stopover to get to know the new KTR-STOP® brake systems!

Revolution instead of evolution

For several years KTR have successfully distributed brakes in many countries throughout the world. Now we have combined this know-how about brakes with our experience, gained over decades, in drive technology which we are actually investigating in detail now. During a careful stop-and-go analysis our brakes were examined “disc by disc”. The materials were optimised, the processing was brought to perfection, the dimensions were reduced. Potential weak points were systematically eliminated, strengths of the product were consistently extended. The result is one of the most efficient and resistant brake systems you will find in the market at the moment. In other words: We have re-invented the brake!



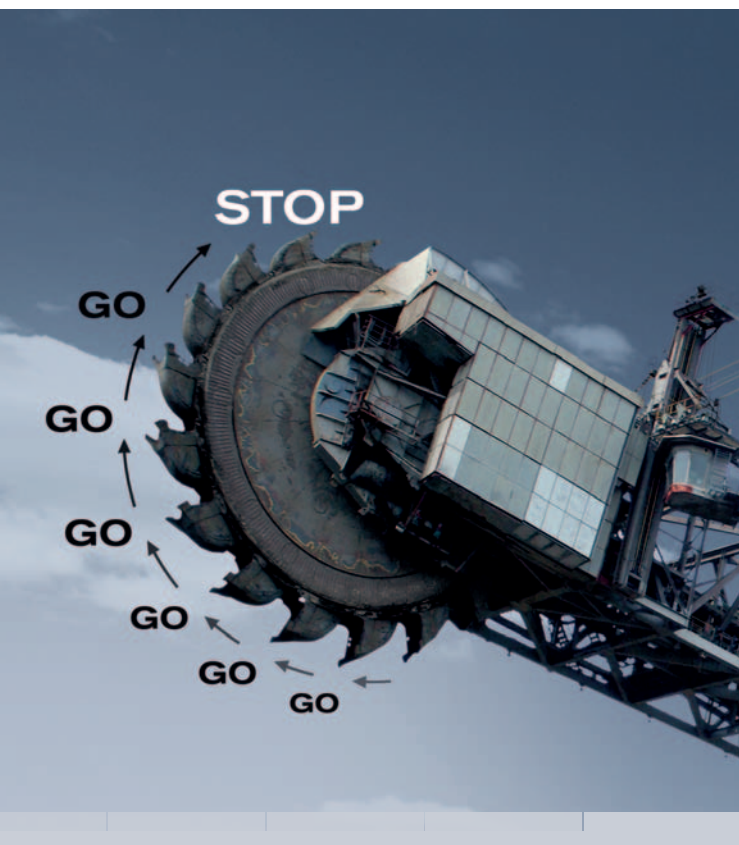

Benefits that take effect

It goes without saying that we have reverted to well-approved standards with the new development. The new KTR-STOP® brake systems are based on the conventional disc brake, but was improved significantly in many respects, for example:

- Higher protection against atmospheric influences by full encapsulation and integrated dirt strippers
- Less maintenance intervals and low operating expenses
- Longer service life
- Less wear due to additional guiding systems
- Higher power density by lower weight and more compact design
- Maximum utilisation of material of brake pads: They can be worn down to the base plate.

Higher variety of applications

Though different in their basic arrangement, the new KTR-STOP® brakes are equipped for different applications. Above all they are not afraid of heavy labour under aggressive and rough environmental conditions, which means they are ideal for mining as well as crane and wind power stations.

Think globally, brake locally

We combine designing standards well-approved throughout the world with your individual demands and requests on applications with everything we build. To make sure that you have a short braking distance, you will find our subsidiary companies and dealers throughout the world.

Simply consult with your local KTR partner – we will cope with your challenge with our united brake forces!



Accelerate your business – With the new KTR-STOP® brake systems

No matter whether your business is driven by harsh wind, gigantic lifting forces or irrepressible torque: With the new KTR-STOP® brake systems you will safely brake even heavy machinery under tough environmental conditions. Offshore and onshore. On the surface and underground. Today and tomorrow.

The right brake for every application

KTR offers the perfect brake solution for every purpose – from 1 to 500 kN, in a hydraulic or spring-actuated design. The brake forces are as variable as the applications: The variety includes crane building, mining and conveyor technology, wind power stations and mill building to marine and offshore technology. On land we safely brake belt conveyors, bucket wheel excavators, reclaimers or stackers. On the high seas we brake winches, anchor windlasses and deck cranes. In addition, we can stop large wind turbines via azimuth and rotor lock brakes.

Full lifting and conveying force

In mining and crane building as well as conveyor and marine technology not only high forces, but also adverse environmental influences have to be considered. The new KTR-STOP® brake systems were developed particularly for the use under the most extreme environmental conditions. Mud, rain, salt, severe cold and blistering heat had to be considered when deciding on our materials of choice, we improved the corrosion protection, refined the selection. Having learned the hard way our brakes are well-prepared for offshore applications in a salty atmosphere. Just as reliably they withstand the aggressive environmental conditions in mining and crane building, in particular the heavy load of heat caused by foundry cranes or the sulphurous air in copper mining. In brief: KTR-STOP® still brakes when other brakes already have put a spanner in the works or become prone to fading by insufficient heat dissipation.





Full wind power

Brakes are a decisive component of the safety concept of wind power stations. Or better: two decisive components. Since they are used on two pivots: on the rotor and the pod. We recommend KTR-STOP® high-power brakes for both applications.

KTR-STOP® rotor brakes

In older times wind turbines were often designed according to the stall principle ensuring a power limitation on the rotor blades by selective stall. In this case the brakes serving as emergency brake calliper actually had to bear the total load so that they had to be selected properly. Today modern wind turbines often go with the flow by making use of the wind's brake effect. They operate almost exclusively according to the pitch principle, i. e. active blade angle by rotating the rotor blades (pitching). In this case the rotor brakes actually serve as a secondary safety element as well as stop brakes for maintenance operations and standstill periods. In an average wind turbines usually two brake callipers with a disc diameter of about 1 m and closing pressure of approx. 100 kN are sufficient.

KTR-STOP® yaw brakes

In contrast to that KTR-STOP® brake systems display their full strength as yaw brakes for aligning and locking the turbine in the wind. The permanent change between "STOP and GO" requests for particularly low-wear components with gigantic locking pressure of up to 500 kN per brake in order to protect the turbine against wind gust and dynamic load permanently. On large turbines above one megawatt, sometimes up to ten active disc brake callipers having such power are used. With KTR-STOP® you are always on the safe side – even if the wind changes.

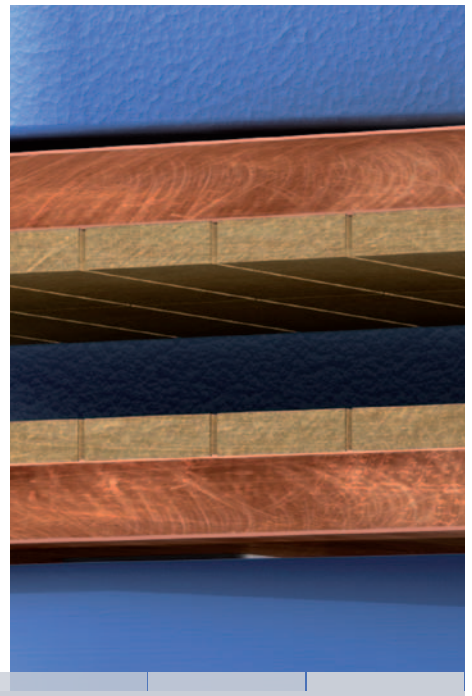
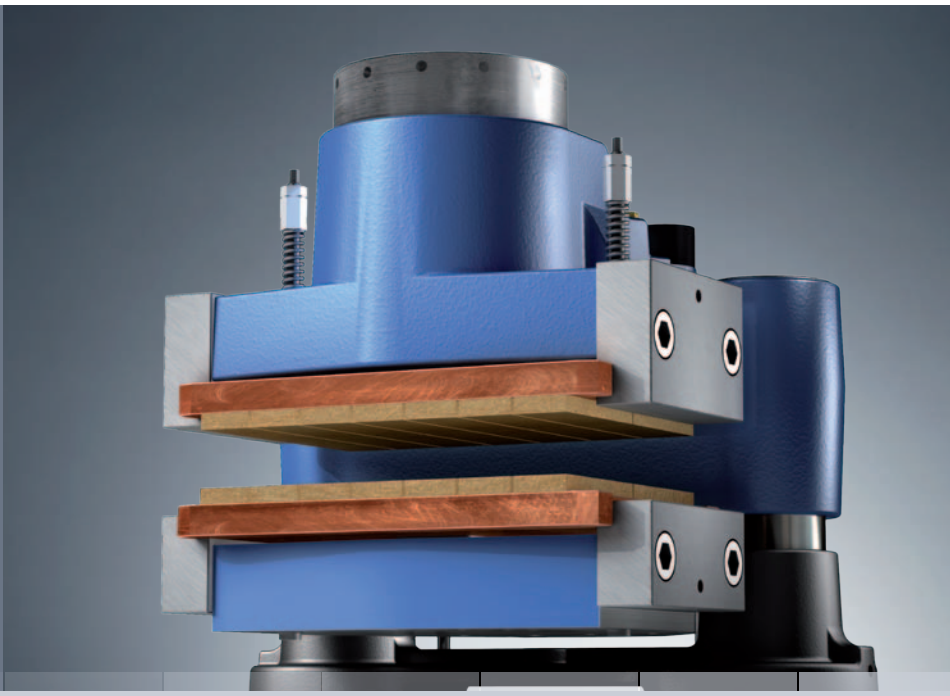

Compact. Powerful. Uncompromising: Your benefits at a glance

The new KTR-STOP® brake systems are recognisable by their high power density, low weight and optimised wear behaviour. In this way the operating expenses are reduced and the service life is increased. These are benefits which already pay off with the design – which is continued non-braked during operation.

More compact design – higher power density

There is one design criteria in KTR: We make all components as compact as possible to leave you the maximum space. The same applies for our new brake systems. Their design with optimised dimensions makes it possible for a high power with low weight. The compact dimensions extend the application range while at the same time reducing the transport, storage and mounting costs.

Better pads – less wear

In addition, a special design ensures considerably longer service life of the pad sets. Material, processing and arrangement were optimised in a way that the brake pads can be worn almost down to the base plate. The pads of other manufacturers often have to be replaced much earlier. In contrast to that KTR-STOP® ensures maximum utilisation of material without reduction of power. This means: less standstill periods, less maintenance expenses and lower operating costs.



„IntelliRamp“

Perfect “environmental protection” by full encapsulation

For KTR environmental protection means two things: We not only protect the environment against wear materials, but we also protect our products against negative environmental influences. This is achieved by the new KTR-STOP® brake systems by a number of path breaking innovations, mainly with the full encapsulation of the brake. Thus, mechanical environmental influences and aggressive media cannot do any harm to the inner life of the brake. Almost fully covered shafts, additional wear rings and integrated dirt wipers ensure a considerably lower level of failure and consequently a significantly longer service life.

Brake powerfully – control intelligently

Brake power means nothing without control. That is why we can provide with our brakes the intelligent brake control “IntelliRamp®”, if requested. It allows for controlled and coordinated brake processes which you can accurately adjust to your parameters. By entering “permanent brake speed” sudden brake processes, as an example, which might be dangerous are prevented. Entering “permanent brake period” stops all systems at the same time, in this way preventing, as an example, a critical material jam in conveyor systems.

Entering “invariable deceleration” adjusts the brake power continuously, preventing unnecessary wear of material. Moreover, IntelliRamp® has a return stop in case of overload as well as an excessive speed control. For further details please have a look at page 28 and 29.

Our offer! – Your requests?

KTR-STOP® brakes are available as designs S(small) and M(medium) and L(large) at the moment. Further sizes (XS, XL und XXL) are already being developed and will supplement the range soon. The offer will be completed by suitable hydraulic power packs.

We will be pleased to select your individual brake system as well – combined with all benefits of KTR-STOP®.

Simply let us know what you need – it is hard for us to brake our enthusiasm about developing!

Summary of clamping forces



Brake types	Clamping forces [kN]													
	0	50	100	150	200	250	300	350	400	450	500	550	600	
YAW M 	[Bar chart showing clamping force range from 0 to 200 kN]													
YAW L 	[Bar chart showing clamping force range from 0 to 550 kN]													
S-A-F 	[Bar chart showing clamping force range from 0 to 50 kN]													
M-A-F 	[Bar chart showing clamping force range from 0 to 150 kN]													
S-xx-F 	[Bar chart showing clamping force range from 0 to 50 kN]													
M-xxx-F 	[Bar chart showing clamping force range from 0 to 200 kN]													
L-xxx 	[Bar chart showing clamping force range from 0 to 350 kN]													

Table of contents



KTR STOP®	
YAW Brake	
YAW M	12
YAW L	14
KTR STOP®	
Floating calliper brake (hydraulically applied)	
S-A-F	16
M-A-F	18
KTR STOP®	
Floating calliper brake (spring applied)	
S-xx-F	20
M-xxx-F	22
KTR STOP®	
Fixed calliper brake (spring applied)	
L-xxx	24
KTR STOP® RL	
Rotor Lock	
S	26
M	27
IntelliRamp®	
Electronic Brake Control	
Product description	28

KTR-STOP® YAW M

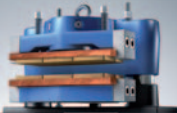
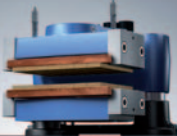
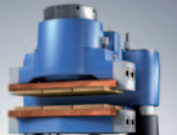
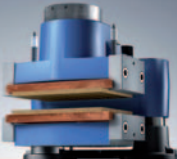
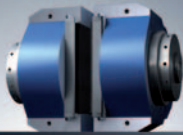
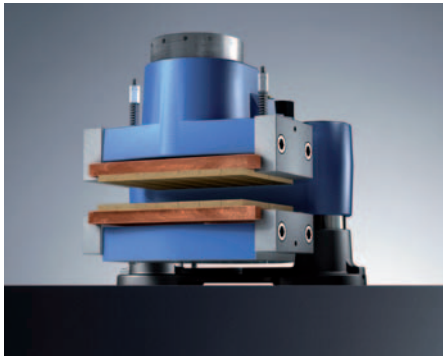
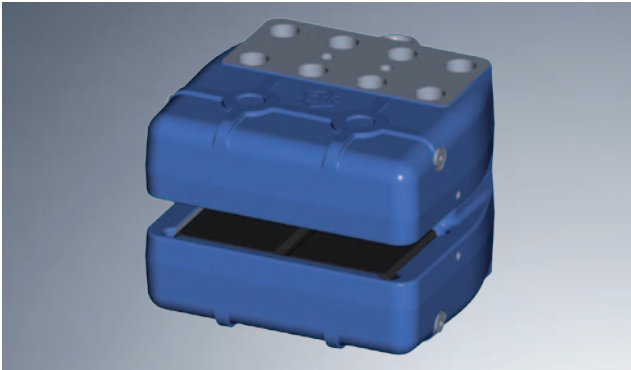

- Short reaction periods subject to the short distance between brake pad and brake disc as well as the low oil volume
- Big pad surface resulting in small surface pressure, low wear of pads and low temperature
- Low maintenance expenses because of a few mobile components only
- Drain ports avoid leakages on the brake pad
- Brake pads available from various materials
- Easy replacement of brake pads
- Suitable for rough ambient conditions

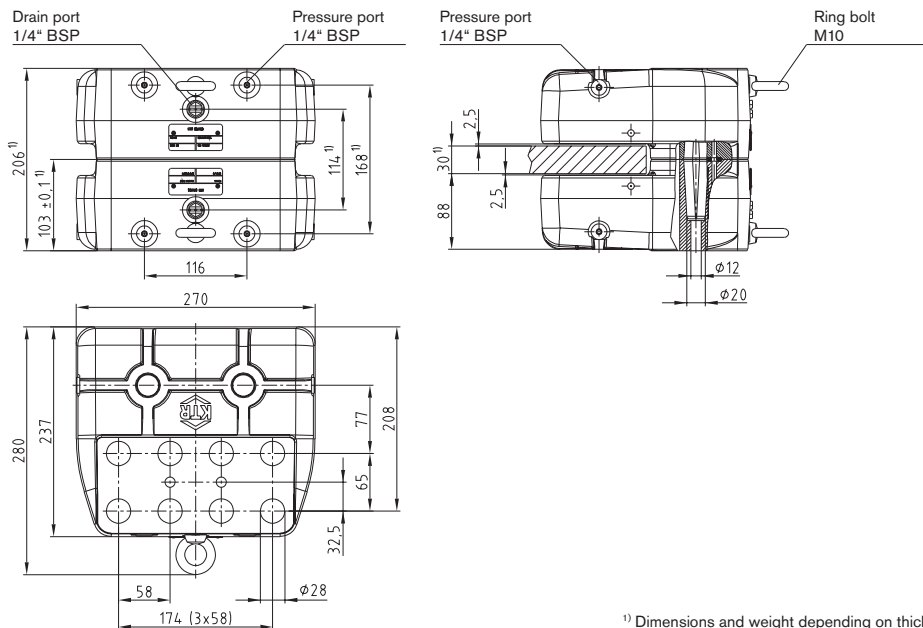

¹⁾ Dimensions and weight depending on thickness of brake disc.

KTR-STOP® YAW M			
Total weight	Approx. 63 kg ¹⁾	Max. clamping force	203 kN
Width of brake pad	108 mm	Max. operating pressure (up to $\mu = 0,4$)	160 bar
Surface area of each brake pad	20.300 mm ²	Thickness of brake disc	20 mm - 70 mm
Max. wear of each brake pad	7 mm (material: organic)	Assembly of outside brake	400 mm
Nominal coefficient of friction ²⁾	$\mu = 0,4$	Min. diameter of brake disc $\varnothing D_A$	900 mm
Total brake piston area - complete brake	254 cm ²	Assembly of inside brake	900 mm
Volume at 1 mm stroke - complete brake	25,4 cm ³	Min. diameter of brake disc $\varnothing D_I$	-30 °C to +40 °C
Pressure port	1/4" BSP	Operating temperature	
Drain port	1/4" BSP		

²⁾ The friction coefficient each depends on the application or material of the friction pad; please consult with KTR.

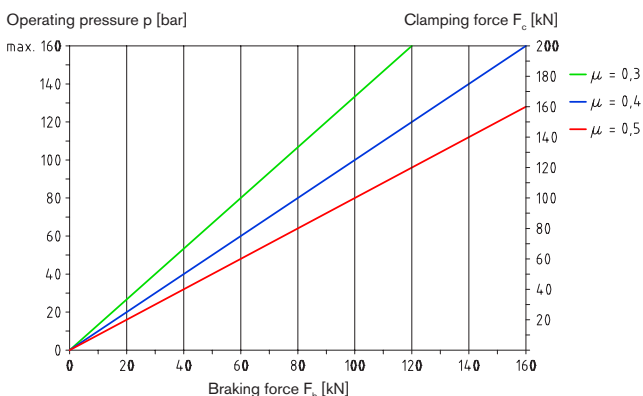

$$F_b = F_c \cdot 2 \cdot \mu$$

$$M_b = z \cdot F_b \cdot \frac{D_{av}}{2}$$

- F_b = Braking force [kN]
 F_c = Clamping force [kN]
 M_b = Braking torque [kNm]
 z = Number of brakes
 D_{av} = Effective diameter of brake [m]

Order form:

KTR-STOP®	YAW M	A	-	30
KTR Brake	Brake size	Variation		Thickness of brake disc

KTR-STOP® YAW M

Assembly of inside brake

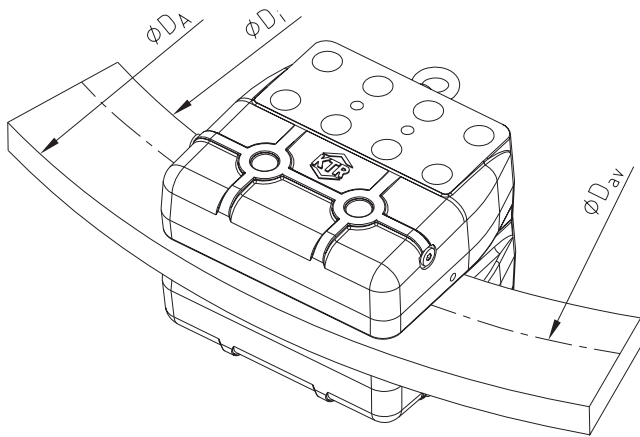

Calculation of brake disc

$$D_{i \min.} = \sqrt{D_{av}^2 - 200 \cdot D_{av} + 46000}$$

$$D_{av} = \sqrt{D_i^2 - 36000} + 100$$

$$D_{A \min.} = D_i + 250$$

Assembly of outside brake

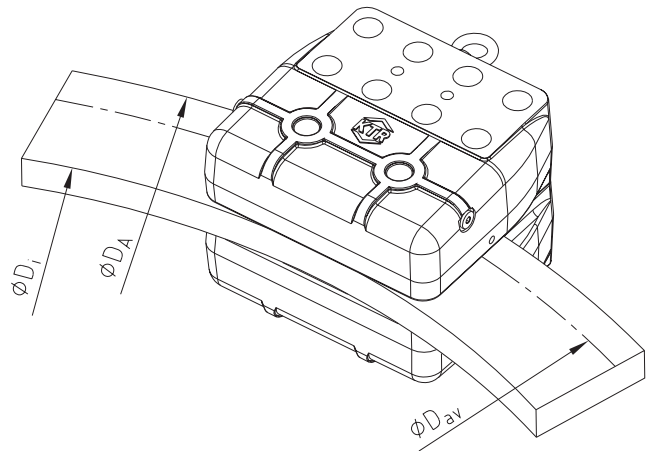

Calculation of brake disc

$$D_{av} = D_A - 102$$

$$D_{i \max.} = D_A - 240$$

Brake assembly dimensions

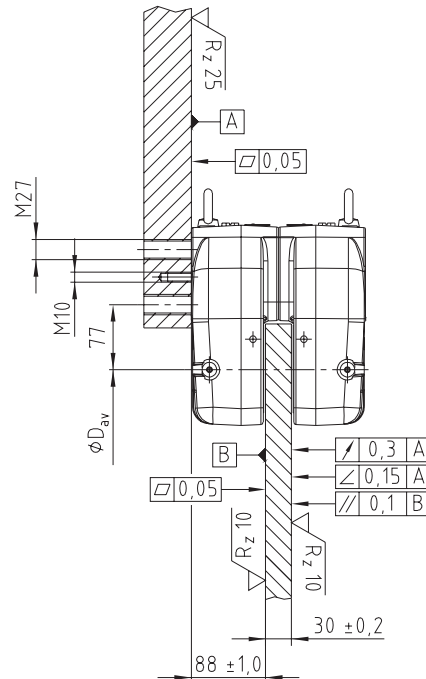
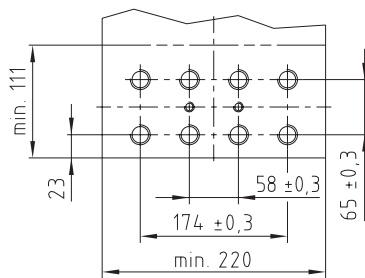

Optional

- Different colours available
- Sensor indicating wear of pads and state
- Temperature sensor
- Alternative brake pad materials

KTR-STOP® YAW L

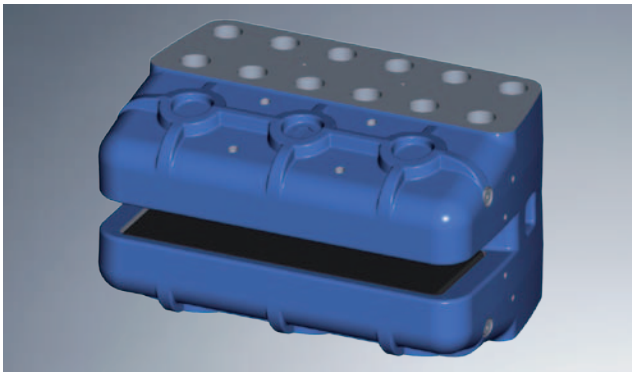

- Short reaction periods subject to the short distance between brake pad and brake disc as well as the low oil volume
- Big pad surface resulting in small surface pressure, low wear of pads and low temperature
- Low maintenance expenses because of a few mobile components only
- Drain ports avoid leakages on the brake pad
- Brake pads available from various materials
- Easy replacement of brake pads
- Suitable for rough ambient conditions

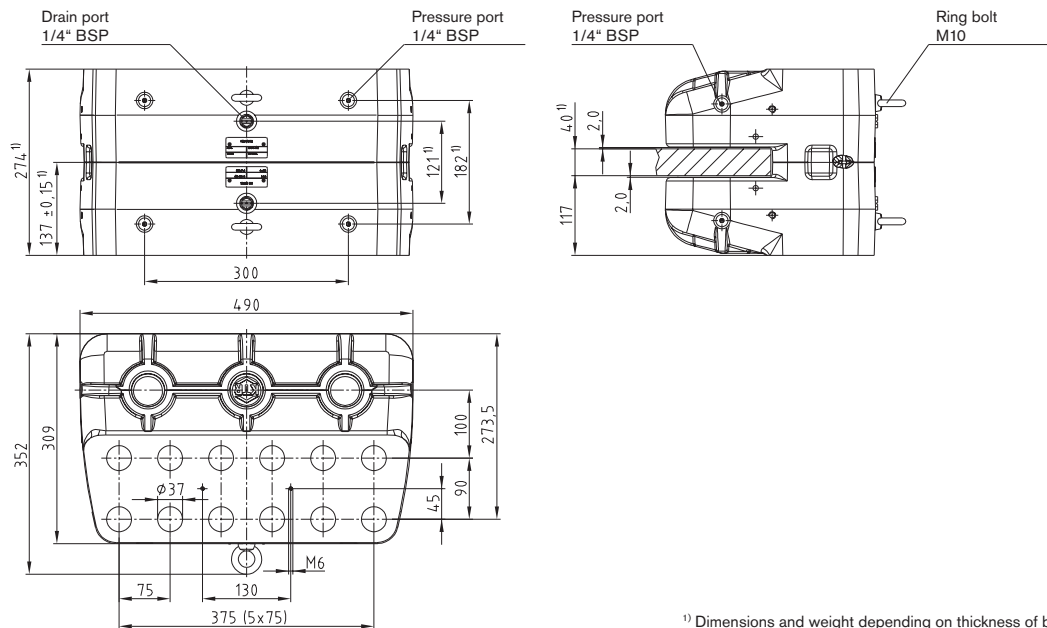

¹⁾ Dimensions and weight depending on thickness of brake disc.

KTR-STOP® YAW L			
Total weight	Approx. 176 kg ¹⁾	Max. clamping force	542 kN
Width of brake pad	138 mm	Max. operating pressure (up to $\mu = 0,4$)	160 bar
Surface area of each brake pad	58.000 mm ²	Thickness of brake disc	40 mm - 60 mm
Max. wear of each brake pad	7 mm (material: organic)	Assembly of outside brake	2000 mm
Nominal coefficient of friction ²⁾	$\mu = 0,4$	Min. diameter of brake disc $\varnothing D_A$	2500 mm
Total brake piston area - complete brake	678 cm ²	Assembly of inside brake	2500 mm
Volume at 1 mm stroke - complete brake	67,8 cm ³	Min. diameter of brake disc $\varnothing D_I$	-30 °C to +40 °C
Pressure port	1/4" BSP	Operating temperature	
Drain port	1/4" BSP		

²⁾ The friction coefficient each depends on the application or material of the friction pad; please consult with KTR.

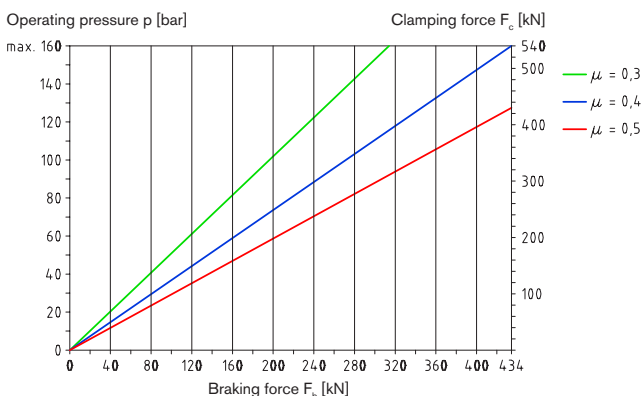

$$F_b = F_c \cdot 2 \cdot \mu$$

$$M_b = z \cdot F_b \cdot \frac{D_{av}}{2}$$

- F_b = Braking force [kN]
 F_c = Clamping force [kN]
 M_b = Braking torque [kNm]
 z = Number of brakes
 D_{av} = Effective diameter of brake [m]

Order form:

KTR-STOP®	YAW L	A	-	40
KTR Brake	Brake size	Variation		Thickness of brake disc

KTR-STOP® YAW L

Assembly of inside brake

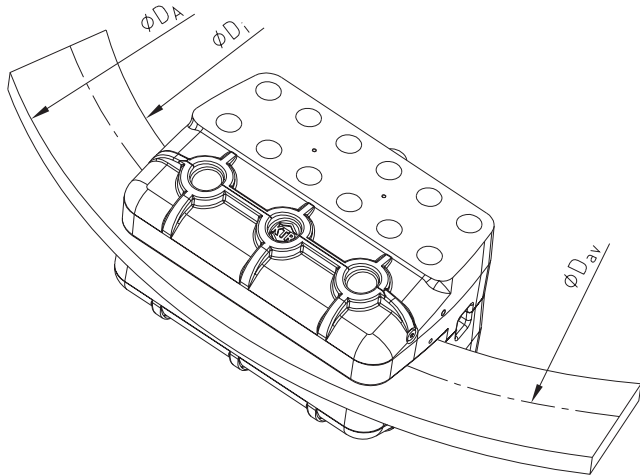

Calculation of brake disc

$$D_{i \min.} = \sqrt{D_{av}^2 - 270 \cdot D_{av} + 200000}$$

$$D_{av} = \sqrt{D_i^2 - 180000} + 135$$

$$D_{A \min.} = D_i + 320$$

Assembly of outside brake

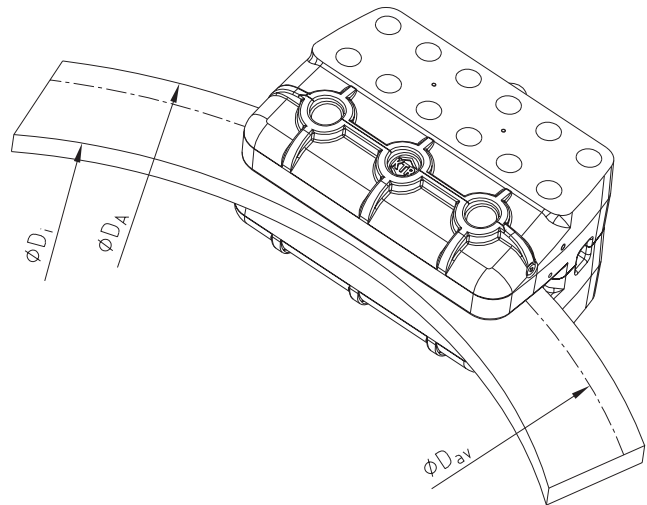

Calculation of brake disc

$$D_{av} = D_A - 136$$

$$D_{i \max.} = D_A - 320$$

Brake assembly dimensions

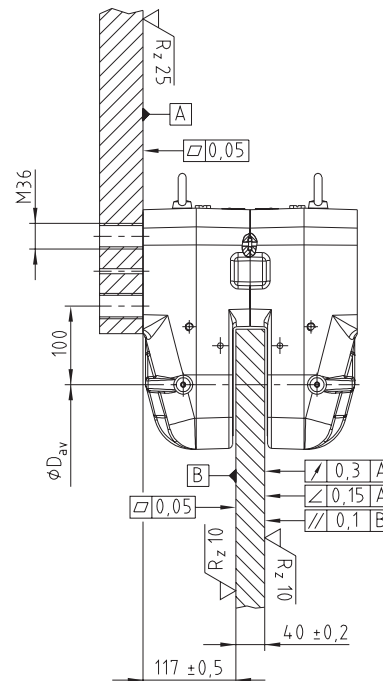
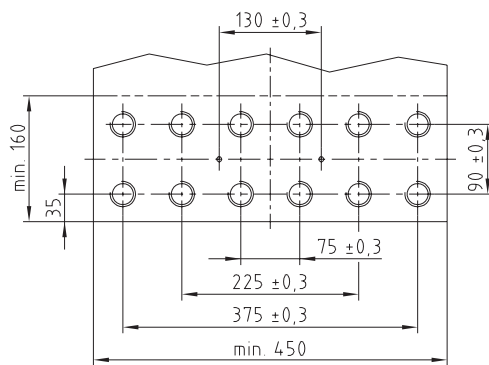

Optional

- Different colours available
- Sensor indicating wear of pads and state
- Temperature sensor
- Alternative brake pad materials

KTR-STOP® S-A-F

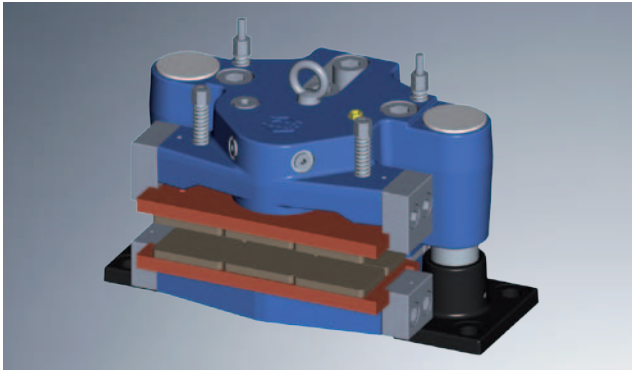

- Short reaction periods subject to the short distance between brake pad and brake disc as well as the low oil volume
- Big pad surface resulting in small surface pressure, low wear of pads and low temperature
- Low maintenance expenses because of a few mobile components only
- Drain ports avoid leakages on the brake pad
- Brake pads available from various materials
- Easy replacement of brake pads
- Suitable for rough ambient conditions

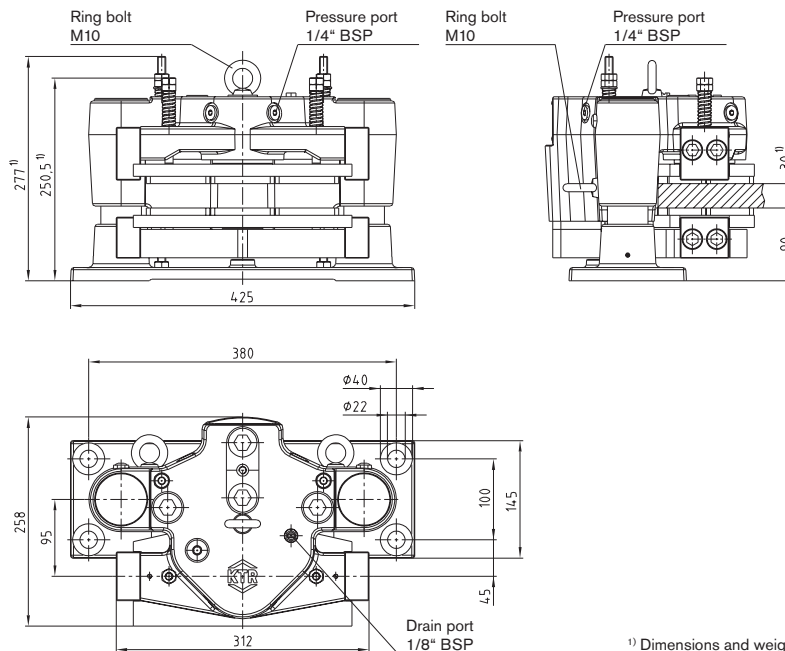

¹⁾ Dimensions and weight depending on thickness of brake disc.

KTR-STOP® S-A-F				
Total weight		Approx. 76 kg ¹⁾	Max. clamping force	55 kN
Width of brake pad		125 mm	Max. operating pressure	125 bar
Surface area of each brake pad	organic	28.700 mm ²	Thickness of brake disc	20 mm - 40 mm
	sintered	26.800 mm ²	Pressure port	1/4" BSP
Max. wear of each brake pad		7 mm	Drain port	1/8" BSP
Nominal coefficient of friction ²⁾		$\mu = 0,4$	Floating range on axles - towards mounting surface	5 mm
Total brake piston area - complete brake		44,2 cm ²	Floating range on axles - away from mounting surface	10 mm
Volume at 1 mm stroke - complete brake		4,42 cm ³	Min. diameter of brake disc $\varnothing D_A$	500 mm
			Operating temperature	-30 °C to +40 °C

²⁾ The friction coefficient each depends on the application or material of the friction pad; please consult with KTR.

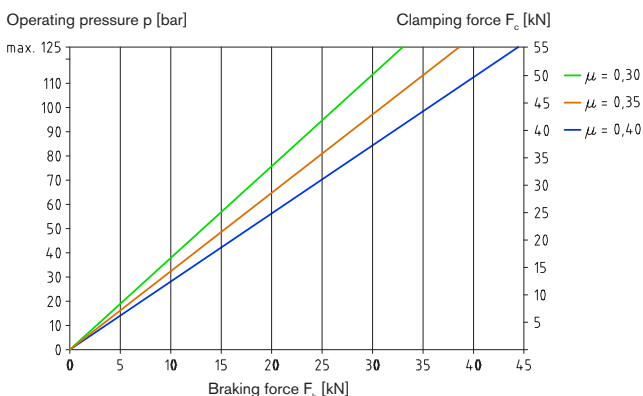

$$F_b = F_c \cdot 2 \cdot \mu$$

$$M_b = z \cdot F_b \cdot \frac{D_{av}}{2}$$

- F_b = Braking force [kN]
 F_c = Clamping force [kN]
 M_b = Braking torque [kNm]
 z = Number of brakes
 D_{av} = Effective diameter of brake [m]

Order form:

KTR-STOP®	S	-	A	-	F	A	-	30
KTR Brake	Brake size		Active		Floator	Variation		Thickness of brake disc

KTR-STOP® S-A-F

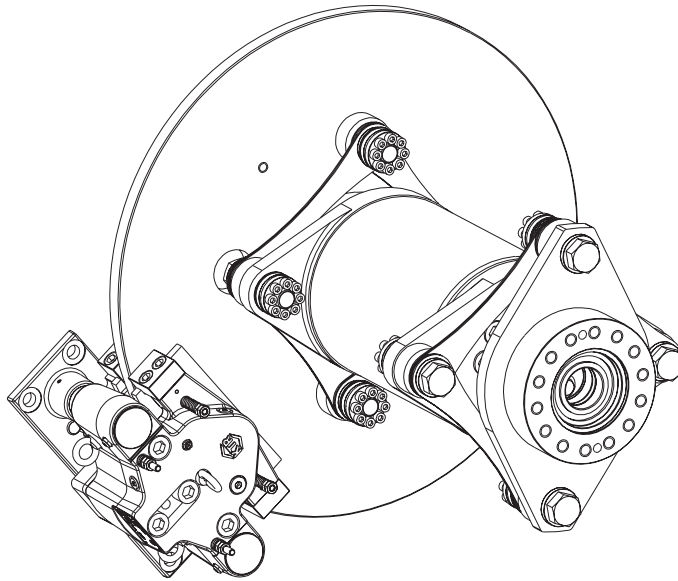

Calculation of brake disc

up to $\varnothing D_A = 1000$ mm

$$D_{C \max} = D_A - 260$$

$$D_{av} = D_A - 130$$

from $\varnothing D_A = 1000$ mm up to $\varnothing D_A = 1800$ mm

$$D_{C \max} = D_A - 250$$

$$D_{av} = D_A - 120$$

from $\varnothing D_A = 1800$ mm

$$D_{C \max} = D_A - 240$$

$$D_{av} = D_A - 110$$

Brake assembly dimensions

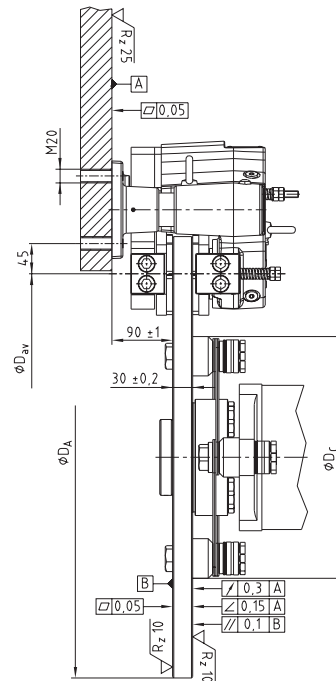
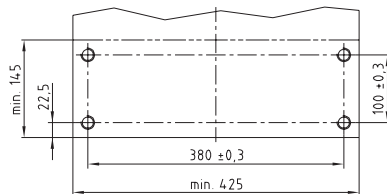

Optional

- Different colours available
- Sensor indicating wear of pads and state
- Temperature sensor
- Alternative brake pad materials

KTR-STOP® M-A-F

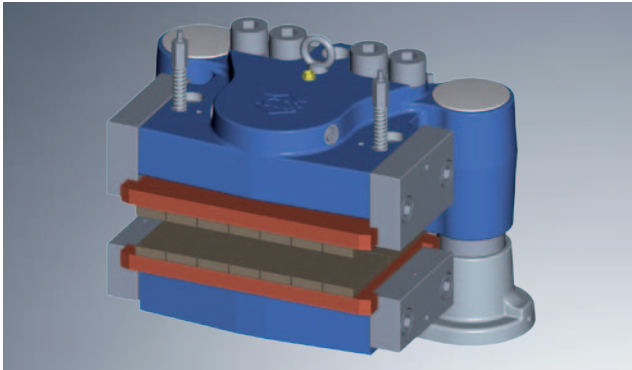

- Short reaction periods subject to the short distance between brake pad and brake disc as well as the low oil volume
- Big pad surface resulting in small surface pressure, low wear of pads and low temperature
- Low maintenance expenses because of a few mobile components only
- Drain ports avoid leakages on the brake pad
- Brake pads available from various materials
- Easy replacement of brake pads
- Suitable for rough ambient conditions
- Easy assembly of the brake by means of two screws

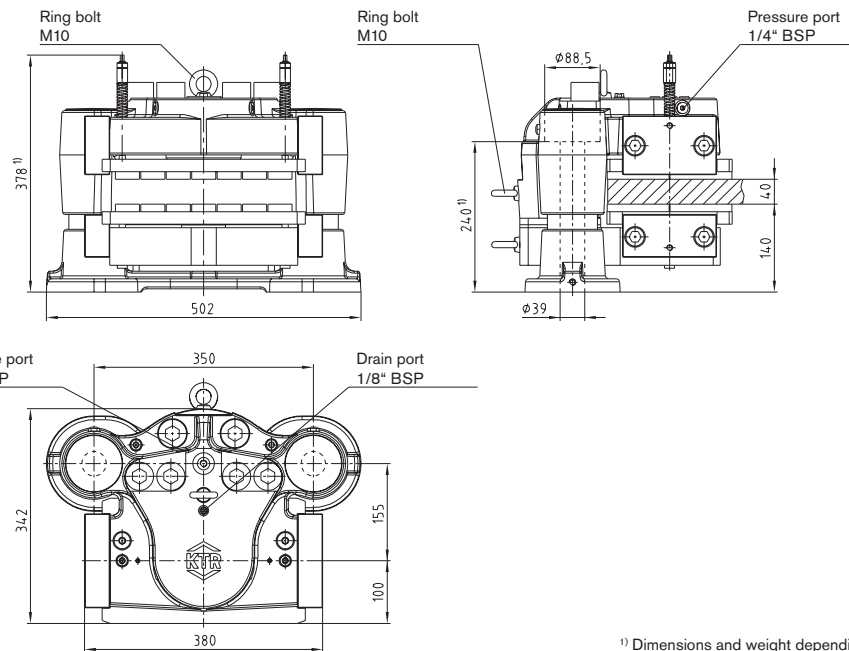

¹⁾ Dimensions and weight depending on thickness of brake disc.

KTR-STOP® M-A-F			
Total weight		Approx. 172 kg ¹⁾	Max. clamping force
Width of brake pad		200 mm	130 kN
Surface area of each brake pad	organic	57.900 mm ²	Max. operating pressure
	sintered	53.500 mm ²	115 bar
Max. wear of each brake pad		10 mm	Thickness of brake disc
			25 mm - 50 mm
Nominal coefficient of friction ²⁾		$\mu = 0,4$	Pressure port
Total brake piston area - complete brake		113 cm ²	Drain port
			1/8" BSP
Volume at 1 mm stroke - complete brake		11,3 cm ³	Floating range on axles - towards mounting surface
			5 mm
			Floating range on axles - away from mounting surface
			10 mm
			Min. diameter of brake disc $\varnothing D_A$
			800 mm
			Operating temperature
			-30 °C to +40 °C

²⁾ The friction coefficient each depends on the application or material of the friction pad; please consult with KTR.

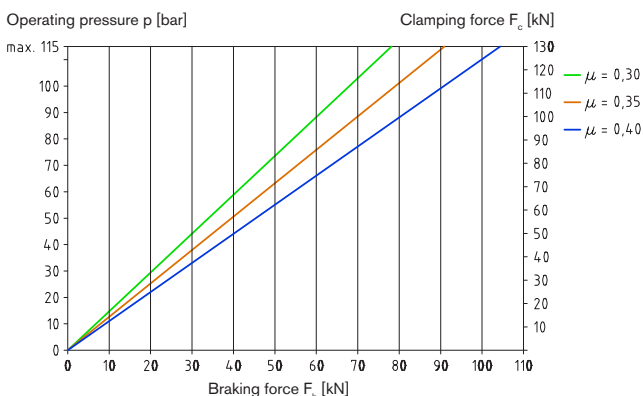

$$F_b = F_c \cdot 2 \cdot \mu$$

$$M_b = z \cdot F_b \cdot \frac{D_{av}}{2}$$

- F_b = Braking force [kN]
 F_c = Clamping force [kN]
 M_b = Braking torque [kNm]
 z = Number of brakes
 D_{av} = Effective diameter of brake [m]

Order form:

KTR-STOP®	M	-	A	-	F	A	-	40
KTR Brake	Brake size		Active		Floater	Variation		Thickness of brake disc

KTR-STOP® M-A-F

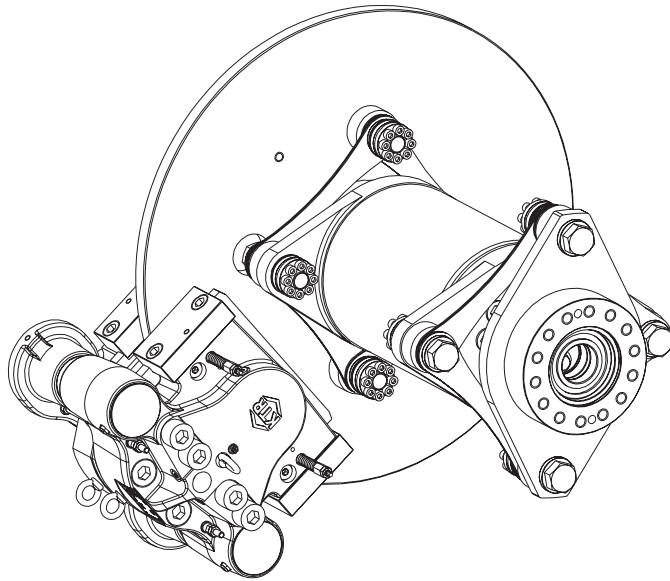

Calculation of brake disc

$$D_{C_{max}} = D_A - 410$$

$$D_{av} = D_A - 200$$

Brake assembly dimensions

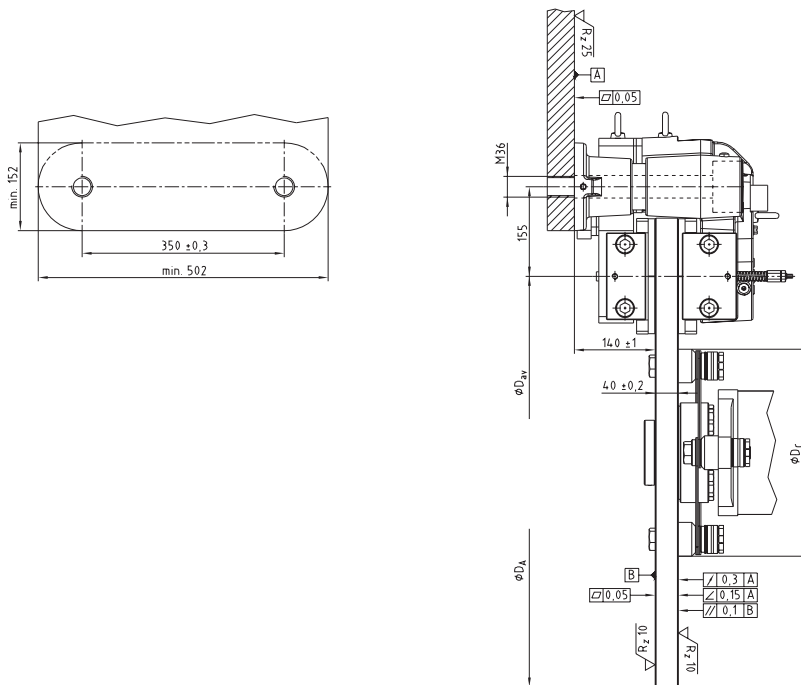

Optional

- Different colours available
- Sensor indicating wear of pads and state
- Temperature sensor
- Alternative brake pad materials

KTR-STOP® S-xx-F

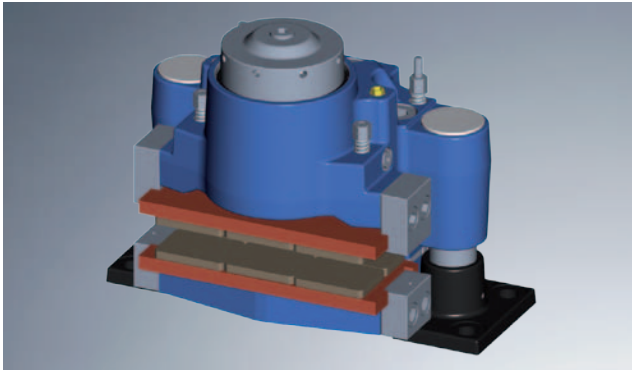

- Sealed shafts for difficult ambient conditions
- Big pad surface resulting in small surface pressure, low wear of pads and low temperature
- Low wear of pistons due to arrangement of the pistons in guide rings
- High power density
- Brake pads available from various materials
- Dirt is prevented by strippers in the shaft guidance

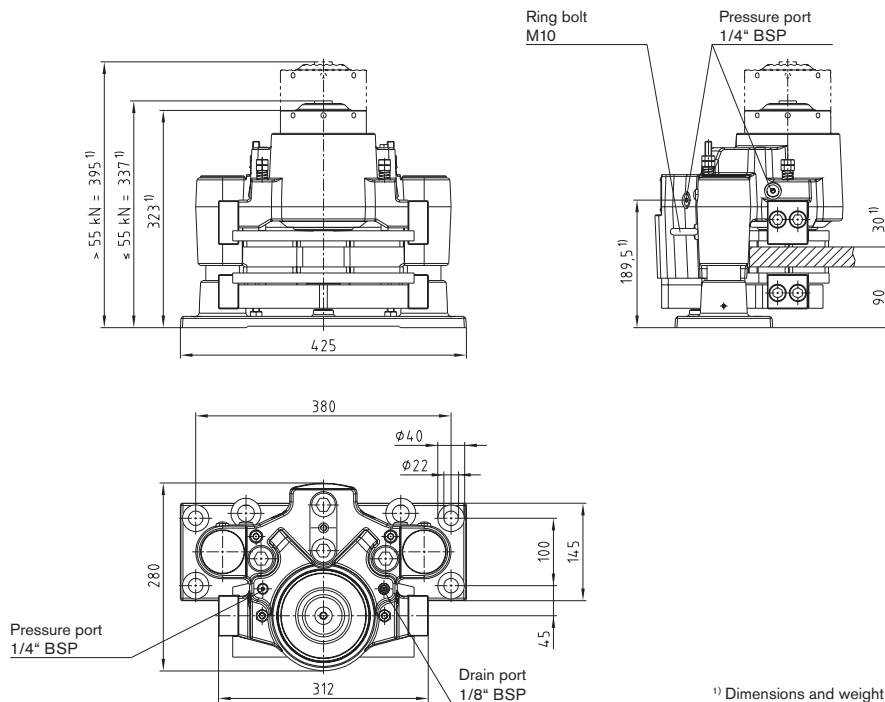

¹⁾ Dimensions and weight depending on thickness of brake disc.

KTR-STOP® S-xx-F			
Total weight	Approx. 90 kg - 99 kg ¹⁾		Max. operating pressure
Width of brake pad	125 mm	Thickness of brake disc	200 bar
Surface area of each brake pad	organic	28.700 mm ²	Pressure port
	sintered	26.800 mm ²	Drain port
Max. wear of each brake pad	7 mm	Floating range on axles - towards mounting surface	1/8" BSP
Nominal coefficient of friction ²⁾	μ = 0,4	Floating range on axles - away from mounting surface	5 mm
Total brake piston area - complete brake	69 cm ²	Min. diameter of brake disc Ø _A	10 mm
Volume at 1 mm stroke - complete brake	6,9 cm ³	Operating temperature	500 mm
			-30 °C to +40 °C

Brake types				
Brake type ³⁾	Clamping force F _c [kN]	Loss of force ⁴⁾ [%]	Opening pressure [bar]	Weight ¹⁾ [kg]
KTR-STOP® S-20-F	20	4,5	40	90
KTR-STOP® S-40-F	40	6,5	90	90
KTR-STOP® S-60-F	60	7,0	130	100
KTR-STOP® S-80-F	80	5,0	170	100

²⁾ The friction coefficient each depends on the application or material of the friction pad; please consult with KTR.

³⁾ Other types on request

⁴⁾ With a stroke of 1 mm (0,5 mm wear of pad on each side)

$$F_b = F_c \cdot 2 \cdot \mu$$

$$M_b = z \cdot F_b \cdot \frac{D_{av}}{2}$$

F_b = Braking force [kN]

F_c = Clamping force [kN]

M_b = Braking torque [kNm]

z = Number of brakes

D_{av} = Effective diameter of brake [m]

Order form:

KTR-STOP®	S	-	40	-	F	A	-	30
KTR Brake	Brake size		Clamping force		Floater	Variation		Thickness of brake disc

KTR-STOP® S-xx-F

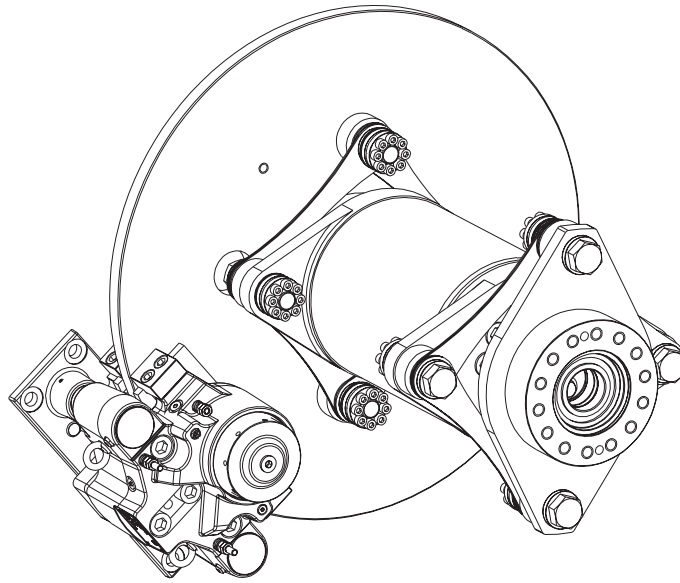

Calculation of brake disc

up to $\varnothing D_A = 1000$ mm

from $\varnothing D_A = 1000$ mm up to $\varnothing D_A = 1800$ mm

from $\varnothing D_A = 1800$ mm

$$D_{C \max} = D_A - 305$$

$$D_{C \max} = D_A - 295$$

$$D_{C \max} = D_A - 285$$

$$D_{av} = D_A - 130$$

$$D_{av} = D_A - 120$$

$$D_{av} = D_A - 110$$

Brake assembly dimensions

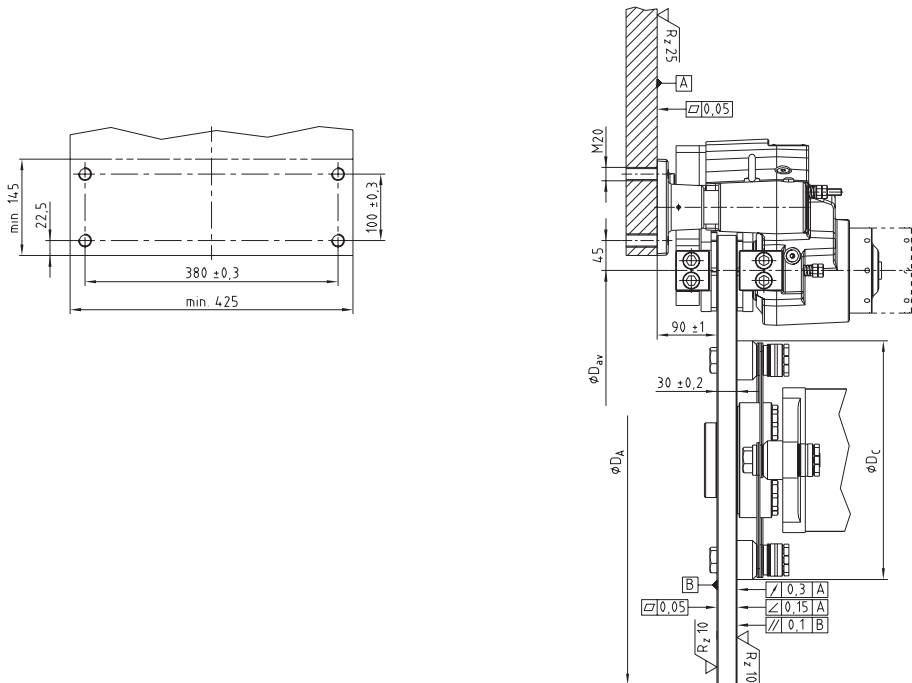

Optional

- Different colours available
- Sensor indicating wear of pads and state
- Temperature sensor
- Alternative brake pad materials

KTR-STOP® M-xxx-F

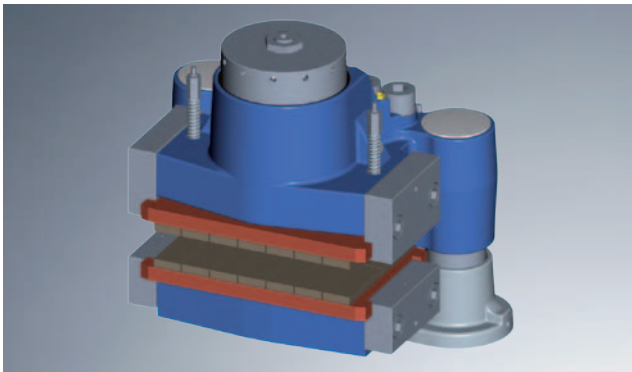

- Sealed shafts for difficult ambient conditions
- Big pad surface resulting in small surface pressure, low wear of pads and low temperature
- Low wear of pistons due to arrangement of the pistons in guide rings
- High power density
- Brake pads available from various materials
- Dirt is prevented by strippers in the shaft guidance
- Easy assembly of the brake by means of two screws

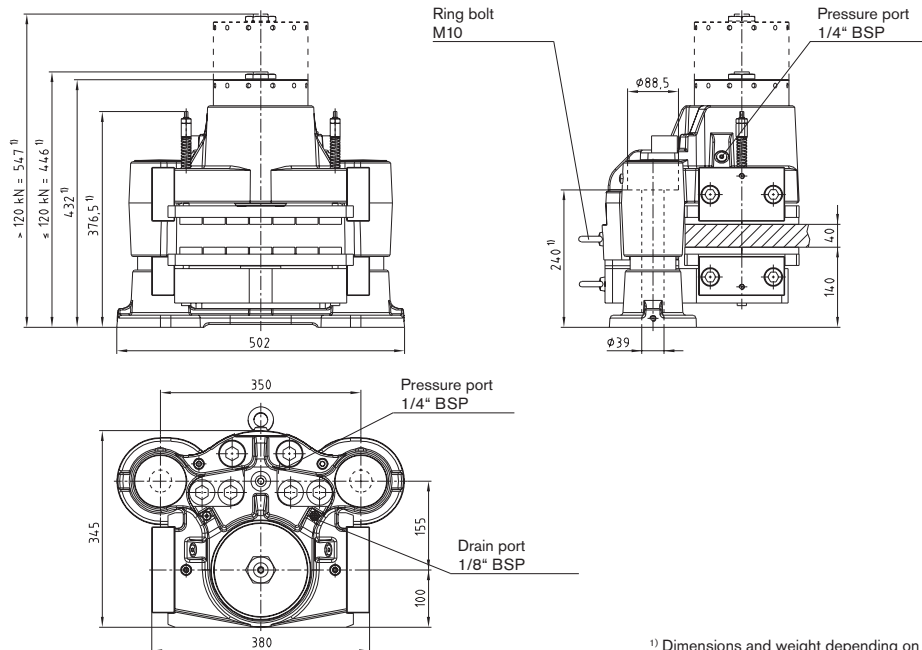

¹⁾ Dimensions and weight depending on thickness of brake disc.

KTR-STOP® M-xxx-F			
Total weight	Approx. 193 kg - 212 kg ¹⁾		Max. operating pressure
Width of brake pad	200 mm	Thickness of brake disc	25 mm - 50 mm
Surface area of each brake pad	organic	57.900 mm ²	Pressure port
	sintered	53.500 mm ²	Drain port
Max. wear of each brake pad	10 mm	Floating range on axles - towards mounting surface	5 mm
Nominal coefficient of friction ²⁾	μ = 0,4	Floating range on axles - away from mounting surface	below 120 kN = 10 mm from 120 kN = 5 mm
Total brake piston area - complete brake	137,4 cm ²	Min. diameter of brake disc Ø _{D_A}	800 mm
Volume at 1 mm stroke - complete brake	13,74 cm ³	Operating temperature	-30 °C to +40 °C

Brake types				
Brake type ³⁾	Clamping force F _c [kN]	Loss of force ⁴⁾ [%]	Opening pressure [bar]	Weight ¹⁾ [kg]
KTR-STOP® M-100-F	100	7,0	110	200
KTR-STOP® M-120-F	120	8,5	130	200
KTR-STOP® M-140-F	140	4,5	150	212
KTR-STOP® M-160-F	160	7,0	180	212
KTR-STOP® M-180-F	180	6,0	190	212

²⁾ The friction coefficient each depends on the application or material of the friction pad; please consult with KTR.

³⁾ Other types on request

⁴⁾ With a stroke of 1 mm (0,5 mm wear of pad on each side)

$$F_b = F_c \cdot 2 \cdot \mu$$

$$M_b = z \cdot F_b \cdot \frac{D_{av}}{2}$$

F_b = Braking force [kN]
F_c = Clamping force [kN]
M_b = Braking torque [kNm]

z = Number of brakes
D_{av} = Effective diameter of brake [m]

Order form:	KTR-STOP®	M	-	100	-	F	A	-	40
	KTR Brake	Brake size		Clamping force		Floater	Variation		Thickness of brake disc

KTR-STOP® M-xxx-F

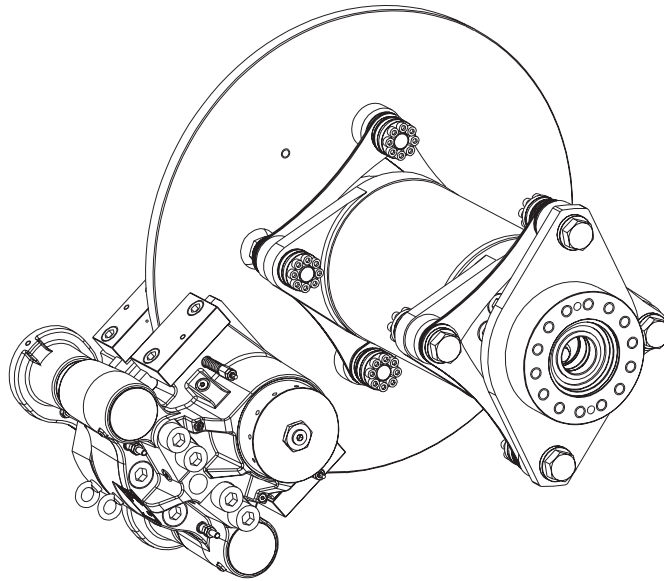

Calculation of brake disc

$$D_{C \max} = D_A - 410$$

$$D_{av} = D_A - 200$$

Brake assembly dimensions

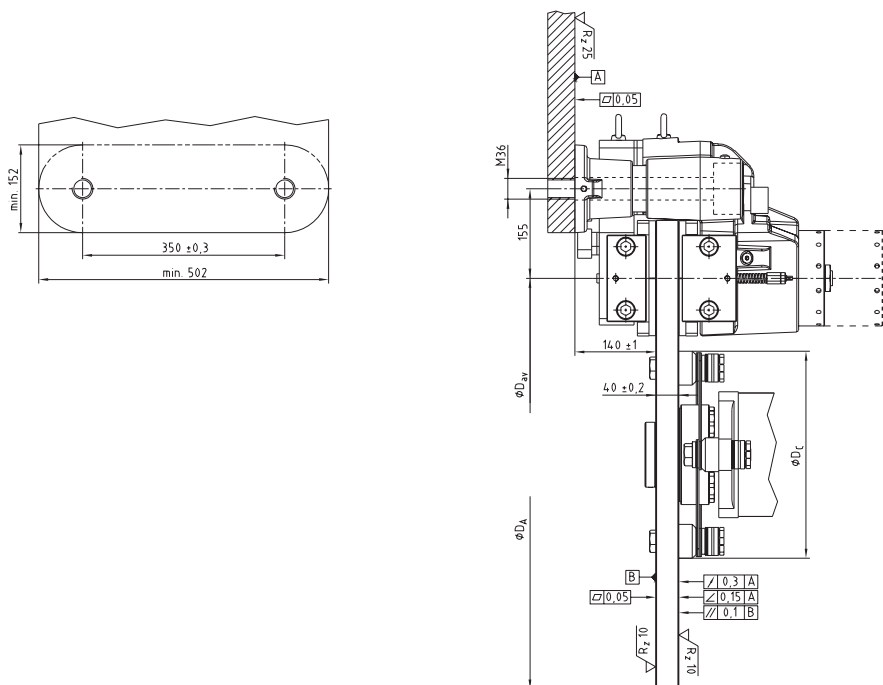

Optional

- Different colours available
- Sensor indicating wear of pads and state
- Temperature sensor
- Alternative brake pad materials

KTR-STOP® L-xxx

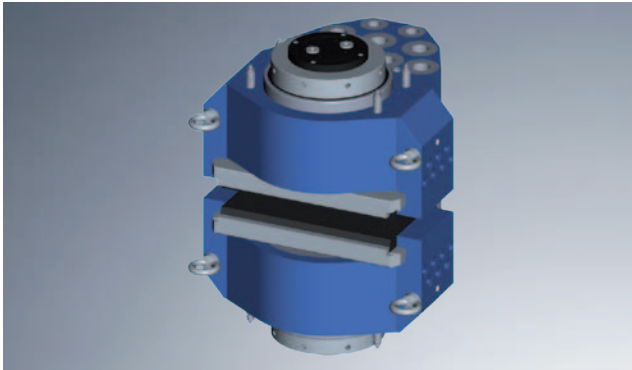

- Universal applications, since available both in arctic and offshore design
- Low maintenance costs due to the modular design and low wear of the piston surfaces subject to guide rings
- Reduced maintenance periods due to the quick adjustment under pressure by means of setting pins
- Continuous brake force due to a small power loss with wear of brake pads
- Easy assembly by means of mechanical clamping nuts
- Brake pads available from various materials

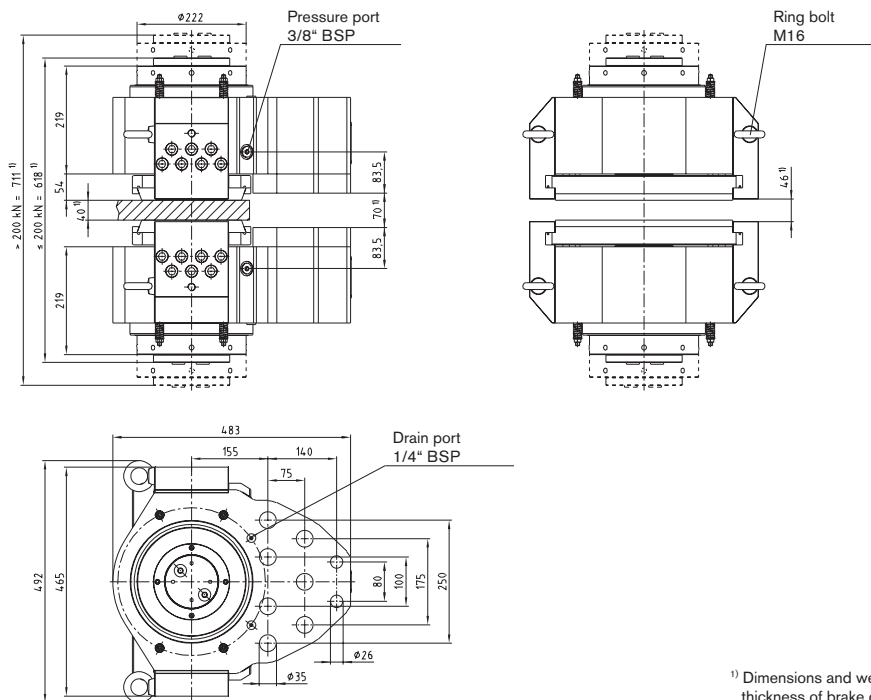

¹⁾ Dimensions and weight depending on the thickness of brake disc and base plate.

KTR-STOP® L			
Total weight	Approx. 470 kg - 500 kg ¹⁾	Max. clamping force	350 kN
Width of brake pad	240 mm	Max. operating pressure	200 bar
Surface area of each brake pad (organic/sintered)	72.900 mm ²	Thickness of brake disc	30 mm - 100 mm
Max. wear of each brake pad	12 mm	Pressure port	3/8" BSP
Nominal coefficient of friction ²⁾	$\mu = 0,4$	Drain port	1/4" BSP
Total brake piston area - complete brake	534 cm ²	Min. diameter of brake disc ϕD_A	800 mm
Volume at 1 mm stroke - complete brake	53,4 cm ³	Operating temperature	-30 °C to +40 °C

Brake types				
Brake type ³⁾	Clamping force F_c [kN]	Loss of force ⁴⁾ [%]	Opening pressure [bar]	Weight ¹⁾ [kg]
KTR-STOP® L-150	150	6,0	80	470
KTR-STOP® L-200	200	5,0	110	470
KTR-STOP® L-250	250	6,0	140	500
KTR-STOP® L-300	300	5,0	170	500
KTR-STOP® L-350	350	7,0	190	500

²⁾ The friction coefficient each depends on the application or material of the friction pad; please consult with KTR.

³⁾ Other types on request

⁴⁾ With a stroke of 1 mm (1 mm wear of pad on each side)

$$F_b = F_c \cdot 2 \cdot \mu$$

F_b = Braking force [kN]

z = Number of brakes

F_c = Clamping force [kN]

D_{av} = Effective diameter of brake [m]

M_b = Braking torque [kNm]

$$M_b = z \cdot F_b \cdot \frac{D_{av}}{2}$$

Order form:

KTR-STOP®	L	-	200	A	-	40	-	70
KTR Brake	Brake size		Clamping force	Variation		Thickness of brake disc		Thickness of base plate (stand)

KTR-STOP® L-xxx

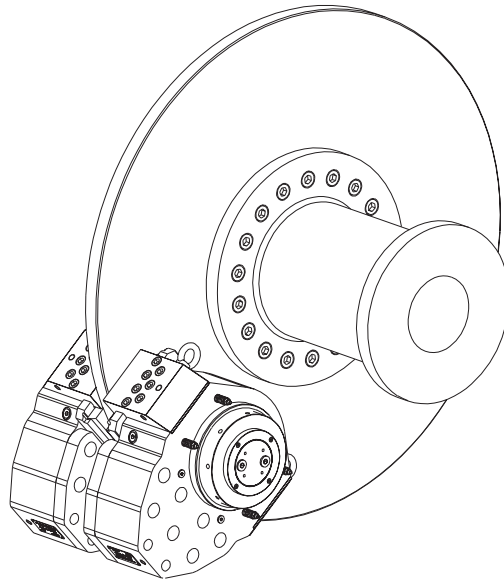

Calculation of brake disc

$$D_{C \max} = D_A - 570$$

$$D_{av} = D_A - 230$$

Brake assembly dimensions

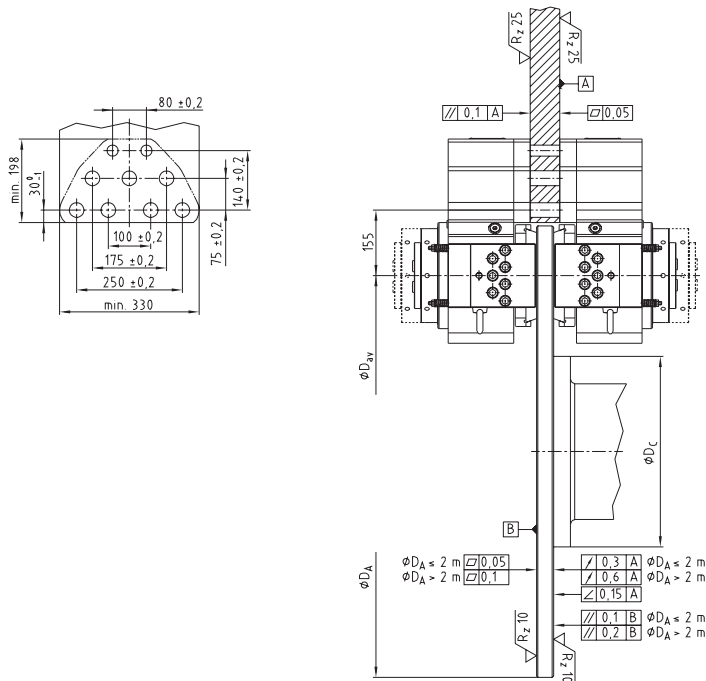

Optional

- Different colours available
- Sensor indicating wear of pads and state
- Temperature sensor
- Alternative brake pad materials

KTR-STOP® RL S

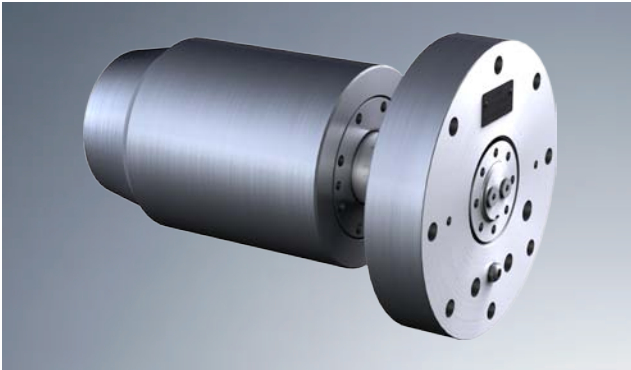

- Rotor Lock for wind turbines
- Locks the rotor on the shaft side with low speed
- Hydraulic and mechanical version available in two sizes
- Monitoring of locking operation via sensors

Hydraulic version

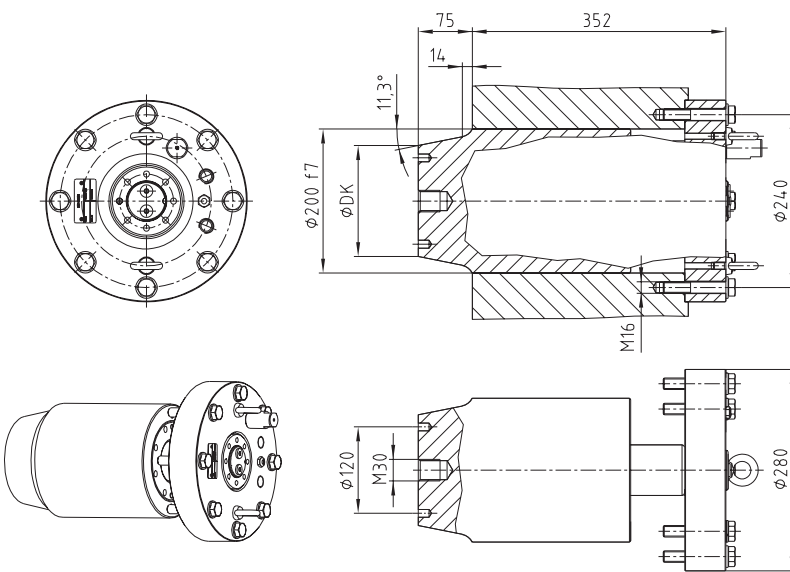

Mechanical version

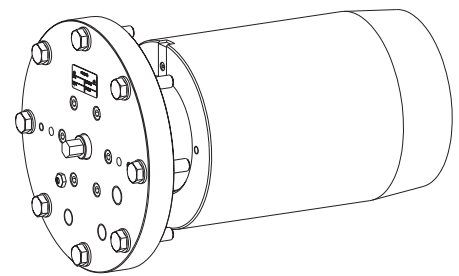

$$M_L = z \cdot F_L \cdot \frac{D_{\text{eff.}}}{2}$$

- F_L = Lateral force [kN]
 M_L = Lock torque [kNm]
 z = Number of Rotor Lock
 $D_{\text{eff.}}$ = Pitch circle diameter of locking disc [m]

KTR-STOP® RL S			
Weight	Approx. 90 kg	Piston diameter	120 mm
Max. stroke	80 mm	Piston area fore stroke	113,10 cm ²
Max. lateral force ¹⁾	2000 kN	Piston area back stroke	74,61 cm ²
Max. operating pressure	250 bar	Oil volume per 1 mm stroke	11,3 cm ³
Max. force fore stroke F+	283 kN	Oil volume with 75 mm stroke (full stroke)	848,2 cm ³
Max. force back stroke F-	187 kN	Pressure port	1/4" BSP

¹⁾ Please note that the lateral force refers to the Rotor Lock only.

Assembly dimension

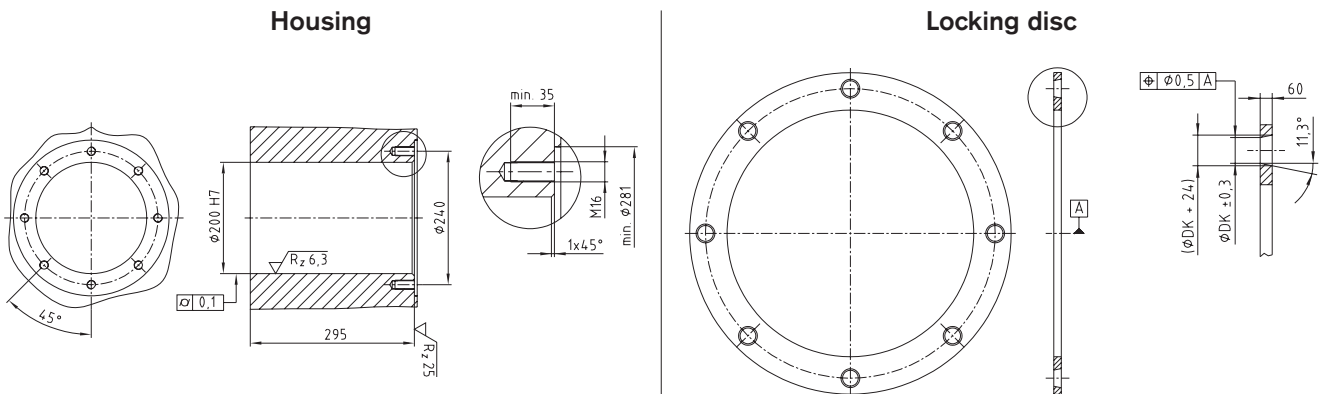

Order form:	KTR-STOP® RL	S	-	A	-	295
	KTR Rotor Lock	Rotor Lock size		Variation		Length of installation

KTR-STOP® RL M

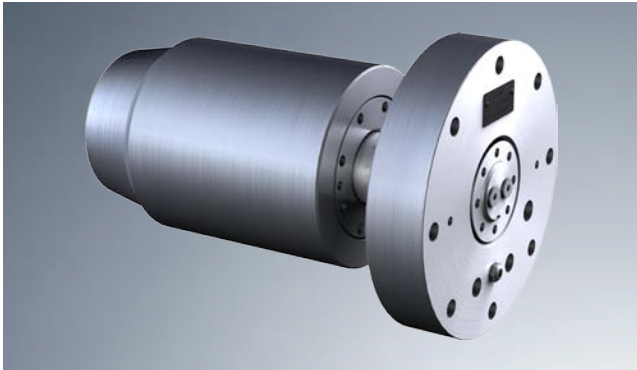

- Rotor Lock for wind turbines
- Locks the rotor on the shaft side with low speed
- Hydraulic and mechanical version available in two sizes
- Monitoring of locking operation via sensors

Hydraulic version

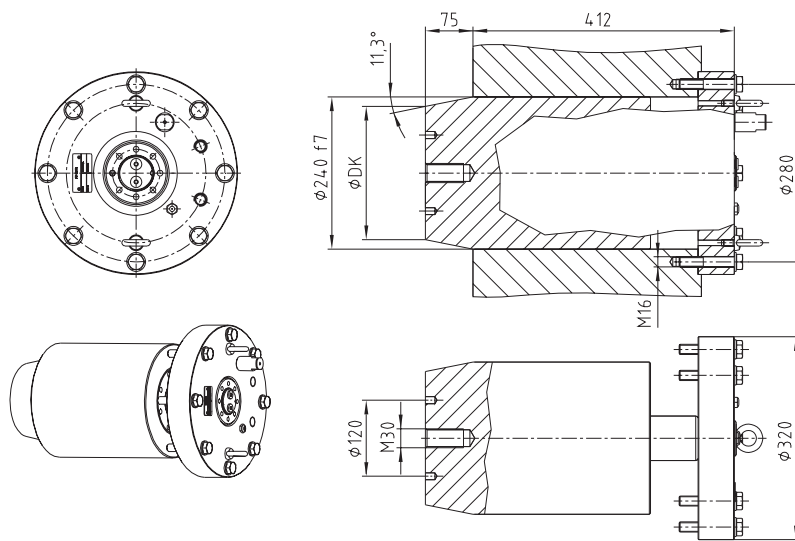

Mechanical version

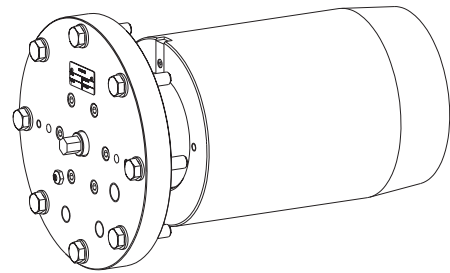

$$M_L = z \cdot F_L \cdot \frac{D_{\text{eff.}}}{2}$$

- F_L = Lateral force [kN]
 M_L = Lock torque [kNm]
 z = Number of Rotor Lock
 $D_{\text{eff.}}$ = Pitch circle diameter of locking disc [m]

KTR-STOP® RL M

Weight	Approx. 150 kg	Piston diameter	120 mm
Max. stroke	80 mm	Piston area fore stroke	113,10 cm ²
Max. lateral force ¹⁾	4000 kN	Piston area back stroke	74,61 cm ²
Max. operating pressure	250 bar	Oil volume per 1 mm stroke	11,3 cm ³
Max. force fore stroke F+	283 kN	Oil volume with 75 mm stroke (full stroke)	848,2 cm ³
Max. force back stroke F-	187 kN	Pressure port	1/4" BSP

¹⁾ Please note that the lateral force refers to the Rotor Lock only.

Assembly dimension

Housing

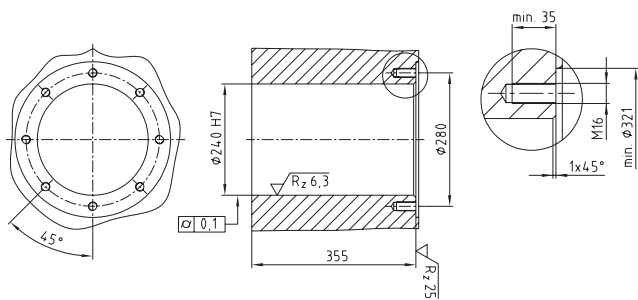

Locking disc

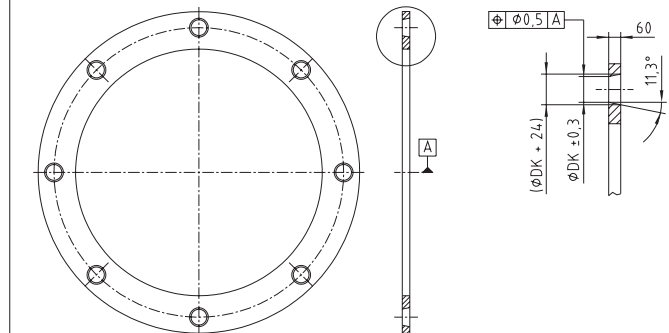

Order form:

KTR-STOP® RL	M	-	A	-	355
KTR Rotor Lock	Rotor Lock size		Variation		Length of installation

Product description

IntelliRamp® is an electronic control system allowing for program-controlled, accurate brake processes. Being combined with IntelliRamp®, our brakes are therefore suitable for the use in sophisticated applications:



- Ramp-supported brake process
 - Continuous deceleration operation
 - Continuous time operation
 - Continuous speed operation
- Excessive speed monitoring
- Reverse lock
- Joystick control
- Online remote operation

Function/Design

The operation of IntelliRamp® is based on the so-called pulse-width modulation. Here pulse-width modulation means to activate the brake calliper by partial unlocking and locking within a certain ratio during a constant time interval. Throttles which are included in the hydraulic system make sure that the brake callipers do not unlock and lock fully, but that the pressure during one control cycle is either increased or reduced. The benefit of the principle of pulse-width modulation is that no important volume flows are necessary to activate the brakes. This fact renders possible that a power voltage is not necessarily required during the brake process. Since only a pressure pulsation needs to be initiated, a small hydraulic storage is sufficient. As a result IntelliRamp® only needs a voltage providing the controller and the valves with a voltage. This voltage can be assured by means of a simple uninterruptible current supply which is available on almost every PLC. That is why the system can be described as being safe from power breakdown.



Operation

The control system is operated via touch screen with menu navigation. Other relays are not necessary which increases the availability and reliability of IntelliRamp® significantly.

Ramp-supported braking process

The ramp-supported braking process is activated by a signal safe from cable break. The process is performed via a closed control circuit with speed against time. Since a proportional control is not needed here, the system is safe from power breakdown, i. e. it will work even if the current supply fails. The ramp is defined by a rated speed and a braking time taking this speed into account.

Since a speed which is almost zero cannot be measured accurately any longer, a brake process exists increasing the brake power to achieve the full figure from a certain speed within a period to be defined.

For the ramp a tolerance range is defined which a control is performed in. Falling below this range the brake unlocks, exceeding this range the brake locks fully. The tolerance range can be defined flexibly. The closer the definition, the more accurate is the control, but at the same time the more nervous is the reaction.

In order to avoid impacts in the beginning of the brake process, the power with which the brake initiates the brake process can be defined by means of a parameter, too.

IntelliRamp® allows to use three brake ramps which can each be programmed individually and which can be started irrespective of each other.

Scheme of the ramp-supported brake process

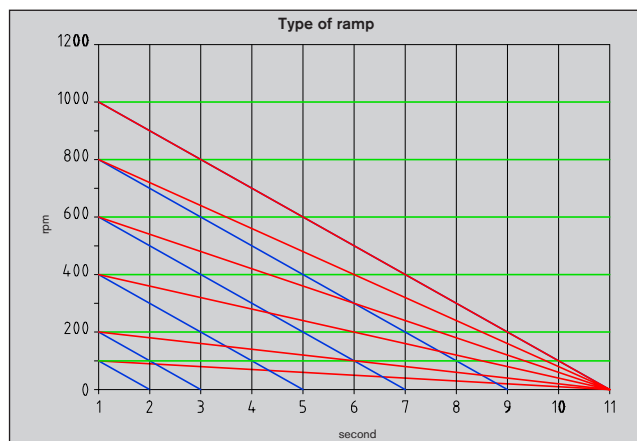

- Continuous deceleration:
With a higher speed the brake cycle takes longer, with a lower speed it is shorter.
- Continuous time operation:
The same time is always kept which means that the brake engages further if the speed is higher.
- Continuous speed control:
An option to keep the device at a constant speed via the brake only.

Description of operation

Excessive speed control

The action of excessive speed reacts flexibly within defined excessive speed barriers. Two values can be defined by which either a message is given to the PLC, a brake ramp is activated or an emergency stop is activated immediately without performing any control of this brake process. The excessive speed control can be switch on and off.

Reverse lock

It allows for controlling the speed. In case of an unauthorised rotational direction of the system a brake process is activated or the starting of the device is prevented. A definition of the number of starts preventing a re-start if the number is exceeded is to prevent the device from reversing in case of a fracture of the drive.

Joystick control

This is an option to use the brake, as an example, like a car brake. The more the joystick travels, the more the brake engages.

Online remote operation

The online remote operation allows both to call the status of the control via a network and to interfere. There is the option to program the control from a place far away.

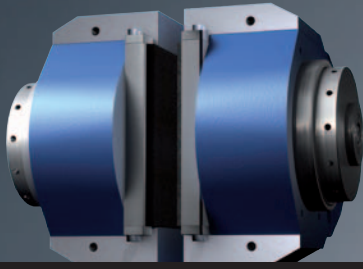

KTR-STOP®

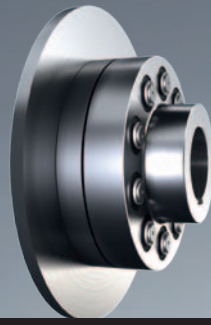

Coupling with brake disc

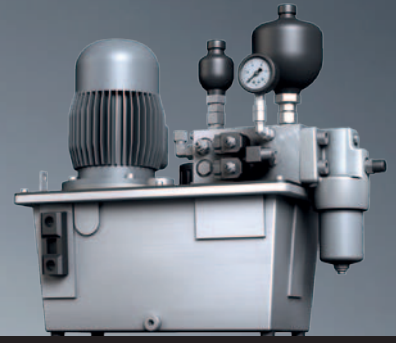

Hydraulics

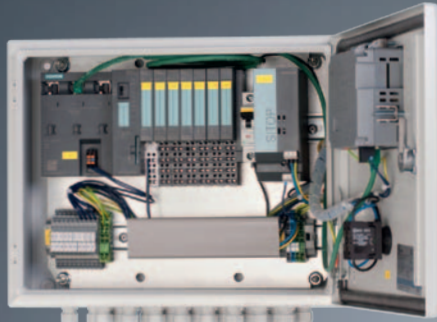

IntelliRamp®

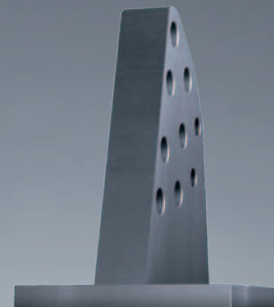

Stand

Everything from one single source. KTR – your system supplier

KTR-STOP®

KTR-STOP® is the recently developed brake system of KTR. It was designed for applications with high forces and adverse environmental conditions.

Coupling with brake disc

KTR produce drive components for numerous industrial applications. Our couplings are often delivered combined with an integrated brake disc.

Hydraulics

The brake calipers of KTR-STOP® are activated via the hydraulic power pack. For that purpose we provide for power packs with solid components for a reliable use under the hardest conditions.

IntelliRamp®

IntelliRamp® is the newly developed control system performing brake processes reproducibly with the variables speed against time.

Stand

The steel plate serves for supporting the KTR-STOP® brake systems and is adapted to the individual application by KTR.

Headquarter:
KTR Kupplungstechnik GmbH
Postfach 1763
D-48407 Rheine
Phone: +49(0)5971 798-0
Fax: +49(0)5971 798-698 and 798-450
E-mail: mail@ktr.com
Internet: www.ktr.com

Thomas Wienkotte
Dipl.-Ing. (FH)
Sales Manager Brakes
Peter-Schumacher-Straße 102
50171 Kerpen
Phone: +49(0)2237 971796
Fax: +49(0)2237 971795
Mobile: +49(0)172 5859448
E-mail: t.wienkotte@ktr.com



KTR worldwide:

Belgium/Luxemburg

KTR Benelux B. V. (Bureau Belgien)
Blancefloerlaan 167/22
B-2050 Antwerp
Phone: +32 3 2110567
Fax: +32 3 2110568
E-mail: ktr-be@ktr.com

Brazil

KTR do Brasil Ltda.
Rua Jandaia do Sul 471 -
Bairro Emiliano Pemeta
Pinhais - PR - Cep: 83321-040
Brasil
Phone: +55 41 36 69 57 13
Fax: +55 41 36 69 57 13
E-mail: ktr-br@ktr.com

China

KTR Power Transmission Technology
(Shanghai) Co. Ltd.
Floor 1 & 2, Bldg. B
No. 1501 JinSui Road
Pudong
Shanghai 201206
China
Phone: +86 21 50 32 08 80
Fax: +86 21 50 32 06 00
E-mail: ktr-cn@ktr.com

Czech Republic

KTR CR, spol. s. r. o.
Olomoucká 226
CZ-569 43 Jevicko
Phone: +420 461 325 014
Fax: +420 461 325 162
E-mail: ktr-cz@ktr.com

Finland

KTR Finland OY
Tiistinniityntie 2
SF-02230 Espoo
PL 23
SF-02231 Espoo
Phone: +358 2 07 41 46 10
Fax: +358 2 07 41 46 19
E-mail: ktr-fi@ktr.com

France

KTR France S.A.R.L.
46 - 48 Chemin de la Bruyère
F-69570 Dardilly
Phone: +33 478 64 54 66
Fax: +33 478 64 54 31
E-mail: ktr-fr@ktr.com

Great Britain

KTR Couplings Ltd.
Robert House
Unit 7, Acorn Business Park
Woodseats Close
Sheffield,
England, S8 0TB
Phone: +44 11 42 58 77 57
Fax: +44 11 42 58 77 40
E-mail: ktr-uk@ktr.com

India

KTR Couplings (India) Pvt. Ltd.,
T-36 / 37 / 38, MIDC Bhosari,
Pune 411 026
India
Phone: +91 20 27 12 73 22
Fax: +91 20 27 12 73 23
E-mail: ktr-in@ktr.com

Italy

KTR Kupplungstechnik GmbH
Sede senza rappresentanza stabile sul
Territorio Nazionale,
Via Fermi, 25
I-40033 Casalecchio di Reno (BO)
Phone: +39 051 613 32 32
Fax: +39 02 700 37 570
E-mail: ktr-it@ktr.com

Japan

KTR Japan Co., Ltd.
3-1-23 Daikaidori
Hyogo-ku, Kobe-shi
652-0803 Japan
Phone: +81 7 85 74 03 13
Fax: +81 7 85 74 03 10
E-mail: ktr-jp@ktr.com

KTR Japan - Tokyo Office

1-11-6, Higashi-Ueno, Taito-Ku,
Tokyo 110-0015 Japan
(Takeno-building, 5F)
Japan
Phone: +81 3 58 18 32 07
Fax: +81 3 58 18 32 08

Korea

KTR Korea Ltd.
101, 978-10, Topyung-Dong
Guri-City, Gyeonggi-Do
471-060 Korea
Phone: +82 3 15 69 45 10
Fax: +82 3 15 69 45 25
E-mail: ktr-kr@ktr.com

Netherlands

KTR Benelux B. V.
Postbus 87
NL-7550 AB Hengelo (O)
Adam Smithstraat 37
NL-7559 SW Hengelo (O)
Phone: +31 74 2505526
Fax: +31 74 2502466
E-mail: ktr-nl@ktr.com

Norway

KTR Kupplungstechnik Norge AS
Fjellbovegen 13
N-2016 Frogner
Phone: +47 64 83 54 90
Fax: +47 64 83 54 95
E-mail: ktr-no@ktr.com

Poland

KTR Polska SP. Z. O. O.
ul. Czerwone Maki 65
PL - 30-392 Kraków
Phone: +48 12 267 28 83
Fax: +48 12 267 07 66
E-mail: ktr-pl@ktr.com

Portugal

KTR Kupplungstechnik GmbH
c) Estartetxe, nº 5 - Oficina 218
E-48940 Leioa (Vizcaya)
Phone: +34 9 44 80 39 09
Fax: +34 9 44 31 68 07
E-mail: ktr-es@ktr.com

Russia

KTR Privodnaya tehnika, LLC
Sverdlovskaya Naberezhnaya 60,
Litera A, Office 1-N
195027 St. Petersburg
Russia
Phone: +7 812 495 62 72
Fax: +7 812 495 62 73
E-mail: mail@ktru
Internet: www.ktru

Spain

KTR Kupplungstechnik GmbH
c) Estartetxe, nº 5 - Oficina 218
E-48940 Leioa (Vizcaya)
Phone: +34 9 44 80 39 09
Fax: +34 9 44 31 68 07
E-mail: ktr-es@ktr.com

Sweden

KTR Sverige AB
Box 742
S - 191 27 Sollentuna
Phone: +46 86 25 02 90
Fax: +46 86 25 02 99
E-mail: info.se@ktr.com

Switzerland

KTR Kupplungstechnik AG
Bahnstr. 60
CH - 8105 Regensdorf
Phone: +41 4 33 11 15 55
Fax: +41 4 33 11 15 56
E-mail: ktr-ch@ktr.com

Taiwan

KTR Taiwan Ltd.
1 F, No.: 17, Industry 38 Road
Taichung Industry Zone
Taichung
Taiwan, R. O. C.
Phone: +886 4 23 59 32 78
Fax: +886 4 23 59 75 78
E-mail: j.wu@ktr.com

Turkey

KTR Turkey
İstanbul/Turkey
Phone: +90 541 334 33 40
E-mail: b.ozdek@ktr.com

USA

KTR Corporation
122 Anchor Road
Michigan City, Indiana 46360
USA
Phone: +1 2 19 8 72 91 00
Fax: +1 2 19 8 72 91 50
E-mail: ktr-us@ktr.com

KTR Kupplungstechnik GmbH

P.O. Box 1763

D-48407 Rheine

Phone: +49(0)5971 798-0

Fax: +49(0)5971 798-698 and 798-450

E-mail: mail@ktr.com

Internet: www.ktr.com

Made for Motion

