



**GEARex®**  
All-steel gear coupling

Made for Motion



## Table of contents



<b>GEARex®</b>	
<b>All-steel gear coupling</b>	111
Operating description	113
Coupling selection	114
Type FA, type FB and type FAB	115
Type DA, type DB and type DAB	116
Type FH and type DH	115
Type FR and tyoe DR	118
Displacements	119
Flange dimensions	120

## Operating description

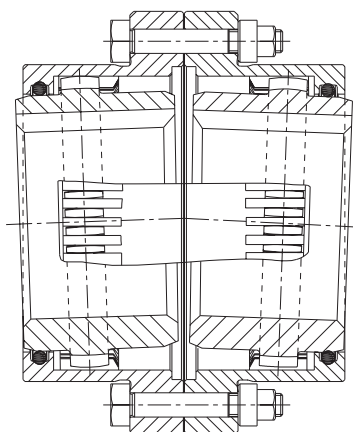

GEARex® couplings made of steel with grease lubrication and toroidal sealing ring correspond to the international standard. Being flexible shaft connections they are suitable for a positive torque transmission. In addition, they ensure to compensate for axial, radial and angular shaft displacements.

GEARex® couplings are used in every range of general engineering requesting for high operating safety and a long service life resulting from the reliable grease lubrication of the crowned spline. The couplings are suitable for horizontal assembly. As special solutions they are suitable for vertical assembly, too.

Numerous coupling sizes for a torque transmission from 930 Nm to 1.050.000 Nm with shaft dimensions up to a maximum of Ø 450 mm are available. The coupling torques may be increased by using special materials.

GEARex® couplings are in correspondence with the AGMA standard (American Gear Manufacturer Association). Small dimensions and a low weight along with a small mass moment of inertia result in a wide range of applications of GEARex® couplings.

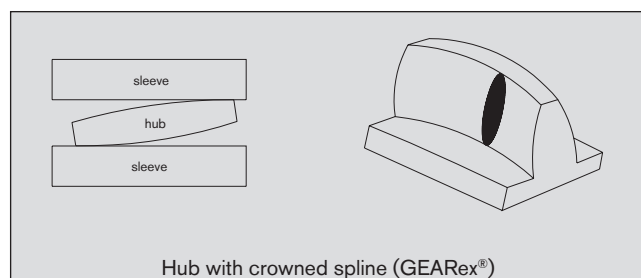

According to the operating principle of the well-known crowned gear, edge pressure in the spline is avoided in case of angular and radial displacements. Moreover, permanent grease lubrication produces a better friction ratio of the spline with an operation almost free from wear along with a long service life expectancy of the coupling.

In order to ensure a regular and controlled lubrication in assembled condition, two connections for hydraulics are arranged opposite to each other radially on each coupling sleeve. As a result a complete GEARex® coupling has four connections being offset to each other by 90°. The interior of the coupling is sealed by means of toroidal sealing

rings (NBR 70 ShA). The feather keys have to be sealed against escape of lubricants during the assembly.

### Explosion-proof use

GEARex® couplings are suitable for power transmission in drives in hazardous areas. The couplings are certified and confirmed according to EC standard 94/9/EC (ATEX 95) as units of category 2G/2D and thus suitable for the use in hazardous areas of zone 1, 2, 21 and 22. Please read through our information included in the respective Type Examination Certificate and the operating and mounting instructions at [www.ktr.com](http://www.ktr.com).



## Coupling selection

The coupling has to be dimensioned in a way that the permissible coupling load is not exceeded during any operating condition. For that purpose the loads that are produced have to be compared to the permissible characteristic figures of the coupling.

### 1 Coupling selection

The coupling is selected according to the rated torque ( $T_{KN}$ ). For that purpose the corresponding operating factors of the driving machine have to be taken into account, see starting factor  $S_Z$  and operating factor  $S_B$ .

### 2 Load of the coupling

$$T_{KN} \geq T_{NS}$$

$$T_{NS} \geq T_N \cdot S_Z \cdot S_B$$

$$T_N \text{ [Nm]} = 9550 \cdot P \text{ [kW]} / n \text{ [rpm]}$$

$$T_{Kmax.} \geq T_S$$

$T_{KN}$  = rated torque of coupling

$T_N$  = driving torque

$T_{NS}$  = driving torque including operating factors

$T_S$  = peak torque of machine (starting torque)

$S_Z$  = starting factor

$S_B$  = operating factor

### 3 Starting torque

The permissible starting torque of the machine should not exceed two times the rated torque of the coupling.

### 4 Permissible load on the feather key of the coupling

The shaft-hub-connection should be verified by the customer. Permissible surface pressure according to DIN 6892 (method C).

### 5 Permissible temperature range

The coupling can be used in a temperature range from -20 °C to +80 °C.

### 6 Example of selection

Electric motor: 30 kW  
 Application: textile machine →  $S_B = 1,25$   
 Shaft Ø: 70/65 mm  
 Speed: 250 rpm  
 Starts: < 10/h →  $S_Z = 1,0$   
 Starting torque:  $2,5 \cdot T_N$

$$T_N \text{ [Nm]} = 9550 \cdot 30 \text{ [kW]} / 250 \text{ [rpm]} = 1146 \text{ Nm}$$

$$T_{NS} = 1146 \text{ Nm} \cdot 1 \cdot 1,25 = 1432,5 \text{ Nm}$$

$$T_S = 1146 \text{ Nm} \cdot 2,5 = 3581 \text{ Nm}$$

### Coupling selected:

GEARex® 15 ( $T_{KN} = 2000 \text{ Nm}$ ;  $T_{Kmax.} = 4000 \text{ Nm}$ )

Service factor $S_Z$ for starting frequency			
Starting frequency/h	10	25	50
$S_Z$	1,0	1,2	1,4

Operating factor $S_B$			
Kind of load	Operating features	Machines	Operating factor
Smooth	Permanent operation without overload or shock load. Low connecting frequency.	<ul style="list-style-type: none"> <li>- Electric generators</li> <li>- Radial pumps</li> <li>- Light-weight fans</li> </ul>	1,00
Light-weight	Permanent operation with small overload and short-term and rare shock load.	<ul style="list-style-type: none"> <li>- Multistage radial compressors</li> <li>- Piston pumps</li> <li>- Large fans (heavy load operation)</li> <li>- Agitators for liquids</li> <li>- Agitators for solid matters</li> <li>- Textile machines</li> <li>- Machine tools</li> <li>- Belt conveyor</li> <li>- Lifting equipment</li> </ul>	1,25
Average	Interrupted operation with low shock load and short-term average overload.	<ul style="list-style-type: none"> <li>- Piston compressors, cranes (running or drawing operation)</li> <li>- Hoisting machines, calendars for rubber and nylon</li> <li>- Calenders</li> <li>- Rolling mill drives</li> <li>- Non-reversing cold rolling mills</li> </ul>	1,50
Heavy	Operation with heavy and frequent shock load. Frequent load reversion. High degree of safety.	<ul style="list-style-type: none"> <li>- Bridge cranes for steel industry</li> <li>- Agitators for rubber and nylon</li> <li>- Cranes (heavy load operation)</li> <li>- Wood grinders, marine drives</li> <li>- Equipment for transport of persons</li> <li>- Mine fans</li> <li>- Roller tables</li> <li>- Non-reversing cold rolling mills</li> <li>- Reversing cold rolling mills</li> <li>- Hot-rolling mill</li> </ul>	2,00
Very heavy	Extreme and overload with frequent and sudden load reversion.	<ul style="list-style-type: none"> <li>- Reversing rolling mill drives</li> <li>- Heavy load operation in steel industry</li> <li>- Slitting machines</li> <li>- Grinding machines</li> <li>- Scissors and cutters</li> <li>- Crushers</li> </ul>	2,50

**Type FA, type FB and type FAB**



- Coupling in accordance with AGMA 9008-B00
- Double-cardanic crowned gear coupling
- To be used on all applications in general engineering
- Compensating for shaft misalignment axial – radial – angular
- Available with finish bore to ISO fit H7, feather key according to DIN 6885 sheet 1, taper and inch bores
- For horizontal assembly
- Higher torques to be realized by special materials
- Approved and confirmed according to EC Standard 94/9/ EC (Explosion Certificate ATEX 95)
- Max. torque of coupling  $T_{Kmax.} = 2 \cdot T_{KN}$

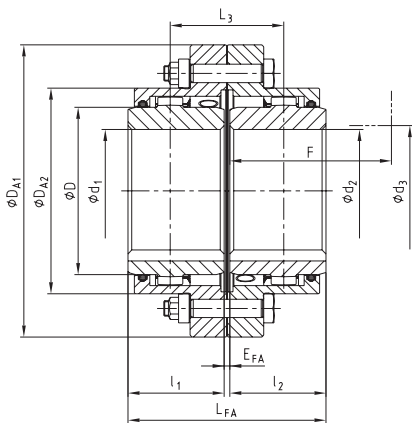

**Type FA**

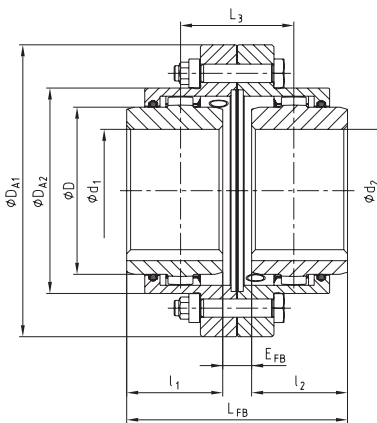

**Type FB**

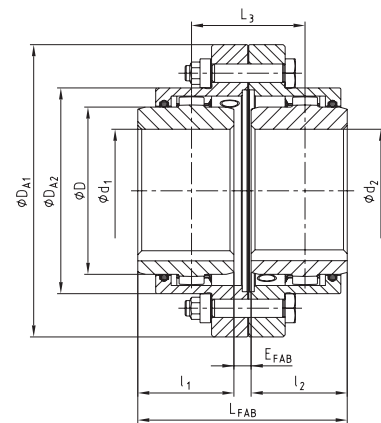

**Type FAB**

**Dimensions**

Size	Pilot bored	Max. finish bore		Dimensions [mm]															Grease <sup>2)</sup> feeding [dm <sup>3</sup> ]
		d <sub>1</sub> ; d <sub>2</sub>	l <sub>1</sub> ; l <sub>2</sub>	Hub lengthened max l <sub>1</sub> , l <sub>2</sub>	E <sub>FA</sub>	E <sub>FB</sub>	E <sub>FAB</sub>	L <sub>FA</sub>	L <sub>FB</sub>	L <sub>FAB</sub>	L <sub>3</sub>	D	D <sub>A1</sub>	D <sub>A2</sub>	F <sup>1)</sup>	d <sub>3</sub> <sup>1)</sup>			
10	26	50	43	105	3	21	12	89	107	98	55	67	111	84	74	52	0,02		
15	26	64	50	115	3	15	9	103	115	109	59	87	152	107	84	68	0,04		
20	31	80	62	130	3	31	17	127	155	141	79	108	178	130	104	85	0,08		
25	38	98	76	150	5	29	17	157	181	169	93	130	213	158	123	110	0,12		
30	44,5	112	90	170	5	33	19	185	213	199	109	153	240	182	148	130	0,18		
35	46	133	105	185	6	40	23	216	250	233	128	180	280	214	172	150	0,22		
40	52	158	120	215	6	42	24	246	282	264	144	214	318	250	192	175	0,35		
45	80	172	135	245	8	50	29	278	320	299	164	233	347	274	216	190	0,45		
50	80	192	150	295	8	56	32	308	356	332	182	260	390	309	241	220	0,70		
55	90	210	175	300	8	70	39	358	420	389	214	283	425,5	334	275	250	0,90		
60	100	232	190	305	8	84	46	388	464	426	236	312	457	365,5	316	265	1,15		
70	100	276	220	310	10	76	43	450	516	483	263	371	527	425	360	300	1,50		

**Technical data**

Size	Torque [Nm]		Max. speed [rpm]	Weight with max. bore [kg]			Mass moment of inertia J with max. bore Ø [kgm <sup>2</sup> ]	Dowel screws (10.9)		
	T <sub>KN</sub>	T <sub>KN</sub> (42CrMo4)		Sleeve	Hub	Total		z	M	T <sub>A</sub> [Nm]
10	930	1580	8500	0,75	0,55	2,73	0,00436	6	M6	15
15	2000	3300	7700	1,88	1,12	6,38	0,01894	8	M8	36
20	3500	6300	6900	2,60	2,09	9,94	0,04000	6	M10	72
25	6500	11000	6200	4,43	3,56	16,83	0,09749	6	M12	125
30	10000	17400	5800	5,83	6,18	25,21	0,18080	8	M12	125
35	17000	28800	5100	9,71	9,87	41,25	0,41419	8	M14	200
40	28500	48500	4500	11,88	16,07	58,14	0,75535	8	M14	200
45	37000	62000	4000	15,72	21,42	77,08	1,17590	10	M14	200
50	51000	86000	3750	25,66	29,59	114,40	2,24991	8	M18	430
55	65000	110000	3550	31,52	40,30	150,41	3,45102	14	M18	430
60	85000	145000	3400	32,82	52,96	177,44	4,16734	14	M18	430
70	135000	240000	3200	43,52	85,77	268,20	9,32429	16	M20	610

<sup>1)</sup> Space required to align the coupling or replace the sealing ring, respectively.

<sup>2)</sup> Grease feeding for each coupling half

<b>Ordering example:</b>	GEARex® FA 10	d <sub>1</sub> Ø50	d <sub>2</sub> Ø50
	Size and type of coupling	Finish bore with keyway DIN 6885 sheet 1	Finish bore with keyway DIN 6885 sheet 1

**Type DA, type DB and type DAB**

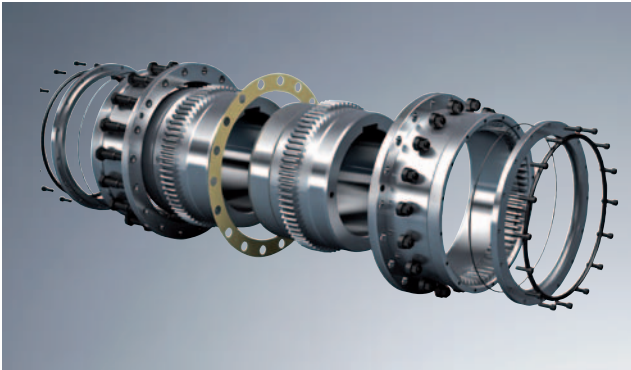

- Double-cardanic crowned gear coupling
- To be used on all applications in general engineering
- Compensating for shaft misalignment axial – radial – angular
- Available with finish bore to ISO fit H7, feather key according to DIN 6885 sheet 1, taper and inch bores
- For horizontal assembly
- Higher torques to be realized by special materials
- Approved and confirmed according to EC Standard 94/9/EC
- Max. torque of coupling  $T_{Kmax.} = 2 \cdot T_{KN}$

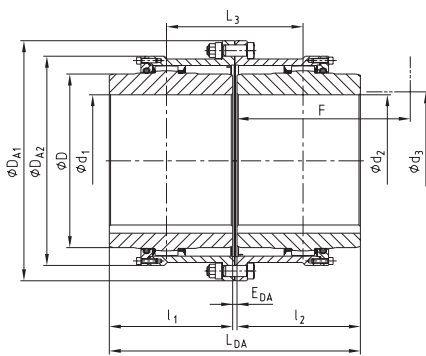

**Type DA**

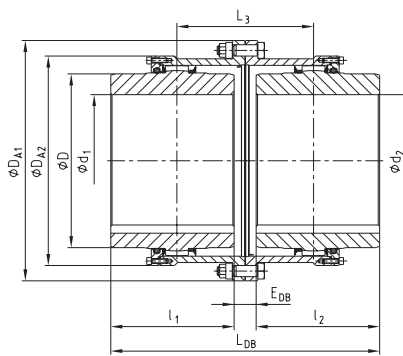

**Type DB**

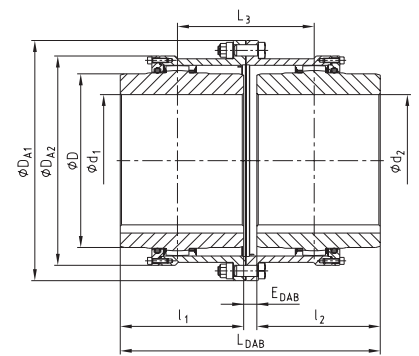

**Type DAB**

Dimensions																
Size	Pilot bored	Max. finish bore		Dimensions [mm]												Grease <sup>2)</sup> feeding [dm <sup>3</sup> ]
		d <sub>1</sub> ; d <sub>2</sub>	l <sub>1</sub> , l <sub>2</sub>	E <sub>DA</sub>	E <sub>DB</sub>	E <sub>DAB</sub>	L <sub>DA</sub>	L <sub>DB</sub>	L <sub>DAB</sub>	L <sub>3</sub>	D	DA <sub>1</sub>	DA <sub>2</sub>	F <sup>1)</sup>	d <sub>3</sub> <sup>1)</sup>	
20	31	80	62	3	31	17	133	155	144	79	108	187	146	105	85	0,08
25	38	98	76	5	29	17	157	181	169	93	130	220	172	115	105	0,12
30	44,5	112	90	5	33	19	185	213	199	109	153	248	182	140	120	0,18
35	46	133	105	6	40	23	216	250	233	128	180	285	214	165	145	0,22
40	52	158	120	6	42	24	246	282	264	144	214	335	250	180	160	0,35
45	80	172	135	8	50	29	278	320	299	164	233	358	294	195	185	0,45
50	80	192	150	8	56	32	388	356	332	182	260	390	309	215	205	0,70
55	90	210	175	8	70	39	358	420	389	214	283	425,5	348	240	220	0,90
60	100	232	190	8	84	46	388	464	426	236	312	457	380	260	245	1,15
70	100	276	220	10	76	43	450	516	483	263	371	527	445	300	290	1,50
80	140	300	280	10	50	30	570	610	590	310	394	545	475	340	310	2,50
85	160	325	292	13	53	33	597	637	617	325	430	585	515	352	330	3,00
90	180	350	305	13	83	48	623	693	658	353	464	640	560	365	360	4,00
100	220	390	330	13	93	53	673	753	713	383	512	690	612	390	400	5,00
110	220	420	350	20	296	158	720	996	858	508	560	765	665	410	420	6,00
120	260	450	420	25	421	223	864	1261	1063	643	608	825	720	480	470	7,50

Technical data										
Size	Torque [Nm]		Max. speed [rpm]	Weight with max. bore [kg]			Mass moment of inertia J with max. bore Ø [kgm <sup>2</sup> ]	Dowel screw (10.9)		
	T <sub>KN</sub>	T <sub>KN</sub> (42CrMo4)		Sleeve	Hub	Total		z	M	T <sub>A</sub> [Nm]
80	175000	300000	1900	64	117	362	14,214	18	M20	610
85	225000	380000	1900	75	148	446	20,320	20	M20	610
90	290000	500000	1700	101	183	568	31,036	20	M24	1000
100	380000	650000	1600	117	232	698	45,358	24	M24	1000
110	480000	820000	1450	140	295	940	73,880	20	M30	1700
120	620000	1050000	1350	188	430	1312	118,40	24	M30	1700

<sup>1)</sup> Space required to align the coupling or replace the sealing ring, respectively.  
<sup>2)</sup> Grease feeding for each coupling half

<b>Ordering example:</b>	GEARex® DA 80	d <sub>1</sub> Ø300	d <sub>2</sub> Ø300
	Size and type of coupling	Finish bore with keyway DIN 6885 sheet 1	Finish bore with keyway DIN 6885 sheet 1

**Type FH and type DH**

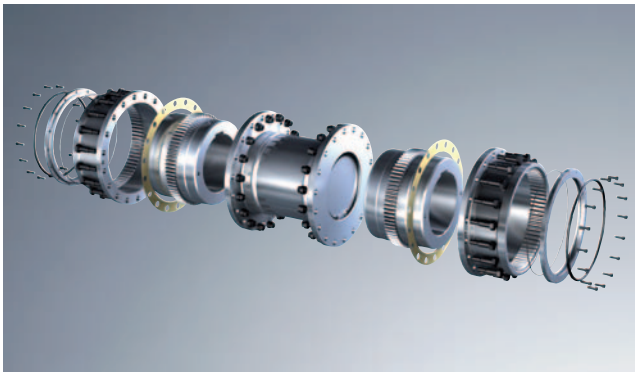

- Coupling type for bigger shaft distance dimensions
- Type FH with single-parted sleeve GEARex® size 10 to 70
- Type DH with split sleeve GEARex® size 80 to 120
- Higher torques to be realized by special materials
- Available with finish bore to ISO fit H7, feather key according to DIN 6885 sheet 1, taper and inch bores
- Max. torque of coupling  $T_{Kmax.} = 2 \cdot T_{KN}$

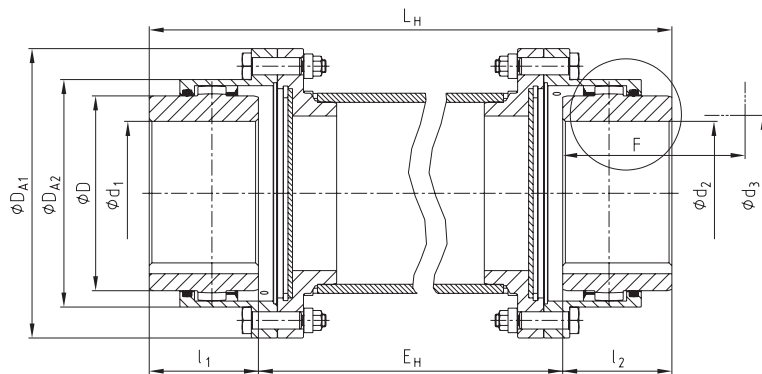

**Ausführungen**

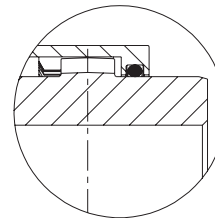

**Type FH**

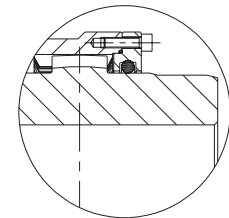

**Type DH**

**Dimensions**

Size	Torque [Nm]		Pilot bored	Max. finish bore d1; d2	Dimensions [mm]								Dowel screw (10.9)			Grease <sup>2)</sup> feeding [dm <sup>3</sup> ]	
	T <sub>KN</sub>	T <sub>KN</sub> (42CrMo4)			l <sub>1</sub> , l <sub>2</sub>	Hub lengthened l <sub>1</sub> , l <sub>2</sub> max.	D	DA1 <sup>3)</sup>	DA2 <sup>3)</sup>	L <sub>H</sub>	E <sub>H</sub>	F <sup>1)</sup>	d <sub>3</sub> <sup>1)</sup>	z	M		T <sub>A</sub> [Nm]
10	930	1580	26	50	43	105	67	111	84			74	52	6	M6	15	0,02
15	2000	3300	26	64	50	115	87	152	107			84	68	8	M8	36	0,04
20	3500	6300	31	80	62	130	108	178	130			104	85	6	M10	72	0,08
25	6500	11000	38	98	76	150	130	213	158			123	110	6	M12	125	0,12
30	10000	17400	44,5	112	90	170	153	240	182			148	130	8	M12	125	0,18
35	17000	28800	46	133	105	185	180	280	214			172	150	8	M14	200	0,22
40	28500	48500	52	158	120	215	214	318	250			192	175	8	M14	200	0,35
45	37000	62000	80	172	135	245	233	347	274			216	190	10	M14	200	0,45
50	51000	86000	80	192	150	295	260	390	309			241	220	8	M18	430	0,70
55	65000	110000	90	210	175	300	283	425,5	334			275	250	14	M18	430	0,90
60	85000	145000	100	232	190	305	312	457	365,5			316	265	14	M18	430	1,15
70	135000	240000	100	276	220	310	371	527	425			360	300	16	M20	610	1,50
80	175000	300000	140	300	280	-	394	545	475			340	310	18	M20	610	2,50
85	225000	380000	160	325	292	-	430	585	515			352	330	20	M20	610	3,00
90	290000	500000	180	350	305	-	464	640	560			365	360	20	M24	1000	4,00
100	380000	650000	220	390	330	-	512	690	612			390	400	24	M24	1000	5,00
110	480000	820000	220	420	350	-	560	765	665			410	420	20	M30	1700	6,00
120	620000	1050000	260	450	420	-	608	825	720			480	470	24	M30	1700	7,50

<sup>1)</sup> Space required to align the coupling or replace the sealing ring, respectively.

<sup>2)</sup> Grease feeding for each coupling half

<sup>3)</sup> Dimensions type F. Type D see page 116.

<b>Ordering example:</b>	GEARex® FH 10	d <sub>1</sub> Ø50	d <sub>2</sub> Ø50	250
	Size and type of coupling	Finish bore with keyway DIN 6885 sheet 1	Finish bore with keyway DIN 6885 sheet 1	Shaft distance dimension E <sub>H</sub>



**Type FR and type DR**

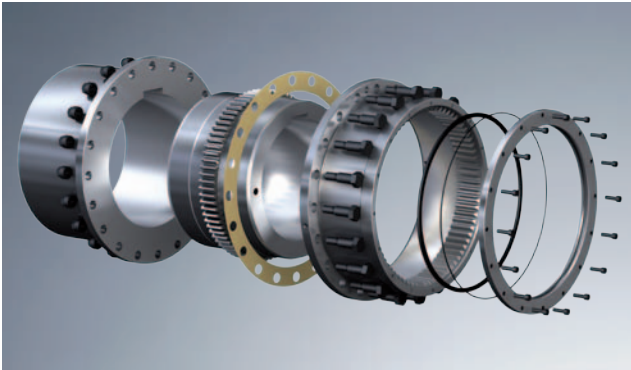

- Type FR with single-parted sleeve GEARex® size 10 to 70
- Type DR with split sleeve GEARex® size 80 to 120
- Higher torques to be realized by special materials
- Available with finish bore to ISO fit H7, feather key according to DIN 6885 sheet 1, taper and inch bores
- Max. torque of coupling  $T_{Kmax.} = 2 \cdot T_{KN}$

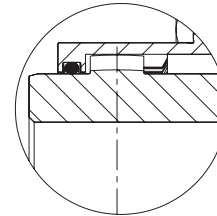
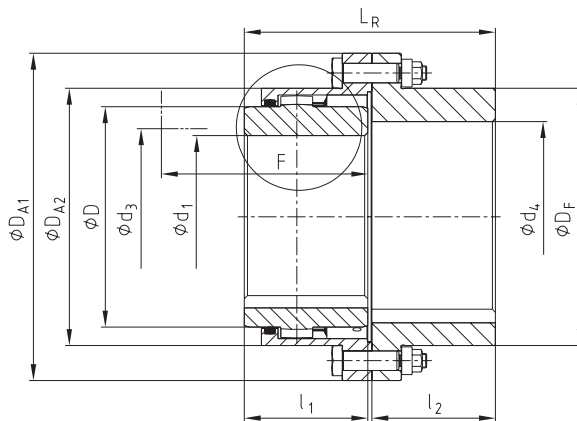

Type FR

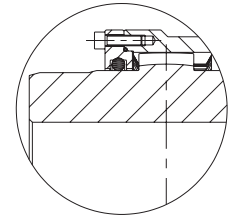

Type DR

Dimensions																	
Size	Torque [Nm]		Max. finish bore		Dimensions [mm]									Dowel screw (10.9)			Grease feeding [dm <sup>3</sup> ]
	T <sub>KN</sub>	T <sub>KN</sub> (42CrMo4)	d <sub>1</sub>	d <sub>4</sub>	l <sub>1</sub> , l <sub>2</sub>	Hub lengthened l <sub>1</sub> , l <sub>2</sub> max.	D	D <sub>A1</sub>	D <sub>A2</sub>	D <sub>F</sub>	L <sub>R</sub>	F <sup>1)</sup>	d <sub>3</sub> <sup>1)</sup>	z	M	T <sub>A</sub> [Nm]	
10	930	1580	50	60	43	105	67	111	84	84	88	74	52	6	M6	15	0,02
15	2000	3300	64	78	50	115	87	152	107	107	103	84	68	8	M8	36	0,04
20	3500	6300	80	95	62	130	108	178	130	130	127	104	85	6	M10	72	0,08
25	6500	11000	98	115	76	150	130	213	158	158	157	123	110	6	M12	125	0,12
30	10000	17400	112	135	90	170	153	240	182	182	185	148	130	8	M12	125	0,18
35	17000	28800	133	155	105	185	180	280	214	214	216	172	150	8	M14	200	0,22
40	28500	48500	158	185	120	215	214	318	250	250	244	192	175	8	M14	200	0,35
45	37000	62000	172	200	135	245	233	347	274	274	276	216	190	10	M14	200	0,45
50	51000	86000	192	225	150	295	260	390	309	309	305	241	220	8	M18	430	0,70
55	65000	110000	210	245	175	300	283	425,5	334	334	356	275	250	14	M18	430	0,90
60	85000	145000	232	265	190	305	312	457	365,5	365,5	386	316	265	14	M18	430	1,15
70	135000	240000	276	310	220	310	371	527	425	425	450	360	300	16	M20	610	1,50
80	175000	300000	300	340	280	-	394	545	475	462	570	340	310	18	M20	610	2,50
85	225000	380000	325	370	292	-	430	585	515	500	597	352	330	20	M20	610	3,00
90	290000	500000	350	400	305	-	464	640	560	546	623	365	360	20	M24	1000	4,00
100	380000	650000	390	440	330	-	512	690	612	594	673	390	400	24	M24	1000	5,00
110	480000	820000	420	480	350	-	560	765	665	647	710	410	420	20	M30	1700	6,00
120	620000	1050000	450	520	420	-	608	825	720	700	852	480	470	24	M30	1700	7,50

<sup>1)</sup> Space required to align the coupling or replace the sealing ring, respectively.

<b>Ordering example:</b>	GEARex® FR 10	d <sub>1</sub> Ø50	d <sub>4</sub> Ø60
	Size and type of coupling	Finish bore with keyway DIN 6885 sheet 1	Finish bore with keyway DIN 6885 sheet 1



**Displacements**

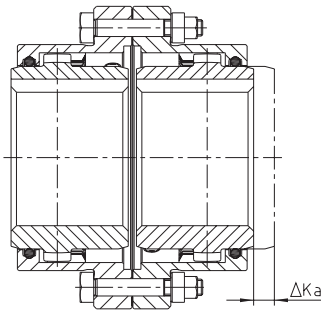

Axial displacement

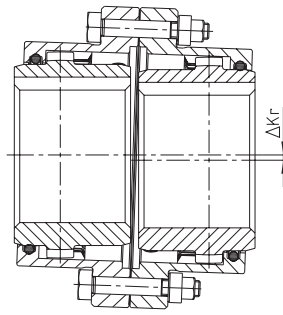

Radial displacement

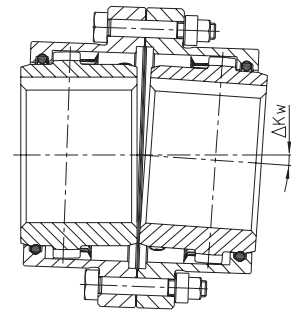

Angular displacement

Displacements			
Size	Max. axial displacement $\Delta K_a$ [mm]	Max. permissible displacements <sup>1)</sup>	
		$\Delta K_r$ [mm]	$\Delta K_w$ [°]
10		± 0,4	
15		± 0,5	
20		± 0,6	
25	± 1,0	± 0,8	
30		± 1,0	
35		± 1,0	
40		± 1,2	
45		± 1,4	
50		± 1,6	0,5° each hub
55	± 1,5	± 1,8	
60		± 2,0	
70		± 2,2	
80		± 2,5	
85		± 2,8	
90	± 2,0	± 3,0	
100		± 3,2	
110		± 4,4	
120		± 5,5	

<sup>1)</sup> The displacement figures are maximum figures which must not occur in parallel. If both radial and angular displacement arise at the same time, these figures have to be reduced (see examples of calculation and diagramme).

Example 1:  
 $\Delta K_r = 30\%$   
 $\Delta K_w = 70\%$

Example 2:  
 $\Delta K_r = 60\%$   
 $\Delta K_w = 40\%$

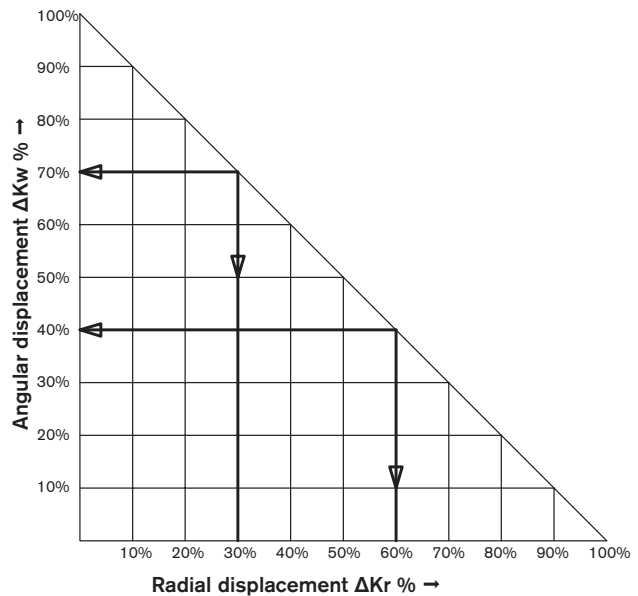

Flange dimensions in accordance with AGMA 9008-B00

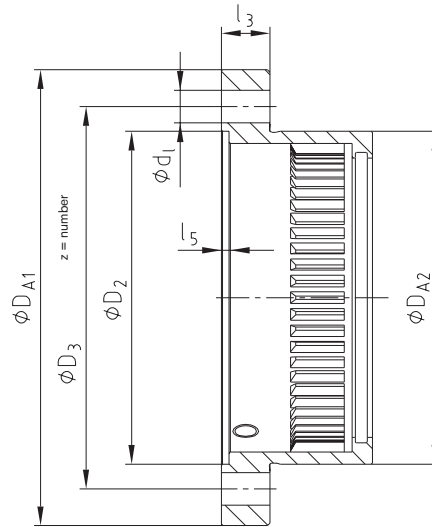

Flange dimensions								
Size	Dimensions [mm]							
	$D_{A1}$	$D_{A2}$	$D_2$	$D_3$	$d_l$	Number z	$l_3$	$l_5$
10	111	84	82	95,25	6,35	6	14	3
15	152	107	105	122,24	9,52	8	19	3
20	178	130	130	149,23	12,70	6	19	3
25	213	158	153	180,97	15,87	6	22	4
30	240	182	178	206,38	15,87	8	22	4
35	280	214	205	241,30	19,05	8	28,5	5
40	318	250	243	279,40	19,05	8	28,5	4
45	347	274	265	304,80	19,05	10	28,5	5,5
50	390	309	302	342,90	22,22	8	38	6
55	425,5	334	320	368,30	22,22	14	38	6
60	457	365,5	353	400,05	22,22	14	26	6
70	527	425	412	463,55	25,40	16	28,5	8

Other types

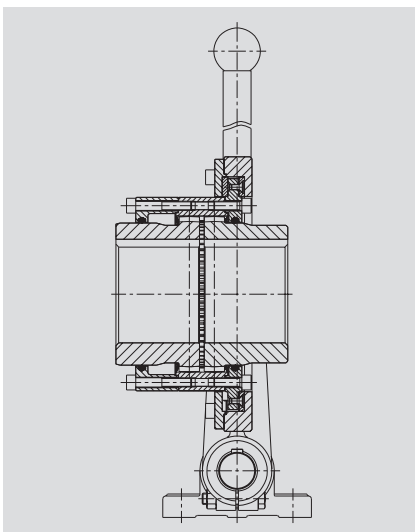

Type SD

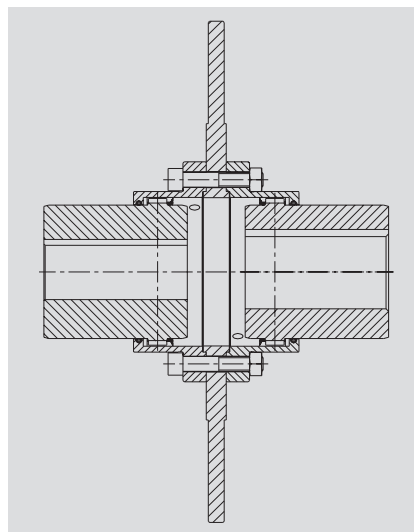

Type with brake disk

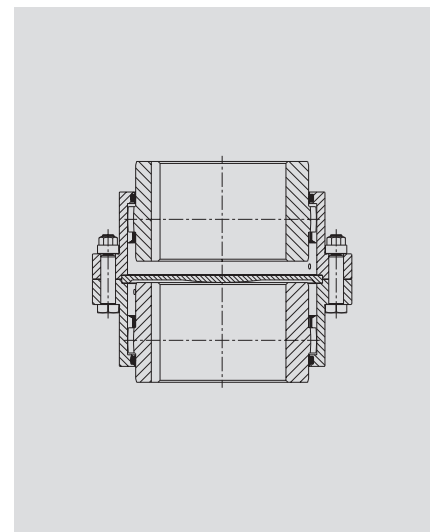

Type VD (vertical assembly)