

MINEX[®]-S

Magnetic coupling

Made for Motion



Table of contents

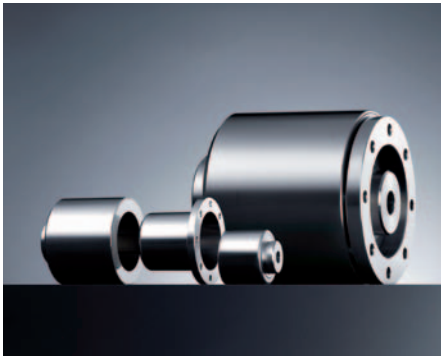

MINEX[®]-S	
Magnetic coupling	179
Coupling description	181
Technical description	182
Sizes SA 22/4 to SB 60/8 with containment shroud made of stainless steel	183
Sizes SA 75/10 to SF 250/38 with containment shroud made of stainless steel or Hastelloy	184
NEW Sizes SA 75/10 to SE 165/24 with containment shroud made of PEEK	186
Sizes SA 110/16 to SE 200/30 with containment shroud made of oxide ceramics	187
Mounting sets and customized assemblies	188

Coupling description

General description

MINEX[®]-S is a permanent-magnetic synchronous coupling that transmits the torque through magnetic forces between the internal and the external rotor. It ensures a hermetic separation of the drive and the driven side in its main function as sealing element in pumps and agitators. For critical media like aggressive acids, bases, etc. it serves as a reliable seal and prevents serious leakages occurring. On request KTR will manufacture special customer-specific types of the MINEX[®]-S in combination with KTR hydraulic components. Thus existing pumps with a conventional shaft seal can be easily retrofitted with the MINEX[®]-S.



Mode of operation/Design

Torque transmission

The coupling consists of an external and an internal rotor. The external rotor has high-quality, permanent magnets of changing polarity on the inner side and the internal rotor has them on the outside.

The external rotor is normally fixed on the drive side and the magnets are glued in the keyways.

The magnets of the driven-sided internal rotor are cylindrically ground to ensure a minimal air gap and encapsulated through a magnetic cover that is impervious to fluids.

In their non-operative states the north and south poles of the rotors are opposite to each other and the magnetic field is completely symmetric.

It is only when the rotors are twisted that the magnetic field lines are moved, hence the torque is transmitted through the air gap. Then there is a synchronous operation under a constant torsion angle. If the maximum coupling torque and the maximum torsion angle are exceeded, the power transmission is interrupted. Thus the MINEX[®]-S offers an overload protection function of the drive train. After removing the cause of the overload (e. g. damage to the bearing, blocking of the internal rotor) both rotors can be synchronised again and operation is resumed.

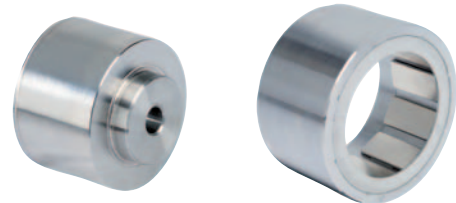

Internal rotor

External rotor

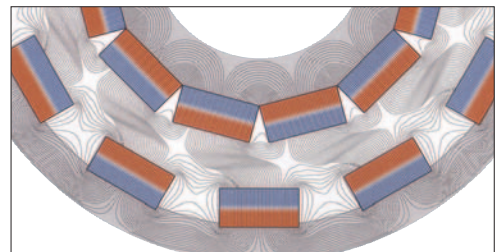

Run of flux lines

Sealing function

The main component of the MINEX[®]-S is the containment shroud that is fixed to the driven-sided power unit and separates internal and external rotor from each other. It ensures a low-vibration torque transmission working without mechanical connection and guarantees a completely leak-proof separation of product and atmosphere. The sealing is achieved with a flat seal or an O-ring, thus eliminating the need to dynamically load the sealing elements.

The standard designs of MINEX[®]-S include metallic containment shrouds made of stainless steel or Hastelloy, respectively. Inside the rotating magnetic field they generally cause losses of eddy current which are converted into heat and which may require cooling measures. On applications with pumps the heat produced can basically be dissipated by the medium to be pumped.

If eddy current losses can be definitely excluded, the energy-efficient alternative materials PEEK and ceramics are available. PEEK is first class with rather low pressures and temperatures (depending on size up to 16 bar and 130 °C). For higher performances up to 25 bar and 300 °C we would recommend to use containment shrouds made of ceramics.



Containment shroud

Technical description

Explosion-protection use

MINEX®-S couplings are suitable for the power transmission in drives that are scheduled to be used in explosive areas. According to the EU standards 94/9/EC (ATEX 95) the types with metallic containment shrouds are assessed and confirmed as components of the device class II and suitable for the use in explosive areas of category 2G.

Please see our website www.ktr.com for advice, copies of certification and operating/mounting instructions.



Technical data																
Size	Stat. tear torque T_K max. with 20 °C [Nm]	External rotor				Internal rotor				Containment shroud						
		Standard material		Max. operating temperature t_{max} [°C]	Weight unbored [kg]	Mass moment of inertia J with min. bore \varnothing [kgm ²]	Standard material		Max. operating temperature t_{max} [°C]	Weight pilot bored [kg]	Mass moment of inertia J with min. bore \varnothing [kgm ²]	Standard material ²⁾		Max. pressure resistance $P_N/p_{max.}$ ¹⁾ [bar]	Max. operating speed [rpm]	
		Hub	Magnets				Hub	Magnets				Flange	Shroud			
SA 22/4	0,15		NdFeB	150	0,13	$30,01 \times 10^{-6}$	1.4462	NdFeB	150	0,04	$1,912 \times 10^{-6}$		Stainless steel 1.4571	60/90	KTR	
SA 34/10	1		NdFeB	150	0,26	$117,4 \times 10^{-6}$				0,09	$12,1 \times 10^{-6}$		Stainless steel 1.4571	16/24		
SA 46/6	3		Samarium-cobalt (Sm ₂ Co ₁₇) or neodymium-iron-boron (NdFeB)	300 °C (Sm ₂ Co ₁₇) or 150 °C (NdFeB)	0,62	$458,6 \times 10^{-6}$				0,32	125×10^{-6}		Stainless steel 1.4571	40/60		
SA 60/8	7				1,75	2279×10^{-6}				0,56	221×10^{-6}					
SB 60/8	14				2,68	3759×10^{-6}				0,93	380×10^{-6}					
SA 75/10	10				1,36	3159×10^{-6}				0,94	539×10^{-6}					
SB 75/10	24				2,10	4829×10^{-6}				1,49	889×10^{-6}					
SC 75/10	40	Construction steel S355J2G3			2,89	6654×10^{-6}				1,89	1232×10^{-6}					
SB 110/16	60					2,82	12111×10^{-6}			3,73	5229×10^{-6}					
SC 110/16	95					3,79	16238×10^{-6}			4,85	7137×10^{-6}					
SB 135/20	100					3,75	22878×10^{-6}			5,67	12333×10^{-6}					
SC 135/20	145					4,90	29874×10^{-6}			7,36	16768×10^{-6}					
SD 135/20	200			6,06	36870×10^{-6}			9,50	22387×10^{-6}							
SC 165/24	210			5,31	45480×10^{-6}			11,40	37917×10^{-6}				25/37.5			
SD 165/24	280			6,56	56170×10^{-6}			14,67	50633×10^{-6}							
SE 165/24	370			7,81	66860×10^{-6}			17,30	60855×10^{-6}							
SD 200/30	430			9,89	117296×10^{-6}			26,06	125915×10^{-6}							
SE 200/30	550		10,36	122342×10^{-6}			26,11	126405×10^{-6}								
SD 250/38	670		10,93	202540×10^{-6}			37,92	282795×10^{-6}				16/24				
SE 250/38	820		13,03	241273×10^{-6}			45,22	340420×10^{-6}								
SF 250/38	1000		15,13	280000×10^{-6}			52,50	397915×10^{-6}								

¹⁾ Resistances to higher pressures can be realized on request of the customer.

²⁾ Alternative containment shroud materials like oxide ceramics (see page 187) and PEEK (see page 186) are available on request.

Description	Symbol	Definition or explanation
Static tear torque of coupling	T_K max.	Max. transmittable torque, from which onwards the magnetic forces tear during the static test.

Description	Symbol	Definition or explanation
Maximum operating temperature	t_{max} .	Max. permissible temperature causing a temporary attenuation of the magnetic field. Exceeding may generate irretrievable losses of magnetization.

Torque reduction with temperature increase

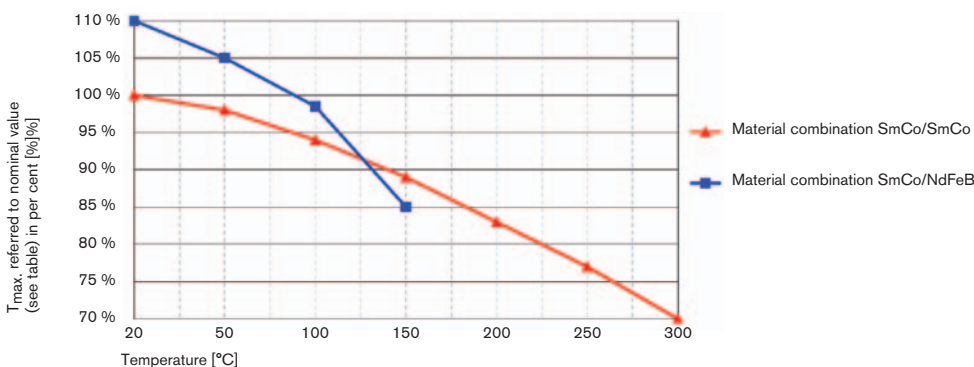

Temporary torque reduction with increased temperature for alternative material combinations [%]

Please note:

KTR recommends to use NdFeB magnets for the external rotor, provided that the operating temperature falls below 150 °C.

Sizes SA 22/4 to SB 60/8 with containment shroud made of stainless steel

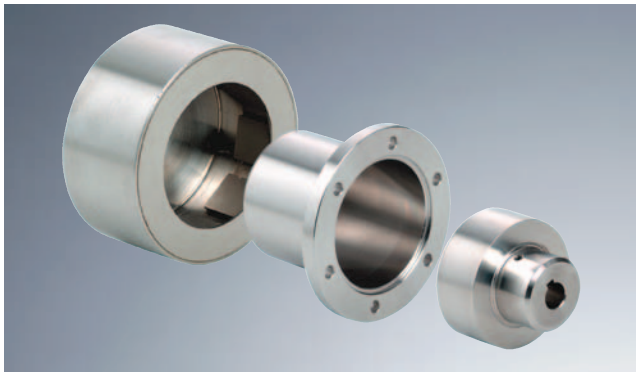

- Contactless torque transmission
- Hermetic separation of driving and driven side
- Containment shroud made of stainless steel 1.4571
- Available from stock with pilot bored internal rotor and unbored external rotor
- Finish bore possible to ISO H7, feather keyway to DIN 6885 sheet 1 - JS9
- Ⓢ-Approved and certified according to EC Standard 94/9/EC
- Mounting instructions available at www.ktr.com

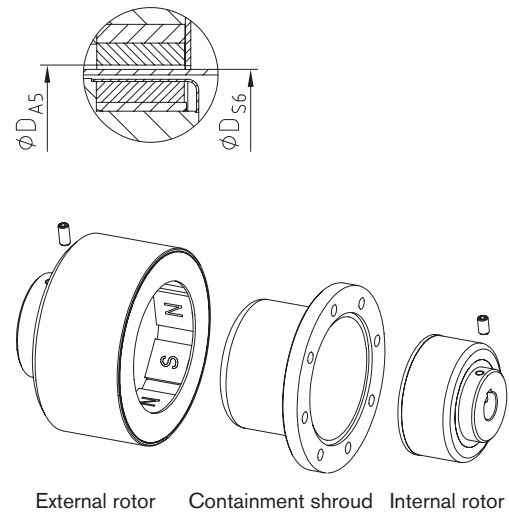
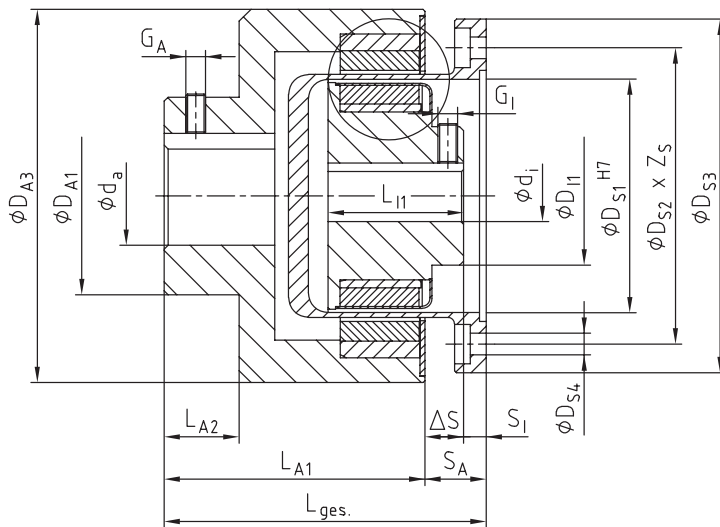

Technical data – Internal rotor and containment shroud													
Size	T_K max. [Nm] with ~ 20 °C	Dimensions [mm]											
		Internal rotor						Containment shroud					
		Finish bore ¹⁾ d_i		D_{I1}	L_{I1}	S_I		G_I	D_{S1}	D_{S2}	D_{S3}	D_{S4}	Z_S
min.	max.	min.	max.										
SA 22/4	0,15	5	9	20	20	2,0	2,0	M3	21,5	38	46	4,5	8
SA 34/10	1	5	12	20	22	2,0	5,5	M3	34	46	55	4,5	4
SA 46/6	3	8	16	28	33	6,5	7,0	M4	46	-	78	-	-
SA 60/8	7	12	22	36	36	2,2	3,5	M5	59	75	89,5	5,5	8
SB 60/8	14			36	56	0,0	3,5						

Technical data – External rotor and general														
Size	Dimensions [mm]													
	External rotor							General						
	Finish bore ¹⁾ d_a		D_{A1}	D_{A3}	L_{A1}	L_{A2}	ΔS	G_A	D_{S6}	D_{A5}	L_{total}			
min.	max.													
SA 22/4	5	11	18	38	35	8,5	5,0	M4	23,5	24,8	42	42		
SA 34/10	5	14	22	53	38,5	10,5	5,5	M4	36,0	37,3	46	49,5		
SA 46/6	5	24	40	69,5	53	16	9,0	M5	48,5	49,4	68,5	69,5		
SA 60/8	9	32	50	94,5	66	19	12,0	M6	61,0	63,2	80	81,3		
SB 60/8	9	38	50	93	15	M8		61,5	63,2	105	108			

¹⁾ Bore H7 with feather keyway DIN 6885 sheet 1 [JS9]

Ordering example:	MINEX® SA 60/8	NdFeB	d_i Ø20mm	d_a Ø24mm
	Coupling size	NdFeB – $t_{max.} = 150$ °C Sm2Co17 – $t_{max.} = 300$ °C	Finish bore (H7) feather keyway to DIN 6885 sheet 1 (JS9)	

Sizes SA 75/10 to SF 250/38 with containment shroud made of stainless steel or Hastelloy

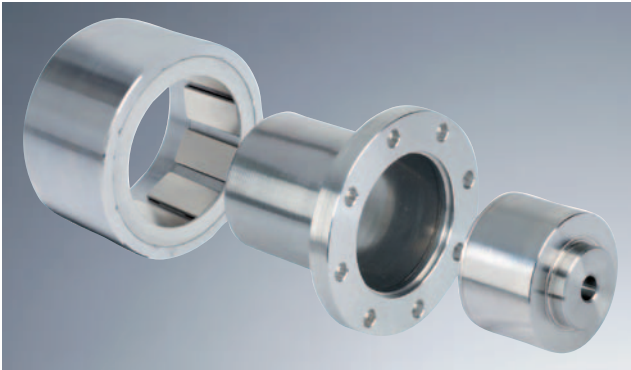

- Contactless torque transmission
- Hermetic separation of driving and driven side
- As an alternative containment shroud made of stainless steel 1.4571 or Hastelloy
- Two-part external rotor with flange hub that must be separately screwed, customer-specific variations are possible
- Available from stock with pilot bored internal rotor
- Finish bore possible to ISO fit H7, feather keyway to DIN 6885 sheet 1 - JS9
- -Approved and certified according to EC Standard 94/9/EC

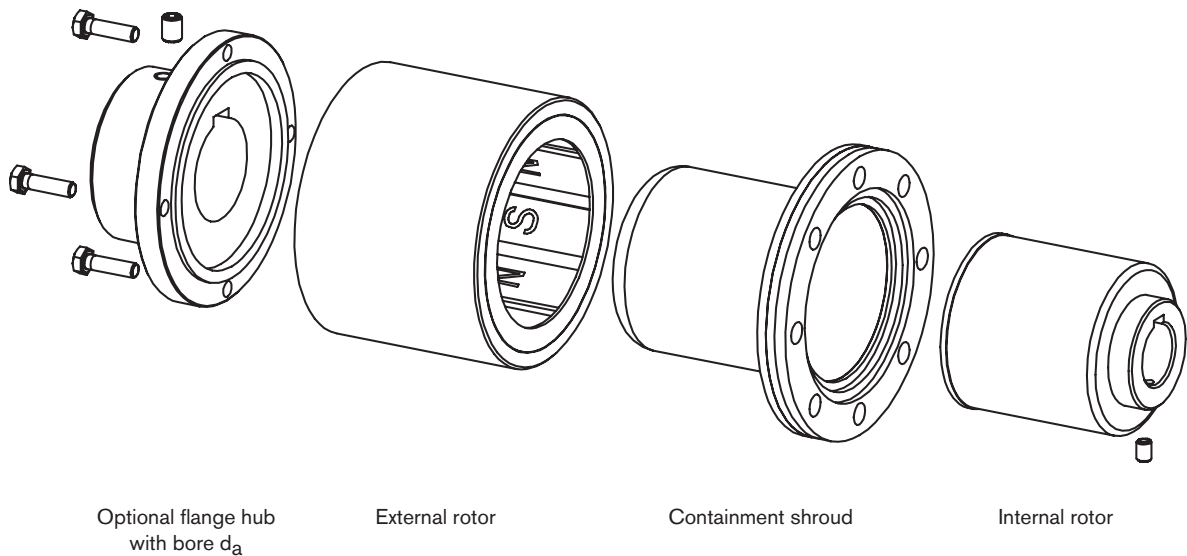
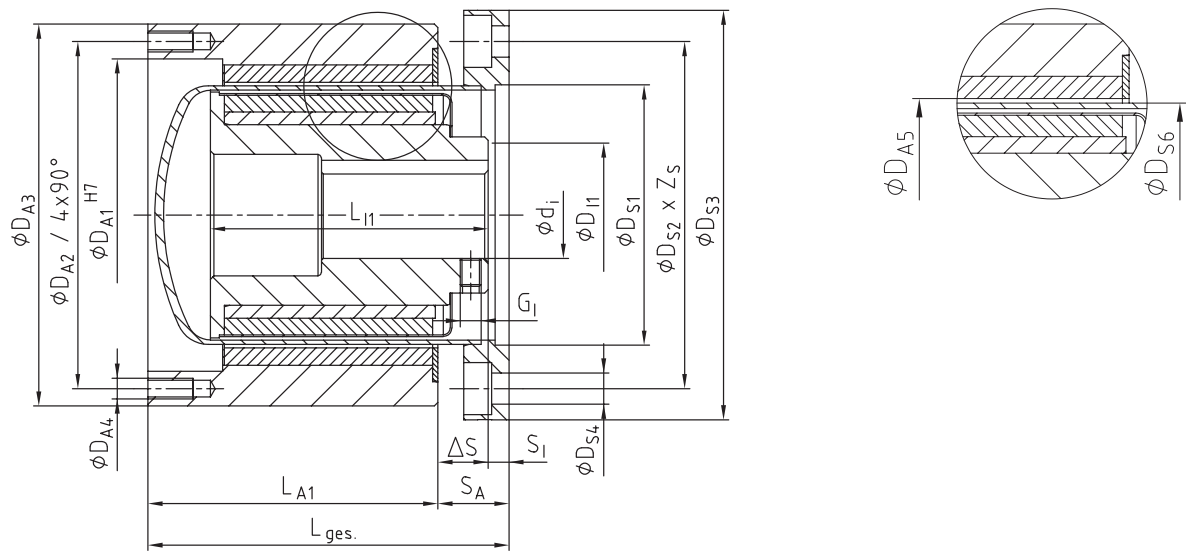

Ordering example:	MINEX® SB 75/10	NdFeB	d _i Ø20mm	d _a Ø24mm	Hastelloy
	Coupling size	NdFeB – t _{max.} = 150 °C Sm ₂ Co ₁₇ – t _{max.} = 300 °C	Finish bore (H7), feather keyway to DIN 6885 sheet 1 (JS9)		Containment shroud type

Technical data – Sizes SA 75/10 to SF 250/38

Technical data – Internal rotor and containment shroud													
Size	TK max. [Nm] with ~ 20 °C	Dimensions [mm]											
		Internal rotor						General					
		Finish bore ¹⁾ d _i		D _{I1}	L _{I1}	S _I		G _I	D _{S1}	D _{S2}	D _{S3}	D _{S4}	Z _S
		min.	max.			min.	max.						
SA 75/10	10				39,5		46,5						
SB 75/10	24	12	32	45	58	4	26,5	M6	75	100	118	9	8
SC 75/10	40				80		6,0						
SA 110/16	25				45		51,0						
SB 110/16	60	14	55	72	65	4	31,0	M8	110	133	153	9	12
SC 110/16	95				85		11,0						
SB 135/20	100				65		46,5						
SC 135/20	145	20	70	90	85	4	26,5	M10	135	158	178	9	16
SD 135/20	200				110		7,0						
SC 165/24	210				85		66,5						
SD 165/24	280	24	90	110	110	6	41,0	M12	163,5	192	218	11	12
SE 165/24	370				130		22,0						
SD 200/30	430	38	90	130	135	6	18,0	M16	200	252	278	11	12
SE 200/30	550												
SD 250/38	670				115		7,0						
SE 250/38	820	38	90	165	135	–	26,0	M16	255	285	315	13,5	12
SF 250/38	1000				155		46,0						

Technical data – External rotor and general									
Size	Dimensions [mm]								
	External rotor						General		
	D _{A1}	D _{A2}	D _{A3}	D _{A4}	L _{A1}	ΔS	D _{S6}	D _{A5}	L _{total}
SA 75/10					41				
SB 75/10	90	100	110	M6	61	12,5	74,6	76,4	102
SC 75/10					83,5	14,5			
SA 110/16					41				
SB 110/16	126	135	145	M6	61	19,0	111,5	113,1	115
SC 110/16					81				
SB 135/20					70				
SC 135/20	150	160	170	M6	90	18,5	136,5	138,5	139
SD 135/20					110	22,0			
SC 165/24					90	18,5			
SD 165/24	150	188	198	M6	110	21,0	167,0	169,2	170
SE 165/24					130				
SD 200/30					130	26,0	198,0	199,5	180
SE 200/30	212	222	232	M6					
SD 250/38					110				
SE 250/38	267	277	287	M6	130	26,0	253,0	255,0	183
SF 250/38					150				

¹⁾ Bore H7 with feather keyway DIN 6885 sheet 1 [JS9]
Further sizes on request.

Sizes SA 75/10 to SE 165/24 with containment shroud made of PEEK

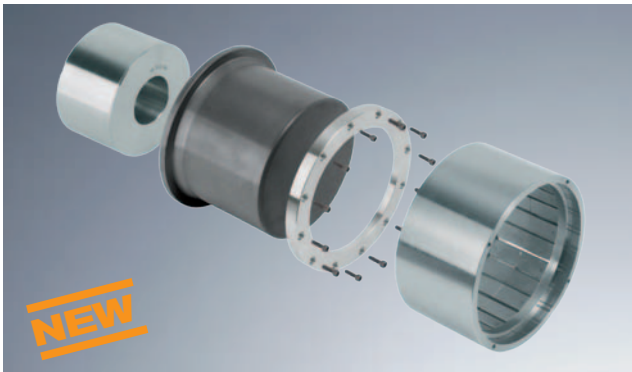

- No eddy current losses and consequently no generation of heat in the coupling caused by the containment shroud
- Low susceptibility to fracture, low weight, easy handling
- Optimal solution with low demands on temperature and pressure resistance (up to 16 bar and 130 °C)
- Internal cooling measures are not required
- High energy efficiency and cost effectiveness
- The selection torque may be reduced by 10 - 15 %
- Suitable for dry-running drives like compressors and vacuum pumps, but also agitators, polyurethane plants, etc.

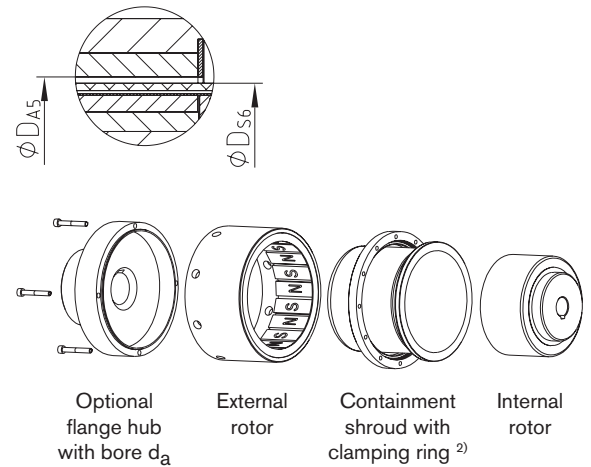
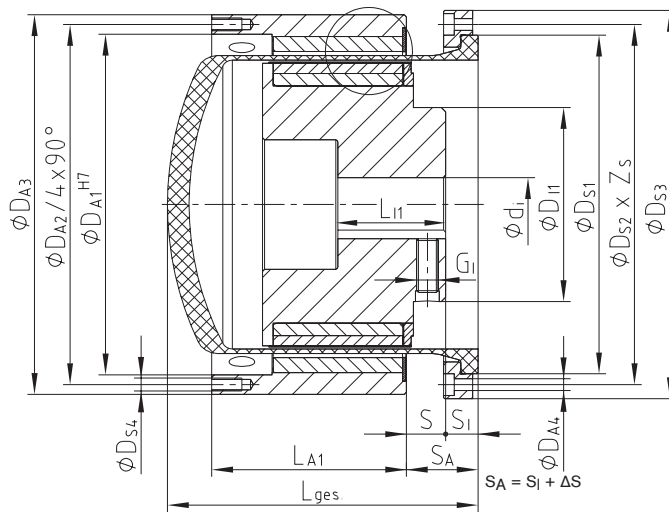

²⁾Containment shroud size 75 also available as a single-parted design!

Technical data – Internal rotor and containment shroud														
Size	TK max. [Nm] with 20 °C	Dimensions [mm]												
		Internal rotor						Containment shroud						
		Finish bore ¹⁾ d _i		D _{I1}	L _{I1}	S _I		G ₁	D _{S1}	D _{S2}	D _{S3}	D _{S4}	D _{S5}	Z _S
min.	max.	min.	max.											
SA 75/10	10				39,5	7,5	54,5							
SB 75/10	24	12	28	45	58	7,5	35,5	M6	100	115	135	9,0	72,1	8
SC 75/10	40				80	5,5	13,5							
SA 110/16	30				45		45,0							
SB 110/16	70	14	55	80	65	4,0	25,0	M8	140	151	168	9,0	109,3	12
SC 110/16	100				85		5,0							
SB 135/20	110				65		48,0							
SC 135/20	155	20	70	90	85	4,0	28,0	M10	157	167	180	5,5	133,9	12
SD 135/20	210				110		4,0							
SC 165/24	220				85		32,0							
SD 165/24	300	24	90	110	110	4,0	8,0	M12	196	210	225	6,6	163,8	12
SE 165/24	390				130	0,0	0,0							

Technical data – External rotor and general										
Size	Dimensions [mm]									
	External rotor					General				
	D _{A1}	D _{A2}	D _{A3}	D _{A4}	L _{A1}	ΔS	D _{S6}	D _{A5}	L _{total}	
SA 75/10					41	12,5				
SB 75/10	90	100	110	M6	61		75,1	76,5	108	
SC 75/10					83,5	14,5				
SA 110/16					41					
SB 110/16	130	138	150	M6	61	19	113,2	115,7	115	
SC 110/16					81					
SB 135/20					70					
SC 135/20	158	167	176	M6	90	18,5	138,2	141,9	144	
SD 135/20					110	21				
SC 165/24					90	18				
SD 165/24	182	191	200	M6	110		168,3	172,0	156	
SE 165/24					130	21			160	

¹⁾ Bore H7 with feather keyway DIN 6885 sheet 1 [JS9]

Ordering example:	MINEX® SB 75/10	NdFeB	d _i Ø20mm	d _a Ø24mm	PEEK
	Coupling size	NdFeB – t _{max.} = 150 °C Sm ₂ Co ₁₇ – t _{max.} = 300 °C	Finish bore (H7), feather keyway to DIN 6885 sheet 1 (JS9)		Containment shroud type

Sizes SA 110/16 to SE 200/30 with containment shroud made of oxide ceramics

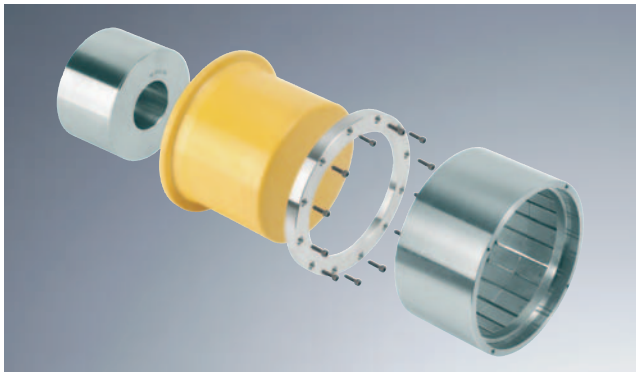

- No eddy current losses and consequently no generation of heat in the coupling caused by the containment shroud
- Suitable for higher demands on temperature and pressure resistance (up to 25 bar and 300 °C)
- Internal cooling measures are usually not required
- High energy efficiency and cost effectiveness
- The selection torque may be reduced by 10 - 15 %
- Suitable for dry-running drives like compressors and vacuum pumps, but also agitators, polyurethane plants, etc.
- Sizes SA 110/16 to SE 200/30 available from stock, other sizes on request
- Approved and certified according to EC Standard 94/9/EC

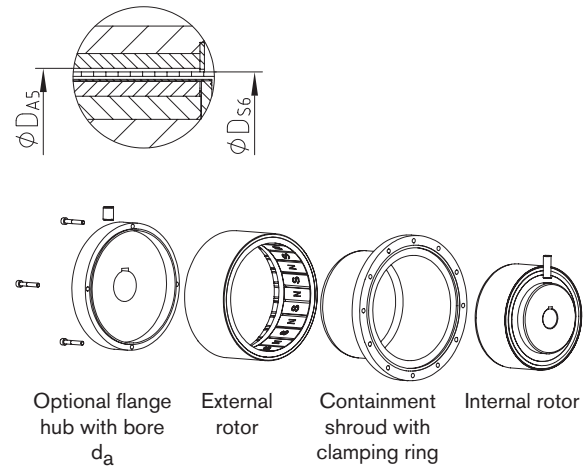
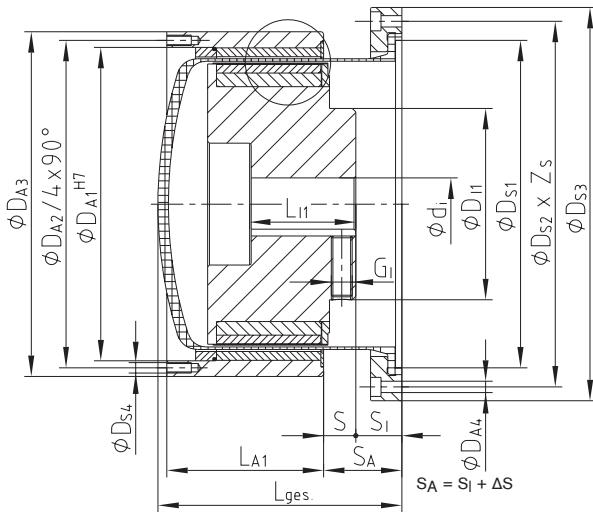

Technical data – Internal rotor and containment shroud													
Size	TK max. [Nm] with ~ 20 °C	Dimensions											
		Internal rotor					Containment shroud						
		Finish bore ¹⁾ d _i		D _{I1}	L _{I1}	S ₁		G ₁	D _{S1}	D _{S2}	D _{S3}	D _{S4}	Z _S
min.	max.	min.	max.										
SA 110/16	25				45		49,0						
SB 110/16	60	14	55	72	65	4,0	29,0	M8	119,5	148	162	5,5	12
SC 110/16	95				85		9,0						
SB 135/20	100				65		46,5						
SC 135/20	145	20	70	90	85	4,0	26,5	M10	145	173	187	5,5	12
SD 135/20	200				110		7,0						
SC 165/24	210				85	3,5	28,0						
SD 165/24	280	24	90	110	110	-	4,0	M12	188	210	226	6,6	12
SE 165/24	370				130	6,0	14,0						
SD 200/30	430												
SE 200/30	550	38	90	130	135	6,0	14,0	M16	242	272	294	9,0	12

Technical data – External rotor and general									
Size	Dimensions [mm]								
	External rotor						General		
	DA1	DA2	DA3	DA4	LA1	ΔS	DS6	DA5	L _{total}
SA 110/16					41				
SB 110/16	126	135	145	M6	61	19,0	111,5	113,1	115
SC 110/16					81				
SB 135/20					70				
SC 135/20	150	160	170	M6	90	18,5	136,5	138,5	139
SD 135/20					110	22,0			
SC 165/24					90	18,5			
SD 165/24	180	188	198	M6	110		167,0	169,2	170
SE 165/24					130	21,0			
SD 200/30									
SE 200/30	212	222	232	M6	130	26,0	198,0	199,5	180

¹⁾ Bore H7 with feather keyway DIN 6885 sheet 1 [JS9]

Ordering example:	MINEX® SB 135/20	NdFeB	d _i Ø20mm	d _a Ø24mm	Oxide ceramics ZrO ₂ MgO
	Coupling size	NdFeB – t _{max.} = 150 °C Sm ₂ Co ₁₇ – t _{max.} = 300 °C	Finish bore (H7), feather keyway to DIN 6885 sheet 1 (JS9)		Containment shroud type

Mounting sets and customized assemblies

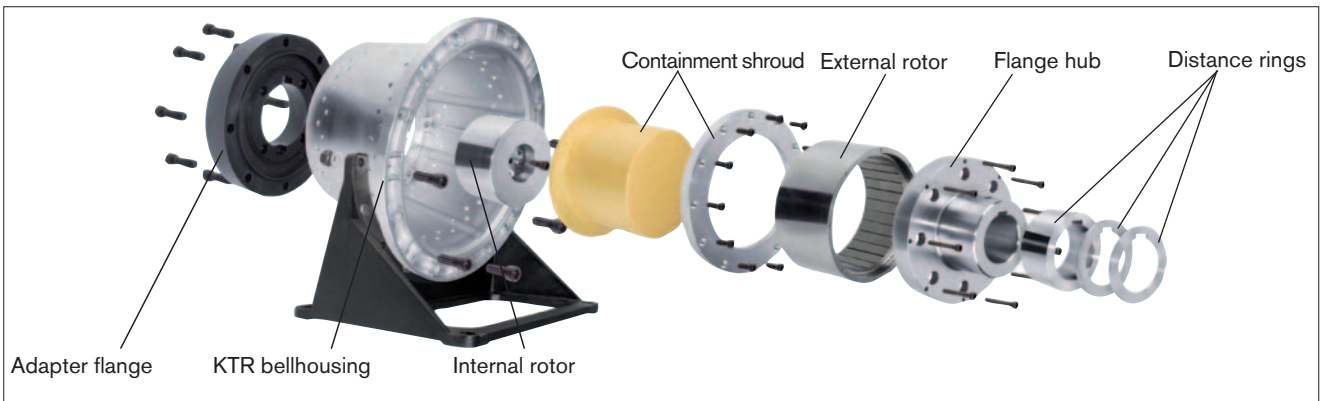

On request KTR can offer special customer-specific solutions in combination with hydraulic components from KTR, whereby existing systems can be easily retrofitted with the MINEX®-S.

Retrofitting sets for PUR foaming processes

Conveying and proportioning the media polyol and isocyanate in the processing plants for PUR, ambient air has to be prevented from penetrating into the process, since otherwise unrequested reactions may be produced.

For a reliable sealing of such drives KTR offers standard sets for retrofitting, among others for axial piston pumps types **REXROTH A2VK** and **ROTARY POWER C series** offering the following benefits:

- Maintenance-free operation
- Standstill periods are considerably reduced
- No more problems with sealing
- Better efficiency and process safety

The assemblies are available for all motor-pump-combinations and in various materials.



Axial piston pump REXROTH type A2VK

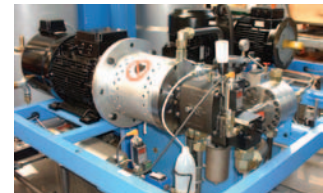

Maintenance-free sealing of dosing pumps for polyde and isocyanate in high-pressure reaction casting machines

Examples of application

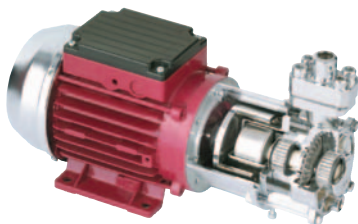

Use of the MINEX®-S in a small centrifugal pump

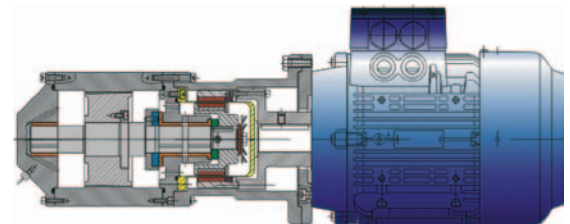

MINEX®-S for sealing homogenizers for heavy oil processing in marine operation



Retrofitting of a gear pump with MINEX® SA 75/10, bellhousing PK 200/30, base flange and damping rod

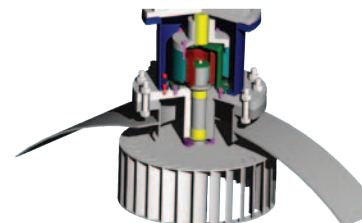

MINEX®-S for the separation of autoclaves (T.B.M./STERICHEM) in laboratories and clinics

Technical data for coupling selection/selection of components

Motor type	_____	Pump type	_____
Power	_____ kW	Speed	_____ rpm
Pressure	_____ bar	Temperature	_____ °C
Viscosity of medium	_____ mm ² /s	Max. perm. dimensions	_____ ØD x L _{total}