



ROTEX®

Torsionally flexible jaw-type couplings

No. 001 – shaft coupling,
No. 018 – DKM,
with taper clamping sleeve
and their combinations

according to directive 94/9/EC
(ATEX 95) for finish bored, pilot
bored and unbored couplings

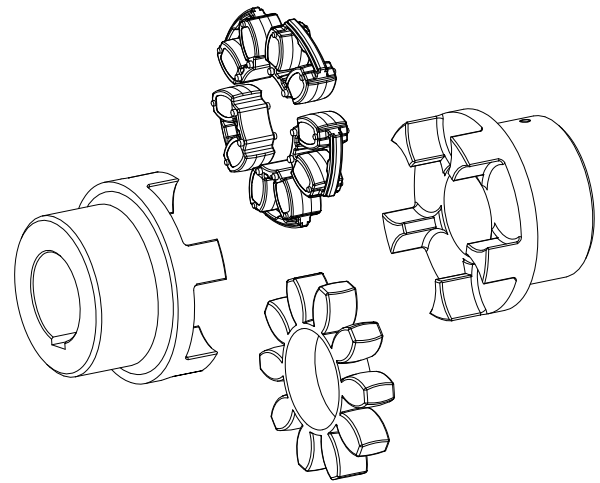

Type No. 001 – shaft coupling

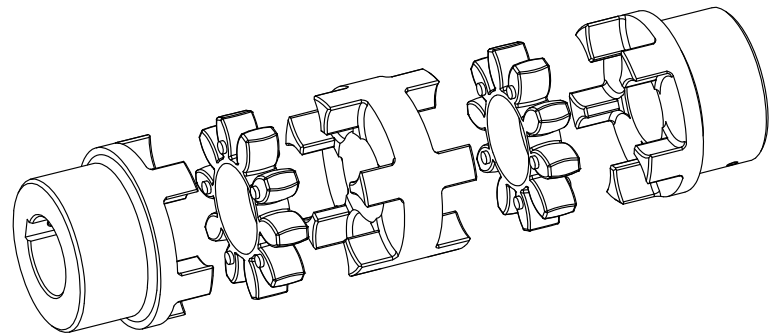

**Type No. 018 – DKM
double-cardanic coupling**

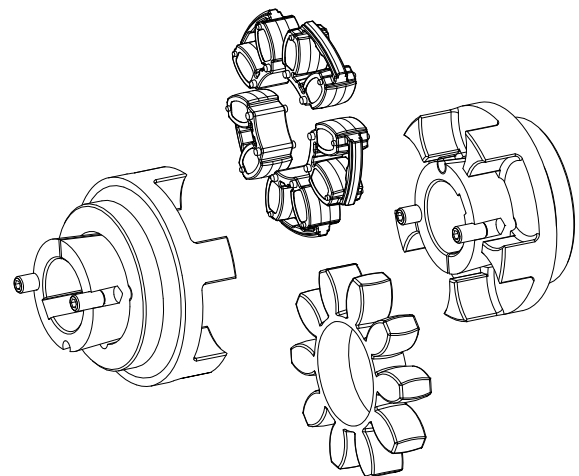

Type with taper clamping sleeve



ROTEX® is a torsionally flexible jaw coupling. It is able to compensate for shaft displacement, for example caused by manufacturing inaccuracies, heat expansion, etc.

Table of contents

1 Technical data

2 Advice

- 2.1 Coupling selection
- 2.2 General advice
- 2.3 Safety and advice symbols
- 2.4 General hazard warnings
- 2.5 Intended use





3 Storage

4 Assembly

- 4.1 Components of the couplings
- 4.2 Advice regarding finish bore
- 4.3 Assembly of the hubs
- 4.4 Assembly of the taper clamping sleeve
- 4.5 Displacements - alignment of the couplings
- 4.6 Spares inventory, customer service addresses

5 Enclosure A

Advice and instructions regarding the use in hazardous areas

- 5.1 Use in  hazardous areas according to the regulations
- 5.2 Inspection intervals for couplings in  hazardous areas
- 5.3 Standard values of wear
- 5.4 Permissible coupling materials in  hazardous areas
- 5.5  marking of coupling for hazardous areas
- 5.6 Start-up
- 5.7 Breakdowns, causes and elimination
- 5.8 EC certificate of conformity according to the EC directive 94/9/EC dated March 23, 1994



1 Technical data

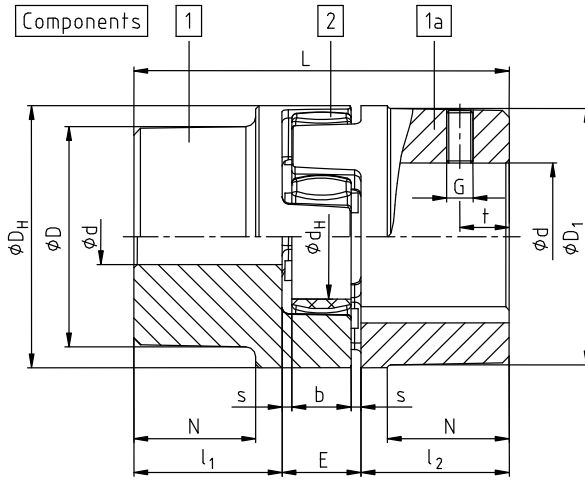

Illustration 1: ROTEX® (material: Al-D)

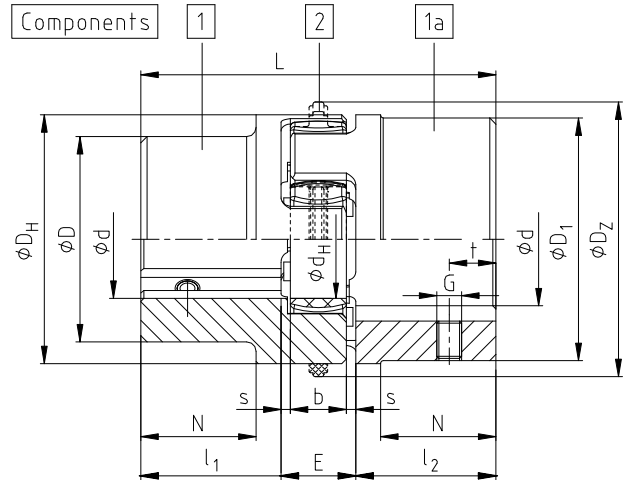

Illustration 2: ROTEX® (material: EN-GJL-250/EN-GJS-400-15)

Table 1: material Al-D

Size	Component	Spider ¹⁾ (component 2) rated torque [Nm]			Finish bore ²⁾ d (min-max)	Dimensions [mm] ³⁾										
		92 Sh A	98 Sh A	64 Sh D		General										
						L	l ₁ ; l ₂	E	b	s	D _H	D _Z	D _{Z1} ⁴⁾	d _H	D;D ₁	N
14	1a	7,5	12,5	-	6 - 16	35	11	13	10	1,5	30	-	-	10	30	-
19	1	10	17	-	6 - 19	66	25	16	12	2	41	-	-	18	32	20
	19 - 24				41											
24	1	35	60	-	9 - 24	78	30	18	14	2	56	-	-	27	40	24
	22 - 28				56											
28	1	95	160	-	10 - 28	90	35	20	15	2,5	67	-	-	30	48	28
	28 - 38				67											

Table 2: material EN-GJL-250 (GG 25)/EN-GJS-400-15 (GGG 40)

Size	Component	Spider ¹⁾ (component 2) rated torque [Nm]			Finish bore ²⁾ d (min-max)	Dimensions [mm] ³⁾										
		92 Sh A	98 Sh A	64 Sh D		General										
						L	l ₁ ; l ₂	E	b	s	D _H	D _Z	D _{Z1} ⁴⁾	d _H	D;D ₁	N
Cast iron EN-GJL-250																
38	1	190	325	405	12 - 40	114	45	24	18	3	80	-	-	38	66	37
	1a				38 - 48										78	
	1b				12 - 48										164	
42	1	265	450	560	14 - 45	126	50	26	20	3	95	-	-	46	75	40
	1a				42 - 55										94	
	1b				14 - 55										176	
48	1	310	525	655	15 - 52	140	56	28	21	3,5	105	-	-	51	85	45
	1a				48 - 62										104	
	1b				15 - 62										188	
55	1	410	685	825	20 - 60	160	65	30	22	4	120	-	-	60	98	52
	1a				55 - 74										118	
65	1	625	940	1175	22 - 70	185	75	35	26	4,5	135	-	-	68	115	61
75	1	1280	1920	2400	30 - 80	210	85	40	30	5	160	-	-	80	135	69
90	1	2400	3600	4500	40 - 97	245	100	45	34	5,5	200	218	230	100	160	81
Nodular iron EN-GJS-400-15																
100	1	3300	4950	6185	50 - 115	270	110	50	38	6	225	246	260	113	180	89
110	1	4800	7200	9000	60 - 125	295	120	55	42	6,5	255	276	290	127	200	96
125	1	6650	10000	12500	60 - 145	340	140	60	46	7	290	315	330	147	230	112
140	1	8550	12800	16000	60 - 160	375	155	65	50	7,5	320	345	360	165	255	124
160	1	12800	19200	24000	80 - 185	425	175	75	57	9	370	400	415	190	290	140
180	1	18650	28000	35000	85 - 200	475	185	85	64	10,5	420	450	465	220	325	156

- 1) Maximum torque of the coupling $T_{Kmax.}$ = rated torque of the coupling $T_{KNenn.} \times 2$
- 2) Bores H7 with keyway to DIN 6885 sheet 1 [JS9] and thread for setscrew
- 3) For dimensions G and t see table 6; threads for setscrews are located opposite the keyway with material Al-D and on the keyway with material EN-GJL-250/EN-GJS-400-15
- 4) D_{Z1} = internal diameter of housing

Please note protection mark ISO 16016.	Drawn:	30.10.12 Pz/Bru	Replaced for:	KTR-N valid from 21.05.10
	Verified:	16.11.12 Pz	Replaced by:	



1 Technical data

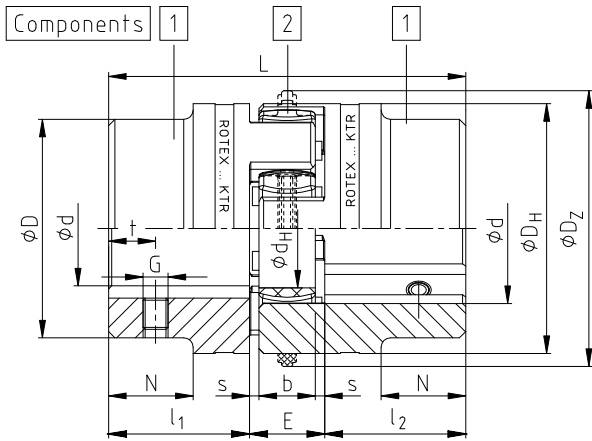

Illustration 3: ROTEX® (material: steel)

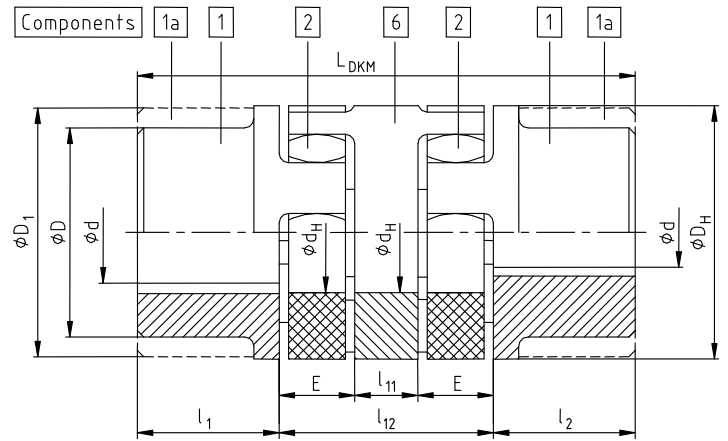

Illustration 4: ROTEX®, type DKM⁵⁾

Table 3: material steel

Size	Component	Spider ¹⁾ (component 2) rated torque [Nm]			Finish bore ²⁾ d (min-max)	Dimensions [mm] ³⁾										
		92 Sh A	98 Sh A	64 Sh D		General										
						L	l ₁ ; l ₂	E	b	s	D _H	D _Z	D _{Z1} ⁴⁾	d _H	D	N
14	1a	7,5	12,5	16	0 - 16	35	11	13	10	1,5	30	-	-	10	30	-
	1b					50	18,5									
19	1a	10	17	21	0 - 25	66	25	16	12	2	40	-	-	18	40	-
	1b					90	37									
24	1a	35	60	75	0 - 35	78	30	18	14	2	55	-	-	27	55	-
	1b					118	50									
28	1a	95	160	200	0 - 40	90	35	20	15	2,5	65	-	-	30	65	-
	1b					140	60									
38	1	190	325	405	0 - 48	114	45	24	18	3	80	-	-	38	70	27
	1b					164	70								80	-
42	1	265	450	560	0 - 55	126	50	26	20	3	95	-	-	46	85	28
	1b					176	75								95	-
48	1	310	525	655	0 - 62	140	56	28	21	3,5	105	-	-	51	95	32
	1b					188	80								105	-
55	1	410	685	825	0 - 74	160	65	30	22	4	120	-	-	60	110	37
	1b					210	90								120	-
65	1	625	940	1175	0 - 80	185	75	35	26	4,5	135	-	-	68	115	47
	1b					235	100								135	-
75	1	1280	1920	2400	0 - 95	210	85	40	30	5	160	-	-	80	135	53
	1b					260	110								160	-
90	1	2400	3600	4500	0 - 110	245	100	45	34	5,5	200	218	230	100	160	62
	1b					295	125								200	-

Table 4: type DKM⁵⁾

Size	Spider ¹⁾ (component 2) rated torque [Nm]		Dimensions d, D, D ₁	Dimensions [mm] ³⁾								
	92 Sh A	98 Sh A		General								
				L _{DKM}	l ₁ ; l ₂	E	b	s	D _H	d _H	l ₁₁	l ₁₂
19	10	17	see table 1 to 3	92	25	16	12	2	40	18	10	42
24	35	60		112	30	18	14	2	55	27	16	52
28	95	160		128	35	20	15	2,5	65	30	18	58
38	190	325		158	45	24	18	3	80	38	20	68
42	265	450		174	50	26	20	3	95	46	22	74
48	310	525		192	56	28	21	3,5	105	51	24	80
55	410	685		218	65	30	22	4	120	60	28	88
65	625	940		252	75	35	26	4,5	135	68	32	102
75	1280	1920		286	85	40	30	5	160	80	36	116
90	2400	3600		330	100	45	34	5,5	200	100	40	130

- 1) Maximum torque of the coupling T_{Kmax.} = rated torque of the coupling T_{K Nenn.} x 2
- 2) Bores H7 with keyway to DIN 6885 sheet 1 (JS9) and thread for setscrew
- 3) For dimensions G and t see table 6; threads for setscrews are located opposite the keyway with material Al-D and on the keyway with material EN-GJL-250/EN-GJS-400-15
- 4) D_{Z1} = internal diameter of housing
- 5) Type DKM not available with DZ elements.

Please note protection mark ISO 16016.	Drawn:	30.10.12 Pz/Bru	Replaced for:	KTR-N valid from 21.05.10
	Verified:	16.11.12 Pz	Replaced by:	



1 Technical data

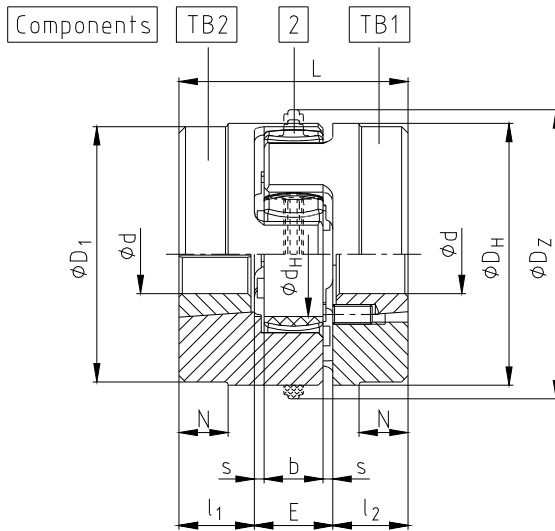

Illustration 5: ROTEX®, type with taper clamping sleeve

Coupling design:

- TB1 Screwing on cam side
- TB2 Screwing on collar side

Different combinations of types TB1 and TB2 are possible.

Table 5: type with taper clamping sleeve

Size	Component	Spider ¹⁾ (component 2) rated torque [Nm]		Finish bore d (min-max)	Dimensions [mm]											Taper clamping sleeve
					General											
					L	l ₁ ; l ₂	E	b	s	D _H	D _Z	D _{Z1} ²⁾	d _H	D ₁	N	
24	1a	35	60	10 - 25	64	23	18	14	2,0	55	-	-	27	-	-	1008
28	1a	95	160	10 - 25	66	23	20	15	2,5	65	-	-	30	-	-	1108
38	1a	190	325	10 - 25	70	23	24	18	3,0	80	-	-	38	78	15	1108
42	1a	265	450	14 - 25	78	26	26	20	3,0	95	-	-	46	94	16	1610
48	1a	310	525	14 - 40	106	39	28	21	3,5	105	-	-	51	104	28	1615
55	1a	410	685	14 - 50	96	33	30	22	4,0	120	-	-	60	118	20	2012
65	1	625	940	14 - 50	101	33	35	26	4,5	135	-	-	68	115	5	2012
75	1	1280	1920	16 - 60 25 - 75	144	52	40	30	5,0	160	-	-	80	158	36	2517 3020 ³⁾
90	1	2400	3600	25 - 75	149	52	45	34	5,5	200	218	230	100	160	14	3020
125	1	6650	10000	35 - 90 55 - 110	240 288	90 114	60	46	7,0	290	315	330	147	230	62 86	3535 4545

- 1) Maximum torque of the coupling $T_{Kmax.}$ = rated torque of the coupling $T_{KNenn.} \times 2$
- 2) D_{Z1} = internal diameter of housing
- 3) Available for type TB 2 only



ROTEX® couplings with attachments that can generate heat, sparks and static charging (e. g. combinations with brake drums, brake disks, overload systems like torque limiters, fans etc.) are not allowed for the use in hazardous areas. A separate analysis must be performed.



2 Advice

2.1 Coupling selection



CAUTION!

For a long-lasting and failure-free operation of the coupling it must be designed according to the selection instructions (according to DIN 740 part 2) for the particular application (see ROTEX® catalogue).

If the operating conditions (performance, speed, modifications on engine and machine) change, the coupling selection must be reviewed again.

Please make sure that the technical data regarding torque refer to the spider only. The transmittable torque of the shaft/hub connection must be reviewed by the customer, and he is responsible for the same.

For drives subject to torsional vibrations (drives with cyclic stress due to torsional vibration) it is necessary to perform a torsional vibration calculation to ensure a reliable selection. Typical drives subject to torsional vibrations are e. g. drives with diesel engines, piston pumps, piston compressors etc. If requested, KTR will perform the coupling selection and the torsional vibration calculation.

2.2 General advice

Please read through these mounting instructions carefully before you start up the coupling. Please pay special attention to the safety instructions!



The ROTEX® coupling is suitable and approved for the use in hazardous areas. When using the coupling in hazardous areas please observe the special advice and instructions regarding safety in enclosure A.

The mounting instructions are part of your product. Please keep them carefully and close to the coupling. The copyright for these mounting instructions remains with KTR Kupplungstechnik GmbH.

2.3 Safety and advice symbols



DANGER!

Danger of injury to persons.



CAUTION!

Damages on the machine possible.



ATTENTION!

Pointing to important items.



WARNING!

Hints concerning explosion protection.



2 Advice

2.4 General hazard warnings



DANGER!

With assembly, operation and maintenance of the coupling it has to be made sure that the entire drive train is secured against accidental switch-on. You can be seriously hurt by rotating parts. Please make absolutely sure to read through and observe the following safety indications.

- All operations on and with the coupling have to be performed taking into account "safety first".
- Please make sure to switch off the power pack before you perform your work.
- Secure the power pack against accidental switch-on, e. g. by providing warning signs at the place of switch-on or removing the fuse for current supply.
- Do not touch the operation area of the coupling as long as it is in operation.
- Please secure the coupling against accidental contact. Please provide for the necessary protection devices and covers.

2.5 Intended use

You may only assemble, operate and maintain the coupling if you

- carefully read through the mounting instructions and understood them
- had technical training
- are authorized by your company

The coupling may only be used in accordance with the technical data (see table 1 to 5 in chapter 1). Unauthorized modifications on the coupling design are not admissible. We will not assume liability for any damage that may arise. In the interest of further development we reserve the right for technical modifications.

The **ROTEX®** described in here corresponds to the technical status at the time of printing of these mounting instructions.

3 Storage

The coupling hubs are supplied in preserved condition and can be stored at a dry and covered place for 6 - 9 months.

The features of the coupling spiders (elastomers) remain unchanged for up to 5 years with favourable stock conditions.



CAUTION!

The storage rooms may not include any ozone-generating devices, like e. g. fluorescent light sources, mercury-vapour lamps or electrical high-voltage appliances.

Humid storage rooms are not suitable.

Please make sure that condensation is not generated. The best relative air humidity is less than 65%.

4 Assembly

Basically the coupling is supplied in individual parts. Before assembly the coupling has to be inspected for completeness.

Please note protection mark ISO 16016.	Drawn:	30.10.12 Pz/Bru	Replaced for:	KTR-N valid from 21.05.10
	Verified:	16.11.12 Pz	Replaced by:	



4 Assembly

4.1 Components of couplings

Components of ROTEX®, shaft coupling type No. 001

Component	Quantity	Designation
1	2	hub
2	1	spider ¹⁾
3	5 ²⁾	DZ elements ¹⁾
4	2	setscrew DIN EN ISO 4029

- 1) Optionally spider or DZ elements
- 2) With size 180 the quantity is 6.

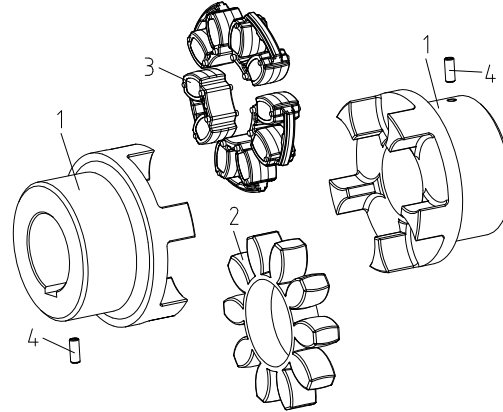

Illustration 6:
ROTEX®

Components of ROTEX®, type DKM ¹⁾

Component	Quantity	Designation
1	2	hub
2	2	spider
3	1	DKM - spacer
4	2	setscrew DIN EN ISO 4029

- 1) Type DKM not available with DZ elements.

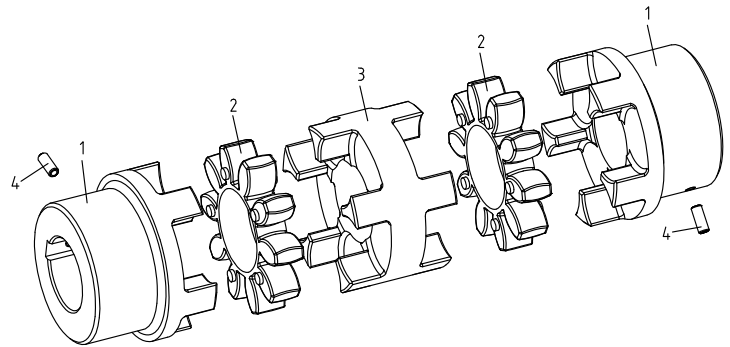

Illustration 7: ROTEX® DKM

Components of ROTEX®, type with taper clamping sleeve

Component	Quantity	Designation
TB1/TB2	2	hub for taper clamping sleeve
1	2	taper clamping sleeve
2	1	spider ¹⁾
3	5 ²⁾	DZ elements ¹⁾
4	4	setscrew DIN EN ISO 4029

- 1) Optionally spider or DZ elements
- 2) With size 180 the quantity is 6.

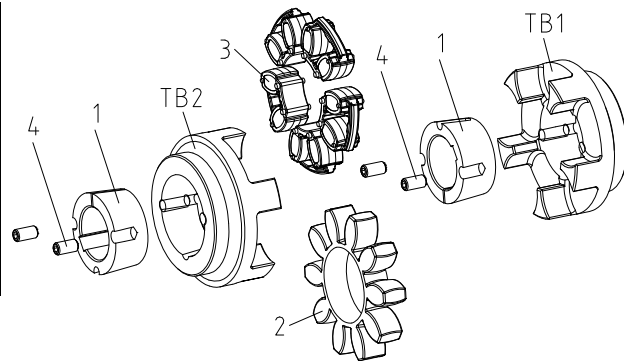

Illustration 8:
ROTEX® type
with taper
clamping
sleeve

Features of the standard spiders

Spider hardness (Shore)	92 Shore-A		95/98 Shore-A		64 Shore-D	
	T-PUR® (orange)	PUR (yellow)	T-PUR® (purple)	PUR (red)	T-PUR® (light green)	PUR (natural white ¹⁾)
Marking (colour)						

- 1) Natural white with green marking of teeth

Please note protection mark ISO 16016.	Drawn:	30.10.12 Pz/Bru	Replaced for:	KTR-N valid from 21.05.10
	Verified:	16.11.12 Pz	Replaced by:	



4 Assembly

4.2 Advice regarding finish bore



DANGER!

The maximum permissible bore diameters d (see table 1 to 5 in chapter 1 - technical data) must not be exceeded. If these figures are disregarded, the coupling may tear. Rotating particles may cause danger to life.

- Hub bores machined by the customer have to observe concentricity or axial runout, respectively (see illustration 9).
- Please make absolutely sure to observe the figures for $\varnothing d_{max}$.
- Carefully align the hubs when the finish bores are drilled.
- Please use a setscrew according to DIN EN ISO 4029 with a cup point or an end plate to fasten the hubs axially.

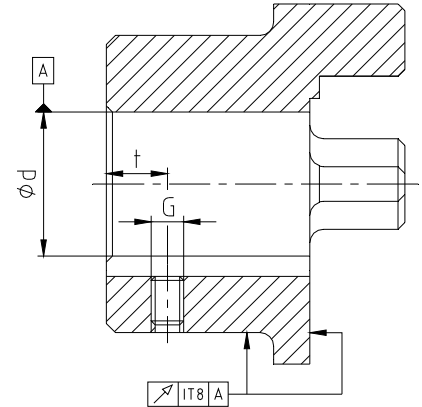

Illustration 9: concentricity and axial runout



CAUTION!

The customer bears the sole responsibility for all machining processes performed subsequently on unbored or pilot bored as well as finish machined coupling components and spare parts. KTR does not assume any warranty claims resulting from insufficient refinishing.



WARNING!

KTR supplies unbored or pilot bored coupling components and spare parts only upon explicit request of the customer. These parts are additionally labelled with the symbol

Table 6: setscrews DIN EN ISO 4029

Size	14	19	24	28	38	42	48	55	65	75	90	100	110	125	140	160	180
Dimension G	M4	M5	M5	M8	M8	M8	M8	M10	M10	M10	M12	M12	M16	M16	M20	M20	M20
Dimension t	5	10	10	15	15	20	20	20	20	25	30	30	35	40	45	50	50
Tightening torque T_A [Nm]	1,5	2	2	10	10	10	10	17	17	17	40	40	80	80	140	140	140

Table 7: Recommended fit pairs acc. to DIN 748/1

Bore [mm]		Shaft tolerance	Bore tolerance
above	up to		
	50	k6	H7
50		m6	(KTR standard)

If a feather key is intended to be used in the hub, it should correspond to the tolerance ISO JS9 (KTR standard) with normal operating conditions or ISO P9 with heavy operating conditions (frequently alternating torsional direction, shock loads, etc.). The keyway should preferably be positioned between the cams. For the axial fastening by setscrews the tapping should be located on the keyway with the exception of AI-D which should be located opposite to the keyway.

The transmittable torque of the shaft/hub connection must be reviewed by the customer, and he is responsible for the same.

Please note protection mark ISO 16016.	Drawn:	30.10.12 Pz/Bru	Replaced for:	KTR-N valid from 21.05.10
	Verified:	16.11.12 Pz	Replaced by:	



4 Assembly

4.3 Assembly of the hubs



ATTENTION!

We recommend to inspect bores, shaft, keyway and feather key for dimensional accuracy before assembly.

Heating the hubs lightly (approx. 80 °C) allows for an easier mounting on the shaft.



WARNING!

Please pay attention to the ignition risk in hazardous areas.



DANGER!

Touching the heated hubs causes burns.
We would recommend to wear safety gloves.



CAUTION!

With the assembly please make sure that the distance dimension E (see table 1 to 5) is observed to allow for axial clearance of the coupling when in operation.
Disregarding this advice may cause damage to the coupling.

- Assemble the hubs on the shaft of driving and driven side (see illustration 10).
- Insert the spider or DZ elements into the cam section of the drive- or driven sided hub.
- Move the power packs in axial direction until the distance dimension E is achieved (see illustration 11).
- If the power packs are already firmly assembled, axial movement of the hubs on the shafts allows for adjusting the distance dimension E.
- Fasten the hubs by tightening the setscrews DIN EN ISO 4029 with cup point (tightening torque see table 6).



ATTENTION!

If the shaft diameters with inserted feather key are smaller than the dimension d_H (see table 1 to 5) of the spider, one or two shaft ends may protude into the spider.

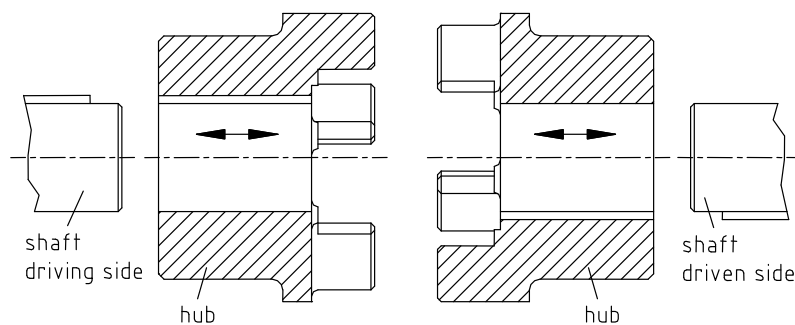

Illustration 10: assembly of the hubs

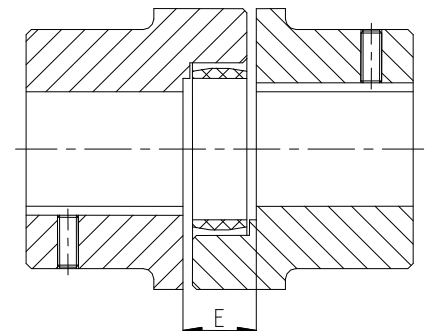

Illustration 11: coupling assembly



4 Assembly

4.4 Assembly of the taper clamping sleeve

Assembly of the taper clamping sleeve:

Clean the contact surfaces of the taper clamping sleeves and of shaft and hub and afterwards apply thin fluid oil lightly (e. g. Ballistol Universal oil or Klüber Quietsch-Ex).
The taper clamping sleeve has axially parallel, cylindrical and smooth blind holes. Only half of these holes are located in the material of the sleeve. The other half located in the hub has threads.
Fit the coupling element and the taper clamping sleeve into each other, make sure that the bores cover each other and tighten the setscrews slightly. Fit the coupling element along with the taper clamping sleeve on the shaft and tighten the setscrews at the tightening torque indicated in table 8.
During the screwing-on process the hub is mounted onto the taper sleeve and thus the sleeve is pressed onto the shaft. By light blows of the hammer the taper clamping sleeve must be pushed further into the taper bore by means of a suitable sleeve. Afterwards please tighten the setscrews again at the tightening torque indicated in table 8. This process must be performed at least once.
After the drive has operated under load for a short while please inspect if the setscrews have unscrewed. An axial fixing of the taper lock hub (coupling hub with taper clamping sleeve) is only obtained by a proper assembly.



CAUTION!

If used in hazardous areas the setscrews must be additionally secured against loosening to fix the taper clamping sleeves, e. g. glueing with Loctite (medium strength).
The use of taper clamping sleeves without a feather key is not permitted in hazardous areas.



CAUTION!

Oils and greases with molybdenum disulphide or high-pressure additives, additives of Teflon and silicone as well as sliding grease paste reducing the coefficient of friction significantly must not be used.

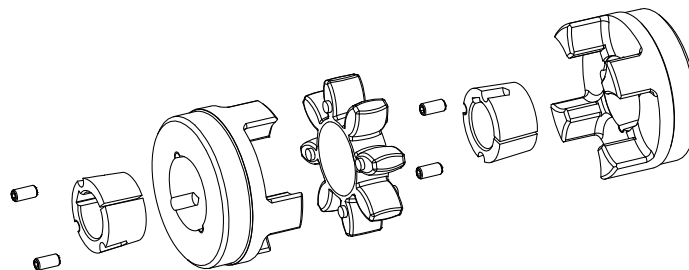

Illustration 12: ROTEX® type with taper clamping sleeve

Disassembly of the taper clamping sleeve:

The taper clamping sleeve is released by removing the setscrews. Afterwards one of the setscrews is screwed in the thread of the sleeve as forcing screw and tightened.
The coupling hub detached in this way can be manually removed from the shaft with the taper clamping sleeve.

Table 8:

Taper clamping sleeve	Screw dimensions				Quantity
	G [inch]	L [inch]	SW [mm]	T _A [Nm]	
1008	1/4	1/2	3	5,7	2
1108	1/4	1/2	3	5,7	2
1610	3/8	5/8	5	20	2
1615	3/8	5/8	5	20	2
2012	7/16	7/8	6	31	2
2517	1/2	7/8	6	49	2
3020	5/8	1 1/4	8	92	2
3535	1/2	1 1/2	10	115	3
4545	3/4	1 3/4	12	170	3

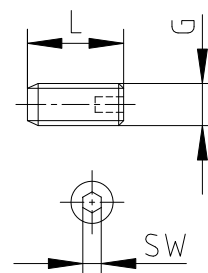

Illustration 13: Withworth setscrew (BSW)

Please note protection mark ISO 16016.	Drawn:	30.10.12 Pz/Bru	Replaced for:	KTR-N valid from 21.05.10
	Verified:	16.11.12 Pz	Replaced by:	



4 Assembly

4.5 Displacements - alignment of the couplings

The displacement figures shown in tables 9 to 11 provide for sufficient safety to compensate for external influences like, for example, heat expansion or foundation settling.



CAUTION!

In order to ensure a long service life of the coupling and avoid dangers with the use in hazardous areas, the shaft ends must be accurately aligned.



Please absolutely observe the displacement figures indicated (see tables 9 to 11). If the figures are exceeded, the coupling will be damaged.

The more accurate the alignment of the coupling, the longer is its service life.

If used in hazardous areas for the explosion group IIC (marking II 2GD c IIC T X), only half of the displacement figures (see tables 9 to 11) are permissible.

Please note:

- The displacement figures mentioned in tables 9 to 11 are maximum figures which must not occur in parallel. If radial and angular displacements occur at the same time, the permissible displacement values may only be used proportionally (see illustration 15).
- Please inspect with a dial gauge, ruler or feeler whether the permissible displacement figures of tables 9 to 11 can be observed.

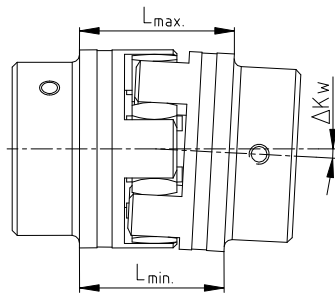

angular displacements

$$\Delta K_w = L_{1max} - L_{1min} \quad [mm]$$

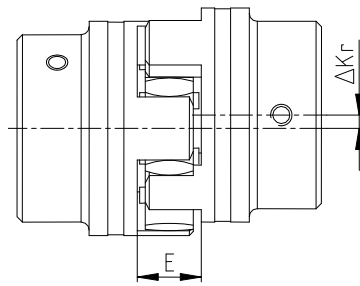

radial displacements

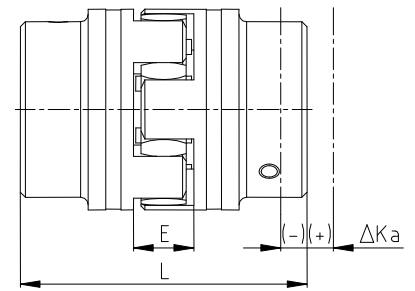

axial displacements

$$L_{max} = L + \Delta K_a \quad [mm]$$

Illustration 14: displacements

Examples for the displacement combinations given in illustration 15:

Example 1:
 $\Delta K_r = 30 \%$
 $\Delta K_w = 70 \%$

Example 2:
 $\Delta K_r = 60 \%$
 $\Delta K_w = 40 \%$

$$\Delta K_{total} = \Delta K_r + \Delta K_w \leq 100 \%$$

Illustration 15:
combinations of
displacement

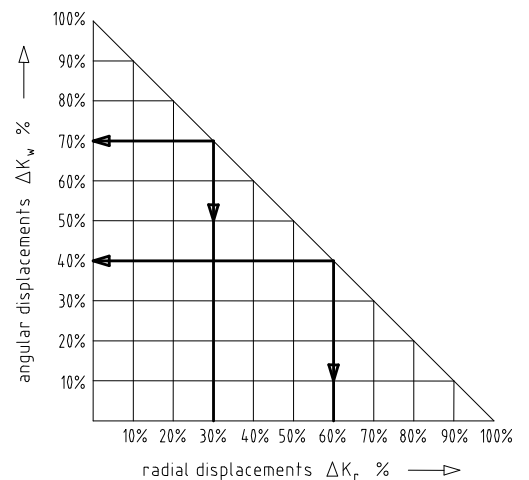



4 Assembly

4.5 Displacements - alignment of the couplings

Table 9: displacement figures for 92 and 95/98 Shore-A

ROTEX® size		14	19	24	28	38	42	48	55	65	75	90	100	110	125	140	160	180
Max. axial displacement ΔK_a [mm]		-0,5	-0,5	-0,5	-0,7	-0,7	-1,0	-1,0	-1,0	-1,0	-1,5	-1,5	-1,5	-2,0	-2,0	-2,0	-2,5	-3,0
		+1,0	+1,2	+1,4	+1,5	+1,8	+2,0	+2,1	+2,2	+2,6	+3,0	+3,4	+3,8	+4,2	+4,6	+5,0	+5,7	+6,4
Max. radial displacement ΔK_r [mm] with	1500 rpm	0,17	0,20	0,22	0,25	0,28	0,32	0,36	0,38	0,42	0,48	0,50	0,52	0,55	0,60	0,62	0,64	0,68
	3000 rpm	0,11	0,13	0,15	0,17	0,19	0,21	0,25	0,26	0,28	0,32	0,34	0,36	0,38	-	-	-	-
ΔK_w [degree] max. angular displacement with n = 1500 rpm ΔK_w [mm]		1,2	1,2	0,9	0,9	1,0	1,0	1,1	1,1	1,2	1,2	1,2	1,2	1,3	1,3	1,2	1,2	1,2
		0,67	0,82	0,85	1,05	1,35	1,70	2,00	2,30	2,70	3,30	4,30	4,80	5,60	6,50	6,60	7,60	9,00
Kw [degree] max. angular displacement with n = 3000 rpm ΔK_w [mm]		1,1	1,1	0,8	0,8	0,9	0,9	1,0	1,0	1,1	1,1	1,1	1,1	1,2	-	-	-	-
		0,60	0,70	0,75	0,85	1,10	1,40	1,60	2,00	2,30	2,90	3,80	4,20	5,00	-	-	-	-

Table 10: displacement figures for 64 Shore-D

ROTEX® size		14	19	24	28	38	42	48	55	65	75	90	100	110	125	140	160	180
Max. axial displacement ΔK_a [mm]		-0,5	-0,5	-0,5	-0,7	-0,7	-1,0	-1,0	-1,0	-1,0	-1,5	-1,5	-1,5	-2,0	-2,0	-2,0	-2,5	-3,0
		+1,0	+1,2	+1,4	+1,5	+1,8	+2,0	+2,1	+2,2	+2,6	+3,0	+3,4	+3,8	+4,2	+4,6	+5,0	+5,7	+6,4
Max. radial displacement ΔK_r [mm] with	1500 rpm	0,11	0,13	0,15	0,18	0,21	0,23	0,25	0,27	0,30	0,34	0,36	0,37	0,40	0,43	0,45	0,46	0,49
	3000 rpm	0,08	0,09	0,1	0,13	0,15	0,16	0,18	0,19	0,21	0,24	0,25	0,26	0,28	-	-	-	-
ΔK_w [degree] max. angular displacement with n = 1500 rpm ΔK_w [mm]		1,1	1,1	0,8	0,8	0,9	0,9	1,0	1,0	1,1	1,1	1,1	1,1	1,2	1,2	1,1	1,1	1,1
		0,57	0,77	0,77	0,90	1,25	1,40	1,80	2,00	2,50	3,00	3,80	4,30	5,30	6,00	6,10	7,10	8,00
Kw [degree] max. angular displacement with n = 3000 rpm ΔK_w [mm]		1,0	1,0	0,7	0,7	0,8	0,8	0,9	0,9	1,0	1,0	1,0	1,0	1,1	-	-	-	-
		0,52	0,7	0,67	0,80	1,00	1,30	1,60	1,80	2,20	2,70	3,50	4,00	4,90	-	-	-	-

Table 11: displacement figures for type DKM only

ROTEX® size		19	24	28	38	42	48	55	65	75	90
Max. axial displacement ΔK_a [mm]		+1,2	+1,4	+1,5	+1,8	+2,0	+2,1	+2,2	+2,6	+3,0	+3,4
		-1,0	-1,0	-1,4	-1,4	-2,0	-2,0	-2,0	-2,0	-3,0	-3,0
Max. radial displacement ΔK_r [mm] with n =	1500 rpm	0,45	0,59	0,66	0,77	0,84	0,91	1,01	1,17	1,33	1,48
	3000 rpm	0,40	0,53	0,60	0,70	0,75	0,82	0,81	1,05	1,19	1,33
ΔK_w [degree] max. angular displacement with n =	1500 rpm	1,0	1,0	1,0	1,0	1,0	1,0	1,0	1,0	1,0	1,0
	3000 rpm	0,9	0,9	0,9	0,9	0,9	0,9	0,9	0,9	0,9	0,9

4.6 Spares inventory, customer service addresses

A basic requirement to ensure the operational readiness of the coupling is a stock of the most important spare parts on site.

Contact addresses of the KTR partners for spare parts and orders can be obtained from the KTR homepage at www.ktr.com.



ATTENTION!

KTR does not assume any liability or warranty for the use of spare parts and accessories which are not provided by KTR and for the damages which may incur as a result.

Please note protection mark ISO 16016.	Drawn:	30.10.12 Pz/Bru	Replaced for:	KTR-N valid from 21.05.10
	Verified:	16.11.12 Pz	Replaced by:	



5 Enclosure A

Advice and instructions regarding the use in hazardous areas

Type 001: hub / spider / hub or hub / DZ elements / hub
 Type 018: hub / spider / DKM spacer / spider / hub
 Type with taper clamping sleeve: hub / taper clamping sleeve / spider / taper clamping sleeve / hub or
 hub / taper clamping sleeve / DZ elements / taper clamping sleeve / hub
(Use of taper clamping sleeve only in combination with a feather key!)

ROTEX® DKM and ROTEX® ZS-DKM only with spacer made of steel or aluminium semi-finished products with a yield point of $R_{p0,2} \geq 250 \text{ N/mm}^2$.

5.1 Use in hazardous areas according to the regulations

Conditions of operation in hazardous locations

ROTEX® couplings are suitable for the use according to EC directive 94/9/EC.

1. Industry (with the exception of mining)

- Equipment group II of category 2 and 3 (*coupling is not approved for equipment group 1*)
- Media class G (*gases, fogs, steams*), zone 1 and 2 (*coupling is not approved for zone 0*)
- Media class D (*dusts*), zone 21 and 22 (*coupling is not approved for zone 20*)
- Explosion group IIC (*explosion class IIA and IIB are included in IIC*)

Temperature class:

T-PUR®			PUR		
Temperature class	Ambient or operating temperature T_a	Max. surface temperature	Temperature class	Ambient or operating temperature T_a	Max. surface temperature
T3, T2, T1	- 50 °C to + 120 °C ¹⁾	+ 140 °C ²⁾	T4, T3, T2, T1	- 30 °C to + 90 °C ¹⁾	110 °C ²⁾
T4	- 50 °C to + 115 °C	+ 135 °C	T5	- 30 °C to + 80 °C	100 °C
T5	- 50 °C to + 80 °C	+ 100 °C	T6	- 30 °C to + 65 °C	85 °C
T6	- 50 °C to + 65 °C	+ 85 °C			

Explanation:

The maximum surface temperatures result from each the maximum permissible ambient or operating temperature T_a plus the maximum temperature increase ΔT of 20 K which has to be taken into account.

- 1) The ambient or operating temperature T_a is limited to + 90 °C (valid for T-PUR® only: + 120 °C) due to the permissible permanent operating temperature of the elastomers used.
- 2) The maximum surface temperature of + 110 °C (valid for T-PUR® only: + 140 °C) applies for the use in locations which are potentially subject to dust explosion, too.

2. Mining

Equipment group I of category M2 (coupling is not approved for equipment group M1).
 Permissible ambient temperature - 30 °C to + 90 °C (valid for T-PUR® only: - 50 °C to + 120 °C).

Please note protection mark ISO 16016.	Drawn:	30.10.12 Pz/Bru	Replaced for:	KTR-N valid from 21.05.10
	Verified:	16.11.12 Pz	Replaced by:	



5 Enclosure A

Advice and instructions regarding the use in  hazardous areas

5.2 Inspection intervals for couplings in  hazardous areas

Explosion group	Inspection intervals
3G 3D	For couplings which are classified in category 3G or 3D the operating and assembly instructions that are usual for standard operation apply. During the standard operation which has to be subject to the ignition risk analysis the couplings are free from any ignition source. Merely the temperature increase produced by self-heating and depending on the coupling type has to be considered: for ROTEX®: $\Delta T = 20 \text{ K}$
II 2GD c IIB T4, T5, T6	An inspection of the circumferential backlash and a visual inspection of the flexible spider/ DZ elements must be performed after 3,000 operating hours for the first time, at the latest after 6 months after start-up of the coupling. If you note insignificant or no wear on the spider/ DZ elements upon this initial inspection, further inspections can each be performed after 6,000 operating hours or at the latest after 18 months, provided that the operating parameters remain the same. If you note significant wear during the initial inspection, so that it would be recommendable to replace the spider/DZ elements, please find out the cause according to the table „Breakdowns“, if possible. The maintenance intervals must definitely be adjusted to the modified operating parameters.
II 2GD c IIC T4, T5, T6	An inspection of the circumferential backlash and a visual inspection of the flexible spider/ DZ elements must be performed after 2,000 operating hours for the first time, at the latest after 3 months after start-up of the coupling. If you note insignificant or no wear on the spider/DZ elements upon this initial inspection, further inspections can each be performed after 4,000 operating hours or at the latest after 12 months, provided that the operating parameters remain the same. If you note significant wear during the initial inspection, so that it would be recommendable to replace the spider/DZ elements, please find out the cause according to the table „Breakdowns“, if possible. The maintenance intervals must definitely be adjusted to the modified operating parameters.

ROTEX® coupling

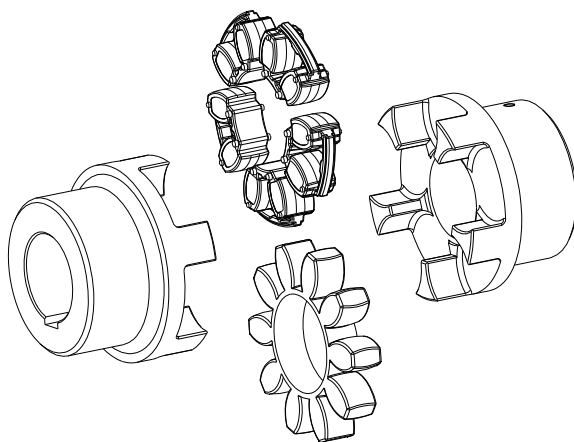

Illustration 16: ROTEX® coupling

Illustration 17.1:
ROTEX®
DZ elements

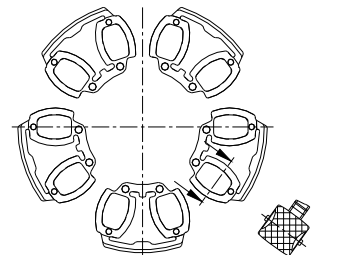
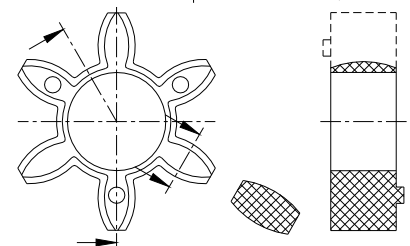

Illustration 17.2:
ROTEX®
spider



Here the backlash between the cams of the coupling and the flexible spider/ DZ element must be inspected by means of a feeler gauge.

When reaching the wear limit **maximum friction**, the spider/ DZ element must be replaced immediately, irrespective of the inspection intervals.

Please note protection mark ISO 16016.	Drawn:	30.10.12 Pz/Bru	Replaced for:	KTR-N valid from 21.05.10
	Verified:	16.11.12 Pz	Replaced by:	



5 Enclosure A

Advice and instructions regarding the use in  hazardous areas

5.3 Standard values of wear

In case of a backlash > X mm, the flexible spider/ DZ elements must be replaced.

Reaching the replacement limits depends on the operating conditions and the existing operating parameters.



CAUTION!

In order to ensure a long service life of the coupling and avoid dangers with the use in hazardous areas, the shaft ends must be accurately aligned. Please absolutely observe the displacement figures indicated (see tables 9 to 11). If the figures are exceeded, the coupling will be damaged.

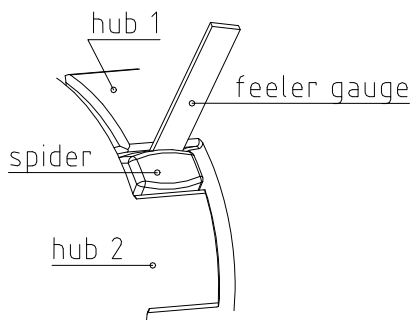

Illustration 18: inspection of the limit of wear

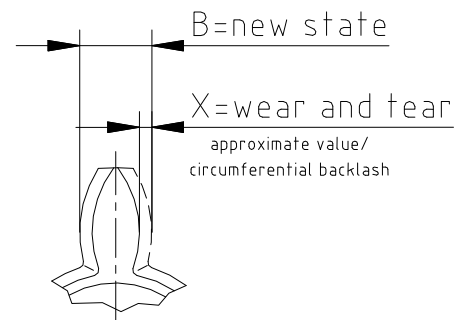

Illustration 19: wear of spider

Table 12:

ROTEX® size	Wear limits (friction)		ROTEX® size	Wear limits (friction)	
	X _{max.} [mm]			X _{max.} [mm]	
9	2		65	5	
14	2		75	6	
19	3		90	8	
24	3		100	9	
28	3		110	9	
38	3		125	10	
42	4		140	12	
48	4		160	14	
55	5		180	14	

5.4 Permissible coupling materials in hazardous areas

In the explosion groups **IIA**, **IIB** and **IIC** the following materials may be combined:

EN-GJL-250 (GG 25)
EN-GJS-400-15 (GGG 40)
steel
stainless steel

Semifinished products from aluminium with a magnesium share of up to 7.5 % and a yield point of $R_{p0.2} \geq 250 \text{ N/mm}^2$ are permitted for the use in hazardous areas.

Aluminium diecast is generally excluded for hazardous areas.

Please note protection mark ISO 16016.	Drawn:	30.10.12 Pz/Bru	Replaced for:	KTR-N valid from 21.05.10
	Verified:	16.11.12 Pz	Replaced by:	



5 Enclosure A

Advice and instructions regarding the use in  hazardous areas

5.5 marking of coupling for hazardous areas

Couplings for the use in hazardous areas are marked on at least one component completely and on the remaining components by an  label on the outside diameter of the hub or on the front side each for the operating conditions permitted. The flexible spider or DZ element is excluded.

For reason of the limited space only the symbol  is stamped up to size 19.

Short labelling:
(standard)



II 2GD c IIC T X/I M2 c X

Complete labelling:
(valid for T-PUR® only)





II 2G c IIC T6, T5, T4 resp. T3 - $50\text{ °C} \leq T_a \leq +65\text{ °C}$, + 80 °C, + 115 °C
resp. + 120 °C
II 2D c T 140 °C/I M2 c - $50\text{ °C} \leq T_a \leq +120\text{ °C}$

Complete labelling:
(valid for PUR only)



II 2G c IIC T6, T5 resp. T4 - $30\text{ °C} \leq T_a \leq +65\text{ °C}$, + 80 °C resp. +90 °C
II 2D c T 110 °C/I M2 c - $30\text{ °C} \leq T_a \leq +90\text{ °C}$

The labelling with explosion group IIC includes the explosion groups IIA and IIB.

If the symbol  was stamped in addition to , the coupling component was supplied unbored or pilot bored by KTR.

5.6 Start-up

Before start-up of the coupling, please inspect the tightening of the setscrews in the hubs, the alignment and the distance dimension E and adjust, if necessary, and also inspect all screw connections regarding the tightening torques specified, dependent on the type of coupling.



If used in hazardous areas the setscrews to fasten the hubs as well as all screw connections must be additionally secured against loosening, e. g. glueing with Loctite (medium strength).

Finally, the coupling protection against accidental contact must be fitted.

The cover must be electrically conductive and be included in the equipotential bonding. Bellhousings (magnesium share below 7.5 %) made of aluminium and damping rings (NBR) can be used as connecting element between pump and electric motor. The cover may only be taken off after having stopped the unit.

During operation of the coupling, please pay attention to

- different operating noise
- vibrations occurring.

If the couplings are used in areas subject to dust explosion and in mining the user must make sure that there is no accumulation of dust in a dangerous volume between the cover and the coupling. The coupling must not operate in an accumulation of dust.

For covers with unlocked openings on the top face no light metals may be used if the couplings are used as equipment of equipment group II (*if possible, from stainless steel*).

If the couplings are used in mining (equipment group I M2), the cover must not be made of light metal. In addition, it must be resistant to higher mechanical loads than if it is used as equipment of equipment group II.



5 Enclosure A

Advice and instructions regarding the use in  hazardous areas

5.6 Start-up

The minimum distance „Sr“ between the protection device and the rotating parts must at least correspond to the figures mentioned below.

If the protection device is used as cover, regular openings complying with the explosion protection demands can be made that must not exceed the following dimensions:

Openings	Cover [mm]		
	Top side	Lateral components	Distance „Sr“
Circular - max. diameter	4	8	≥ 10
Rectangular - max. lateral length	4	8	≥ 10
Straight or curved slot - max. lateral length/height	prohibited	8	≥ 20



CAUTION!

If you note any irregularities on the coupling during operation, the drive unit must be switched off immediately. The cause of the breakdown must be found out by means of the table „Breakdowns“ and if possible, be eliminated according to the proposals. The potential breakdowns mentioned can be hints only. To find out the cause all operating factors and machine components must be considered.

Coupling coating:



If coated (priming, painting etc.) couplings are used in hazardous areas, the requirements to conductivity and coating thickness must be considered. In case of paintings up to 200 µm electrostatic load does not have to be expected. Multiple coatings that are thicker than 200 µm are prohibited for explosion group IIC.

5.7 Breakdowns, causes and elimination

The below-mentioned failures can lead to a use of the **ROTEX®** coupling other than intended. In addition to the specifications given in these operating and assembly instructions please make sure to avoid these failures. The trouble listed can only be clues to search for the failures. When searching for the failure the adjacent components must generally be included.



If used other than intended the coupling can become a source of ignition. EC Standard 94/9/EC requires a special care from the manufacturer and the user.

General failures with use other than intended:

- Important data for the coupling selection were not forwarded.
- The calculation of the shaft/hub connection was not considered.
- Coupling components with damage occurred during transport are assembled.
- If the heated hubs are assembled, the permissible temperature is exceeded.
- The clearance of the parts to be assembled is not coordinated with each other.
- Tightening torques are fallen below/exceeded.
- Components are exchanged by mistake/assembled incorrectly.
- A wrong or no spider/ DZ elements are inserted in the coupling.
- No original **KTR** parts (purchased parts) are used.
- Old/already worn out spiders/ DZ elements or spiders/ DZ elements stored for too long are used.

Please note protection mark ISO 16016.	Drawn:	30.10.12 Pz/Bru	Replaced for:	KTR-N valid from 21.05.10
	Verified:	16.11.12 Pz	Replaced by:	



5 Enclosure A

Advice and instructions regarding the use in  hazardous areas

5.7 Breakdowns, causes and elimination

Continuation:

- The coupling used/the coupling protection used is not suitable for the operation in hazardous areas and does not correspond to EC directive 94/9/EC, respectively.
- Maintenance intervals are not observed.

Breakdowns	Causes	Hazard notes for hazardous areas	Elimination
different operating noise and/or vibrations occurring	misalignment	increased temperature on the spider surface; danger of ignition by hot surfaces	1) Set the unit out of operation 2) Eliminate the reason for the misalignment (e. g. loose foundation bolts, breaking of the engine mount, heat expansion of unit components, modification of the mounting dimension E of the coupling). 3) Inspection of wear see item inspection.
	wear of spider, short-term torque transmission due to metal contact	danger of ignition due to sparking	1) Set the unit out of operation 2) Disassemble the coupling and remove remainders of the spider 3) Inspect coupling components and replace coupling components that are damaged. 4) Insert spider, assemble coupling components. 5) Inspect alignment, adjust if necessary.
	loose screws for axial fastening of hubs	danger of ignition due to hot surfaces and sparking	1) Set the unit out of operation 2) Inspect alignment of coupling 3) Tighten the screws to secure the hubs and secure against loosening 4) Inspection of wear see item inspection
breaking of cam	wear of spider, torque transmission due to metal contact	danger of ignition due to sparking	1) Set the unit out of operation 2) Replace complete coupling 3) Inspect alignment
	breaking of the cams due to high impact energy/overload	danger of ignition due to sparking	1) Set the unit out of operation 2) Replace complete coupling 3) Inspect alignment 4) Find out the reason for overload
	operating parameters do not correspond to the performance of the coupling	danger of ignition due to sparking	1) Set the unit out of operation 2) Review the operating parameters and select a bigger coupling (consider installation space) 3) Assemble new coupling size 4) Inspect alignment
	operating error of the unit	danger of ignition due to sparking	1) Set the unit out of operation 2) Replace complete coupling 3) Inspect alignment 4) Instruct and train the service staff



5 Enclosure A

Advice and instructions regarding the use in  hazardous areas

5.7 Breakdowns, causes and elimination

Breakdowns	Causes	Hazard notes for hazardous areas	Elimination
early wear of spider	misalignment	increased temperature on the spider surface; danger of ignition by hot surfaces	1) Set the unit out of operation 2) Eliminate the reason for the misalignment (e. g. loose foundation bolts, breaking of the engine mount, heat expansion of unit components, modification of the mounting dimension E of the coupling) 3) Inspection of wear see item inspection
	e. g. contact with aggressive liquids/ oils, ozone-influence, too high/low ambient temperatures etc. causing a physical change of the spider	danger of ignition due to sparking in case of metallic contact of the cams	1) Set the unit out of operation 2) Disassemble the coupling and remove remainders of the spider 3) Inspect coupling components and replace coupling components that are damaged 4) Insert spider, assemble coupling components 5) Inspect alignment, adjust if necessary 6) Make sure that further physical modifications of the spider are excluded
	ambient/contact temperatures which are too high for the spider, max. permissible e. g. with T-PUR® T4 = - 50 °C/ + 120 °C	danger of ignition due to sparking in case of metallic contact of the cams	1) Set the unit out of operation 2) Disassemble the coupling and remove remainders of the spider 3) Inspect coupling components and replace coupling components that are damaged 4) Insert spider, assemble coupling parts 5) Inspect alignment, adjust if necessary 6) Inspect and adjust ambient/contact temperature (possibly remedy by using different spider materials)
early wear of spider (liquefaction of material inside the spider cam)	drive vibrations	danger of ignition due to sparking in case of metallic contact of the cams	1) Set the unit out of operation 2) Disassemble the coupling and remove remainders of the spider 3) Inspect coupling components and replace coupling components that are damaged 4) Insert spider, assemble coupling components 5) Inspect alignment, adjust if necessary 6) Find out the reason for the vibrations (possibly remedy by spider with lower or higher Shore hardness)



If you operate with a worn spider/ DZ elements (see item 5.2) and the subsequent contact of metal parts a proper operation meeting the explosion protection requirements and acc. to directive 94/9/EC is not ensured.



KTR Kupplungstechnik
GmbH
D-48407 Rheine

ROTEX®
Operating/Assembly instructions

KTR-N 40210 EN
Sheet: 21 of 21
Edition: 17

5 Enclosure A

Advice and instructions regarding the use in  hazardous areas

5.8 EC certificate of conformity

EC Certificate of Conformity

corresponding to EC directive 94/9/EC dated 23 March 1994
and to the legal regulations

The manufacturer - KTR Kupplungstechnik GmbH, D-48432 Rheine - states that the

flexible ROTEX® couplings

in an explosion-proof design described in these mounting instructions correspond to article 1 (3) b) of directive 94/9/EC and comply with the general safety and health requirements according to enclosure II of directive 94/9/EC.

The ROTEX® torsionally flexible coupling is in accordance with the specifications of the directive 94/9/EC. One or several directives mentioned in the corresponding EC type examination certificate IBExU02ATEXB001_05 X were in part replaced by updated versions.
KTR Kupplungstechnik GmbH being the manufacturer confirms that the product mentioned above is in accordance with the specifications of the new directives, too.

According to article 8 (1) of directive 94/9/EC the technical documentation is deposited with the institution:

IBExU
Institut für Sicherheitstechnik GmbH
Fuchsmühlenweg 7

09599 Freiberg

Rheine,
City

30.10.2012
Date

i. V. 
Reinhard Wibbeling
Engineering Manager

i. V. 
Michael Brüning
Product Manager

Please note protection
mark ISO 16016.

Drawn: 30.10.12 Pz/Bru
Verified: 16.11.12 Pz

Replaced for: KTR-N valid from 21.05.10
Replaced by: