



MOTORSERVICE
RHEINMETALL AUTOMOTIVE

KS PERMAGLIDE® plain bearings

Catalogue

Original

KS PERMAGLIDE®

plain bearings

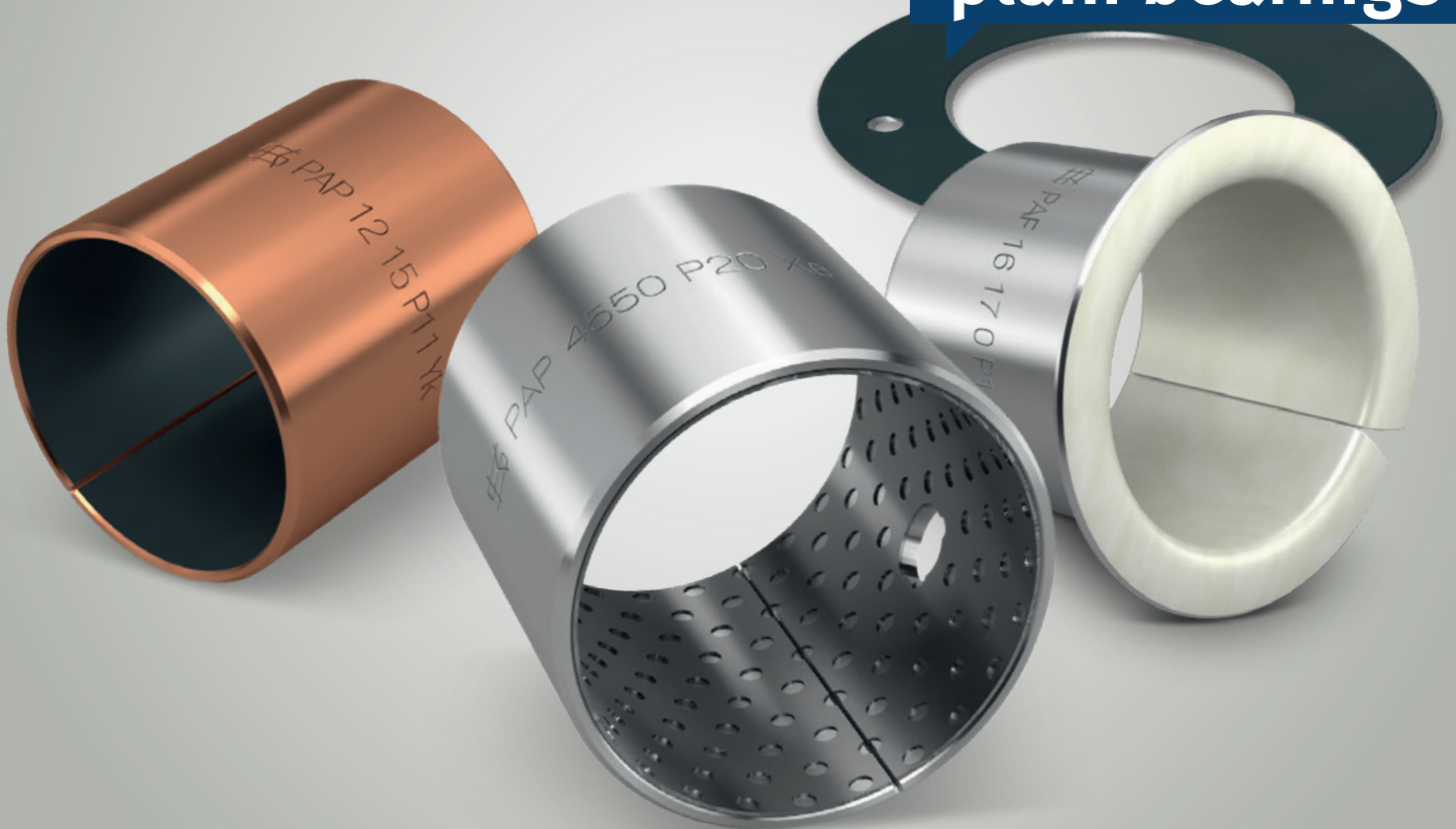

PERMAGLIDE®



Motorservice Group

Quality and service from a single source

The Motorservice Group is the sales organisation for the worldwide aftermarket activities of Rheinmetall Automotive. It is a leading supplier of engine components for the independent aftermarket. With the premium brands KOLBENSCHMIDT, PIERBURG, TRW Engine Components and the BF brand, Motorservice offers its customers a wide and comprehensive range of top quality products from a single source. Motorservice is also a sales partner for maintenance-free and low-maintenance KS PERMAGLIDE® plain bearings and other components for industry and technical trade.



KS Gleitlager

Within the Rheinmetall Automotive Group, KS Gleitlager is the specialist for high-precision bearings. The introduction of new technologies in production and surface finishing, innovative material developments and a clear customer focus have made KS Gleitlager one of the world's leading suppliers of engine plain bearings and dry plain bearings (KS PERMAGLIDE®).



Rheinmetall Automotive

Renowned supplier to the international automotive industry

Rheinmetall Automotive is the mobility division of the technology corporation Rheinmetall Group. With its premium brands KOLBENSCHMIDT, PIERBURG and Motorservice, Rheinmetall Automotive is a global leader in the relevant markets for air supply systems, emission control and pumps and in the development, manufacture and spare-parts supply of pistons, engine blocks and plain bearings. Low pollutant emissions, good fuel economy, reliability, quality and safety are the main driving forces behind the innovations of Rheinmetall Automotive.

PERMAGLIDE® is a registered trademark of KS Gleitlager GmbH

6th edition 02/2016 (032018)
Article no. 50 003 863-02

Editorial department:
Motorservice, Product Management

Layout and production:
Motorservice, Marketing
Die Neckarprinzen GmbH, Heilbronn

This document must not be reprinted, duplicated or translated in full or in part without our prior written consent and without reference to the source of the material.

All content including pictures and diagrams is subject to alteration. No liability accepted.

Published by:
© MS Motorservice Deutschland GmbH

Liability

All information in this brochure has been carefully researched and compiled. Nevertheless, it is possible that errors have occurred, information has been translated incorrectly, information is missing or the details provided have changed in the intervening time. As a result, we are unable to provide any guarantee nor to accept any legal liability for the accuracy, completeness, currency or quality of the information provided. We hereby waive all liability for any damages, whether direct or indirect in nature and whether tangible or intangible, resulting from the use or misuse of information or from incomplete or incorrect information in this brochure, unless proven to be the result of deliberate intent or negligence on our part. The parts outlined in the catalogue are not designed for use in aircraft. Names, descriptions and numbers of products, manufacturers, etc. are included for the purpose of comparison only.

Contents	Page
1 Material overview	4
2 Designations and units	8
3 KS PERMAGLIDE® plain bearings	9
3.1 Introduction material P1	10
3.2 Introduction material P2	15
4 Material selection, material information	19
4.1 P1 plain bearings	20
4.2 P2 plain bearings	27
5 Nominal service life calculation	31
6 Typical plain bearing damage	39
7 Design and layout of bearing position	42
8 Plain bearing mounting	51
9 Models and tables of dimensions	55
9.1 KS PERMAGLIDE® bushes, maintenance-free	57
9.2 KS PERMAGLIDE® flange liners, maintenance-free	63
9.3 KS PERMAGLIDE® thrust washers, maintenance-free	65
9.4 KS PERMAGLIDE® strips, maintenance-free	66
9.5 KS PERMAGLIDE® bushes, low-maintenance	67
9.6 KS PERMAGLIDE® thrust washers, low-maintenance	69
9.7 KS PERMAGLIDE® strips, low-maintenance	70
9.8 KS PERMAGLIDE® special production	71
10 Test methods	72

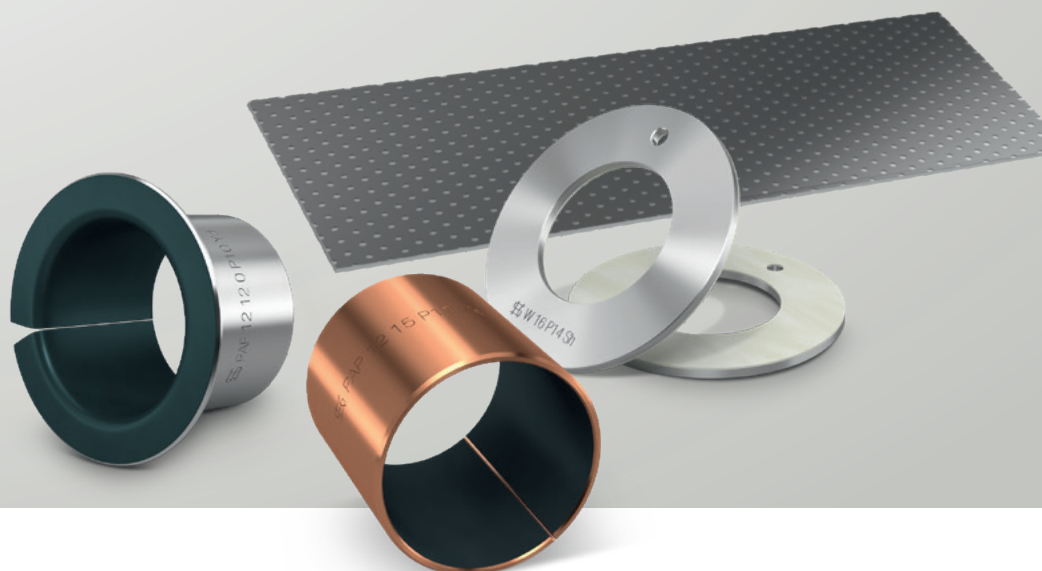

1 | Material overview

KS PERMAGLIDE® P1 plain bearings

- Maintenance-free
- Suitable for dry running

Characteristics	Unit	P10, P11	P14	P147*
Unleaded	–	No	Yes	Yes
$p v_{max}$	MPa · m/s	1.8	1.6	1.4
$p_{max.stat.}$	MPa	250	250	250
$p_{max.dyn.}$	MPa	56 at $v \leq 0.032$ m/s	56 at $v \leq 0.029$ m/s	56 at $v = 0.025$ m/s
$v_{max.}$	m/s	2 at $p \leq 0.90$ MPa	1 at $p \leq 1.60$ MPa	0.8 at $p \leq 1.75$ MPa
T	°C	-200 to +280	-200 to +280	-200 to +280

Materials KS PERMAGLIDE® P1



Standard material P10

- Contains lead
- Very low stick-slip tendency
- Low wear
- Good chemical resistance
- Low friction value
- No tendency to fuse with metal
- Largely resistant to swelling
- Does not absorb water

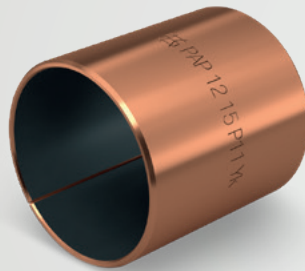

Standard material P11

- Contains lead
- Improved corrosion resistance
- Very good thermal conductivity and therefore greater operational safety
- Anti-magnetic
- All other properties as P10



Standard material P14

- Unleaded
- Compliant with Directive 2002/95/EC (RoHS)
- Very low stick-slip tendency
- Low wear
- Low friction value
- No tendency to fuse with metal
- Largely resistant to swelling

Special material P147*

- Unleaded
- Compliant with Directive 2002/95/EC (RoHS)
- Very good corrosion resistance
- All other properties similar to P14

* On request

Models KS PERMAGLIDE® P1

PAP bushes



PAP P10

PAF flange bushes

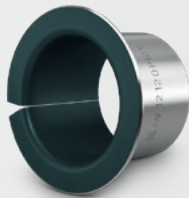

PAF P10

PAW thrust washers



PAW P10

PAS strips

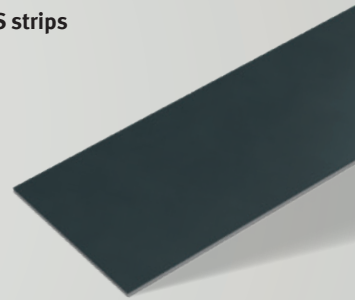

PAS P10

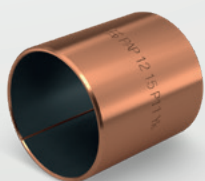

PAP P11

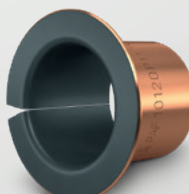

PAF P11



PAW P11

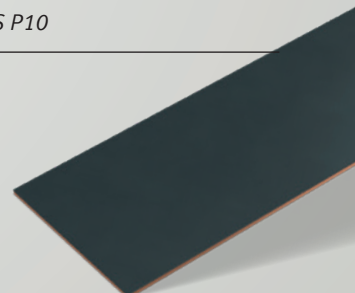

PAS P11



PAP P14, PAP P147*

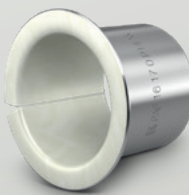

PAF P14, PAF P147*

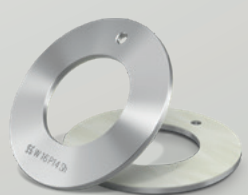

PAW P14, PAW P147*



PAS P14, PAS P147*

KS PERMAGLIDE® P2 plain bearings

- Low-maintenance
- For grease or liquid-lubricated applications

Characteristics	Unit	P20, P22*, P23*	P200, P202*, P203*
Unleaded	–	No	Yes
$p v_{max}$	MPa · m/s	3	3.3
$p_{max.stat.}$	MPa	250	250
$p_{max.dyn.}$	MPa	70 at $v \leq 0.042$ m/s	70 at $v \leq 0.047$ m/s
$v_{max.}$	m/s	3 at $p \leq 1.00$ MPa	3.3 at $p \leq 1.00$ MPa
T	°C	-40 to +110	-40 to +110

Materials KS PERMAGLIDE® P2



Standard material P20

- Contains lead
- With oil distributing pockets, ready to install
- Lifetime lubrication possible
- Low wear
- Low sensitivity to edge loading
- Good damping characteristics
- Insensitive to impact loads
- Good chemical resistance

Special material P22*

- Contains lead
- Smooth sliding surface, with machining allowance
- All other properties as P20

Special material P23*

- Contains lead
- Smooth sliding surface, ready to install
- All other properties as P20

Standard material P200

- Unleaded
- Compliant with Directive 2002/95/EC (RoHS)
- With oil distributing pockets, ready to install
- Lifetime lubrication
- Low wear
- Very good dry-running properties
- Insensitive to edge loading and impacts
- Good damping characteristics
- Good chemical resistance

Special material P202*

- Unleaded
- Compliant with Directive 2002/95/EC (RoHS)
- Smooth sliding surface, with machining allowance
- All other properties similar to P20

Special material P203*

- Unleaded
- Compliant with Directive 2002/95/EC (RoHS)
- Smooth sliding surface, ready to install
- All other properties similar to P20

* On request

Models KS PERMAGLIDE® P2

PAP bushes



PAP P20, PAP P22, PAP P23*, PAP P200,
PAP P202*, PAP P203**

PAW thrust washers



PAW P20, PAW P22, PAW P23*, PAW P200,
PAW P202*, PAW P203**

PAS strips

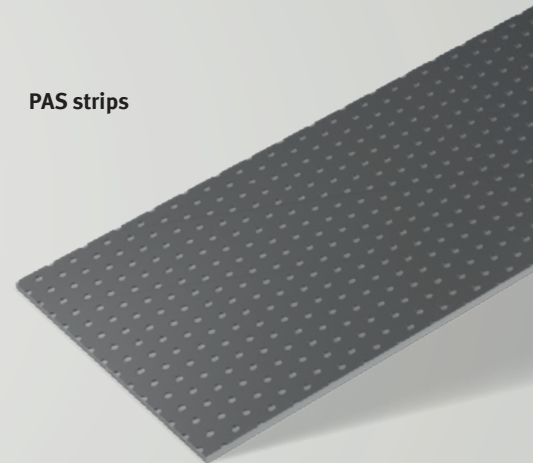

PAS P20, PAS P22, PAS P23*, PAS P200,
PAS P202*, PAS P203**

2 | Descriptions and units

Unless otherwise expressly noted in the text, the descriptions, units and meaning of the values used in this catalogue are as follows.

Designation	Unit	Designation
B	mm	Liner length, total strip width
B_1	mm	Usable strip width
C_i	mm	Inside bevel of bush (bevelled edge)
C_o	mm	Outside bevel of bush
D_{FL}	mm	Flange diameter
D_i	mm	Inside diameter of bush Inside diameter of thrust washer
D_{iE}	mm	Bush inside diameter in pressed-in state
D_o	mm	Outside diameter of bush Outside diameter of thrust washer
d_{ch}	mm	Diameter of test holder (adjusting mandrel)
d_G	mm	Diameter of housing bore
d_H	mm	Inside diameter of auxiliary ring
d_K	mm	Diameter of calibrating mandrel
d_L	mm	Oil hole diameter
d_W	mm	Shaft diameter
d_1	mm	Diameter of mounting hole in thrust washer
d_{6a}	mm	Diameter of housing recess for thrust washer
F	N	Bearing stress, press-in force
F_{ch}	N	Test force
F_E	N	Press-in force per mm of liner length
F_{tot}	N	Total press-in force
f_G	mm	Chamfer width on housing
f_A	–	Load type correction factor
f_L	–	Linear movement correction factor
f_p	–	Load correction factor
f_R	–	Roughness depth correction factor
f_T	–	Temperature correction factor
f_v	–	Sliding speed correction factor
f_W	–	Material correction factor

Designation	Unit	Designation
H	mm	Stroke on linear movement
Y	mm	Pitch circle diameter of thrust washer
L	mm	Strip length
L_N	h	Nominal service life
m	g	Earth
n	rpm	Engine speed
n_{OSZ}	rpm	Oscillating frequency of oscillating movement
p	MPa	Specific bearing stress
pv	MPa · m/s	pv value, product from specific bearing stress and sliding speed
R, r	mm	Radius
R_z, R_a	μm	Roughness depth
s_1	mm	Thickness of steel or bronze back
s_3	mm	Wall thickness of bush
s_{FL}	mm	Flange thickness
T	°C	Temperature
t_a	mm	Depth of housing recess
v	m/s	Sliding speed
x	mm	Measuring line distance
z	mm	Distance between test holder halves
α_{Bz}	K^{-1}	Thermal expansion coefficient of bronze
α_{St}	K^{-1}	Thermal expansion coefficient of steel
Δs	mm	Theoretical bearing clearance
Δz	mm	Measured value in test holder
λ_{Bz}	$\text{W}(\text{mK})^{-1}$	Coeff. of thermal conductivity, bronze
λ_{St}	$\text{W}(\text{mK})^{-1}$	Coeff. of thermal conductivity, steel
μ	–	Coefficient of friction
τ_s	N/mm^2	Shear strength
ϕ	°	Swivel angle

Plain bearings are used to absorb and convey forces between components that move relative to one another. They determine the position of the moved components in relation to one another and ensure accuracy of the movement.

Plain bearings must satisfy many requirements. They must be capable of tolerating high mechanical loads to the greatest possible extent, while suffering only minimal wear throughout their service life. They must also withstand high sliding

speeds and be insensitive to disturbances from the bearing environment. Fig. 1 shows just how complex a tribological system can be, at the centre of which a plain bearing is working.

Influences in a tribological system

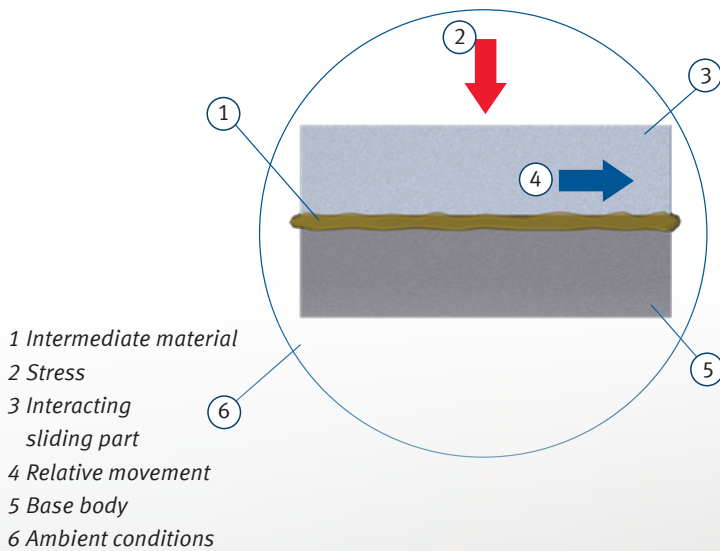

Ambient conditions

- Temperature, medium, dirt

Stress

- Amount and load type (static, dynamic)
- Load time (constant, with intervals), circumferential load, concentrated load

Interacting sliding part

- Material, hardness, surface roughness, thermal conductivity

Relative movement

- Rotating, oscillating, linear
- Sliding speed, duration of movement

Intermediate material

- Solid lubricant, grease, liquid, viscosity,
- Ageing resistance

Base body

- Material, hardness, surface roughness, wear resistance, limp-home capability,
- Chemical resistance

Fig. 1: Tribological system

In terms of the operating mode, we distinguish between three different functional systems:

- Dry-running, maintenance-free plain bearings
- Grease-lubricated, low-maintenance plain bearings
- Hydrodynamically operated plain bearings

Plain bearings that work on the principles of hydrodynamics can satisfy the various requirements comparatively well. In this way, oil-lubricated plain bearings in particular can be designed for optimum, reliable operation with the aid of modern calculation methods. Low-maintenance plain bearings are generally lubricated with grease. The

quantity of grease applied during installation is normally sufficient for the entire service life. If a grease-lubricated plain bearing is used in difficult conditions, subsequent lubrication is recommended. Correctly timed relubricating intervals can considerably lengthen the service life.

Due to the many influencing factors, however, calculating the expected service life of grease-lubricated plain bearings is fraught with uncertainty and can only be used as a guide.

But in many cases, lubrication using oil or grease is not possible or not permitted. In cases like this, maintenance-free, dry-running plain bearings are employed.

Here, too, calculating the service life is not sufficiently precise.

The common practice of calculating service life using simple methods and taking into account influencing factors (such as specific load, sliding speed, temperature, etc.) can provide only approximate standard values. It is therefore recommended to verify the design and layout of both maintenance-free, dry-running plain bearings and low-maintenance ones through field-oriented tests.

The sections that follow discuss the special functional models of maintenance-free and low-maintenance plain bearings.

3 | KS PERMAGLIDE® plain bearings

3.1 Introduction material P1

3.1.1 General

The P1 material group includes the materials P10, P11, P14 and P147. P10 and P11 contain lead in the bronze sliding layer and the lubricant mass. P14 and P147 are unleaded.

3.1.2 Material composition

Materials in the P1 group consist of a steel or bronze back, a sintered sliding layer of special bronze with a layer thickness of 0.2 mm to 0.35 mm and a solid lubricant mass. The bronze sliding layer is sintered in such a way as to achieve a porosity volume of approx. 30%. A solid lubricant mixture – usually PTFE with bulking agents – is rolled in and sintered through the gaps in the porous sliding layer. The solid lubricant mixture completely fills the cavities and forms a running-in layer up to 0.03 mm thick above the bronze sliding layer (Fig. 2).

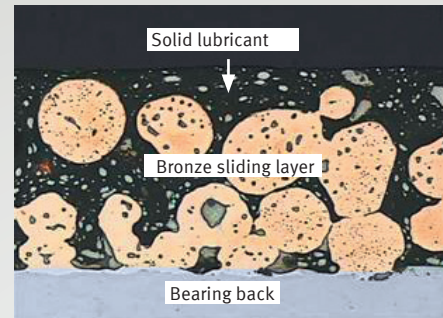
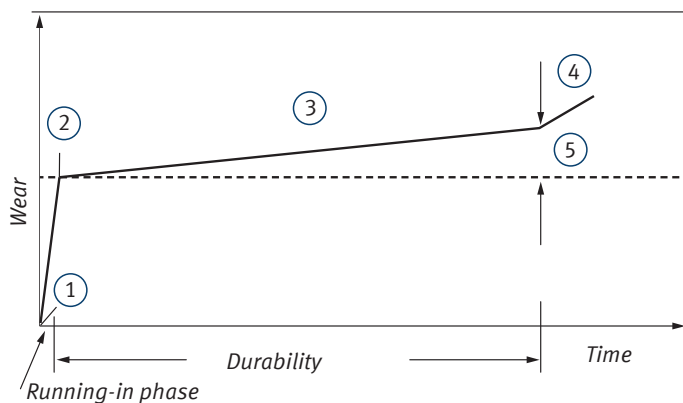

Fig. 2: P1 layer system

3.1.3 Function description

Maintenance-free, dry-running P1 plain bearings go through four phases during their overall service life (Fig. 3).



- | | | |
|---------------------|-----------------------|----------------------------|
| 1 Initial condition | 3 During service life | 5 Maximum permissible wear |
| 2 End of run-in | 4 End of service life | |

Fig. 3: Wear curve of P1 plain bearing (schematic) /1/

Initial state

The cavities in the bronze sliding layer are completely filled with solid lubricant, and the running-in layer above the bronze sliding layer is still in perfect condition (Fig. 4).

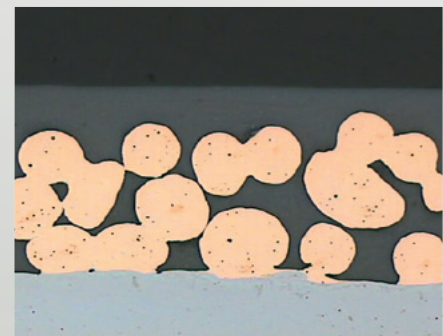

Fig. 4: Condition of sliding surface in the initial state

Run-in

As the sliding movement commences, parts of the running-in layer are transferred to the moving interacting sliding partner (Fig. 6). During this process, a sealed film of solid lubricant forms on the interacting sliding partner, which considerably reduces the friction. This run-in causes material to be removed from the sliding layer of the bearing amounting to between 0.005 mm and 0.030 mm. The condition of the sliding surface at the end of the running-in period can be seen in Fig. 5.

Continuous operation

Once the run-in is complete, the plain bearing commences its actual useful life. This is determined by the load collective and ambient conditions, but also by the

ratio of the bronze sliding layer volume to the solid lubricant volume. During the period of operation, new solid lubricant is constantly entering the contact zone, replacing the used bits of solid lubricant. This process is triggered, above all, by the different coefficients of thermal expansion of the bronze sliding layer and the solid lubricant (ratio approx. 1 : 5.5). When the sliding layer heats up due to the friction work in the contact zone, the solid lubricant expands to a greater extent, lubricating the interacting sliding partner. This lowers the friction value and the bearing temperature. When the lubricant is used up, a new cycle commences. A typical curve is shown in Fig. 7. The condition of the sliding surface at the end of the service life can be seen in Fig. 8.



Fig. 5: Condition of sliding surface at end of the run-in

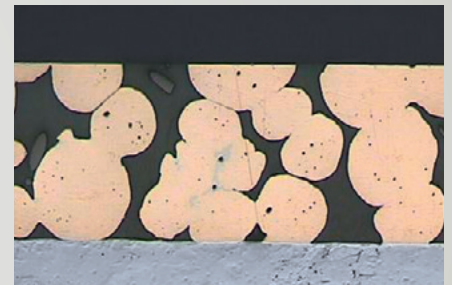

Fig. 8: Condition of the sliding surface during service life

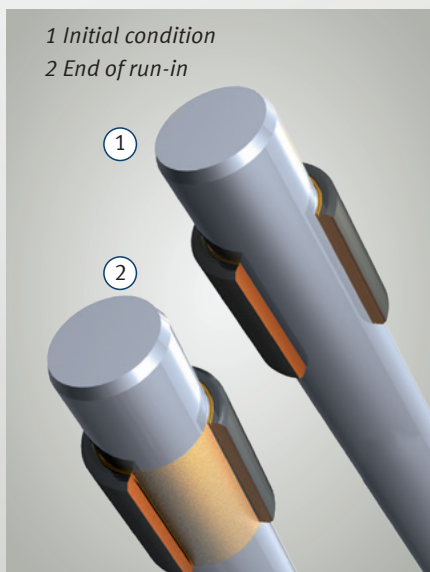

Fig. 6: Material transfer

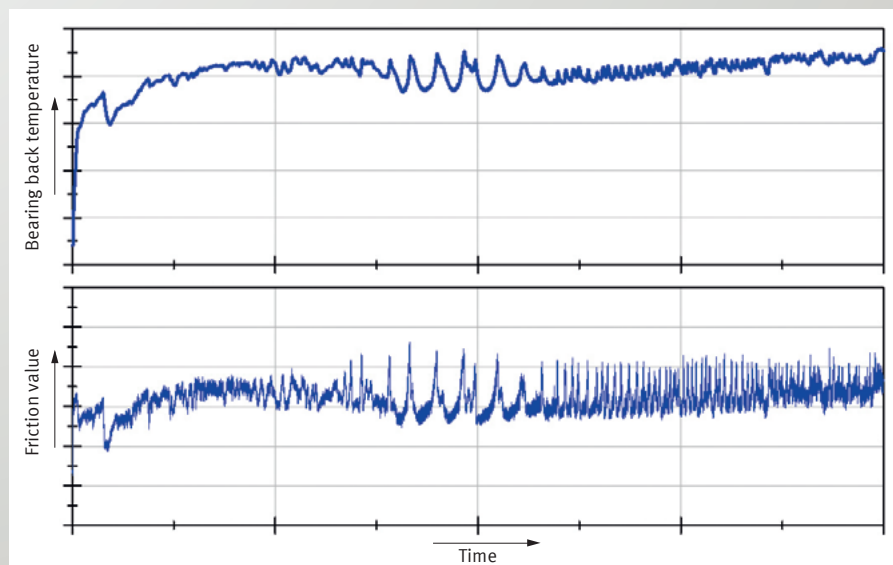

Fig. 7: Oscillation characteristic of friction value and temperature

3 | KS PERMAGLIDE® plain bearings

End of service life

The solid lubricant in the plain bearing system is only available to a limited extent (determined by the pore volume of the porous, sintered bronze sliding layer). If the lubricant volume is used up due to a longer period of use, the friction value rises and wear intensity increases. In most cases, this

also causes the permitted wear limit to be exceeded. In P1 plain bearings, this is normally > 0.05 mm. At high sliding speeds, in particular, this may also result in overheating of the bearing and shaft seizure. The condition of the sliding surface at the end of the service life can be seen in Fig. 9.



Fig. 9: Condition of sliding surface at end of service life

3.1.4 Limit values and influencing factors

Service life and operational safety are determined by many different influences, which also interact with one another. The most important influencing factors and limit values are explained below.

Maximum permitted pv value

The pv value is the product of specific bearing stress p [MPa] and sliding speed v [m/s].

These two variables interact with one another. Fig. 10 shows the maximum permitted pv value for P1 plain bearings in the form of a limit curve. If the specific bearing stress and sliding speed lie within this limit curve, it is basically safe to assume that the P1 plain bearing is suitable for use.

Standard function limits:

P10, P11	
0.03 m/s	$< v \leq 2$ m/s
0.1 MPa	$< p \leq 56$ MPa
P14	
0.03 m/s	$< v \leq 1$ m/s
0.1 MPa	$< p \leq 56$ MPa
P147	
0.03 m/s	$< v \leq 0.8$ m/s
0.1 MPa	$< p \leq 56$ MPa

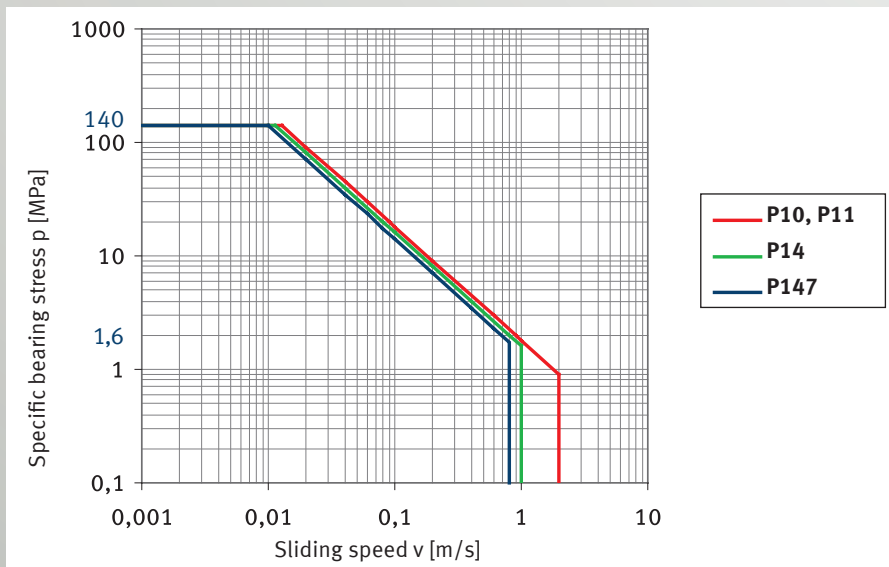

Fig. 10: pv value [MPa · m/s], limit curve (values apply at room temperature)

Here, the limit curve indicates that at the respective specific bearing stress p_{max} [MPa] and associated sliding speed v [m/s], thermal equilibrium is reached during operation, i.e. the plain bearing system still works reliably and safely. If the load or sliding speed increases beyond the limit curve, there is no thermal equilibrium. The wear intensity and temperature increase, and the plain bearing may fail within a short time.

Specific bearing stress

At the maximum permitted specific bearing stress and the respective maximum permitted sliding speed, the following threshold values apply to a maintenance-free, dry-running P1 plain bearing:

Maximum specific bearing stress p [MPa]		Sliding speed v [m/s]		
		P10, P11	P14	P147
Static	250 MPa	–	–	
Concentrated load at rest, uniform movement	140 MPa	≤ 0.013 m/s	≤ 0.011 m/s	≤ 0.010 m/s
Concentrated load at rest, rotating, oscillating	56 MPa	≤ 0.032 m/s	≤ 0.029 m/s	≤ 0.025 m/s
Concentrated load, circumferential load, increasing, rotating, oscillating	28 MPa	≤ 0.064 m/s	≤ 0.057 m/s	≤ 0.050 m/s

Tab. 1: Threshold values of specific bearing stress

Sliding speed

For maintenance-free, leaded P1 plain bearings, the sliding speed v during dry running is limited to max. 2 m/s. For unleaded P1 plain bearings, the maximum sliding speed v_{max} is 1 m/s for P14 and 0.8 m/s for P147. In a plain bearing assembly, the sliding speed is understood as the relative speed in m/s between the

bearing and the shaft. It is of paramount importance in a tribological system, and in combination with the specific bearing stress is a determining factor for the area of application of a plain bearing assembly. See also Fig. 10: pv value limit curve. A high sliding speed exerts a particular influence on bearing wear. The long sliding distance during the operating period gives rise to

correspondingly high wear. However, the bearing temperature is also dependent upon the sliding speed. If the tribological system no longer enjoys a state of thermal equilibrium as the result of an excessive sliding speed, the permitted stress limit is exceeded.

Friction, bearing stress, sliding speed

These three variables interact with one another. This relationship tends to manifest as follows:

Specific bearing stress p [MPa]		Sliding speed v [m/s]		Coefficient of friction μ [1]	
140 up to 250	↑ high low	up to 0.001		0.03	low
140 up to 60		0.001 up to 0.005		0.04 up to 0.07	↓ high
60 up to 10		0.005 up to 0.05		0.07 up to 0.1	
10 up to 1		0.050 up to 0.5		0.10 up to 0.15	
up to 1		0.500 up to 2		0.15 up to 0.25	high

Tab. 2: Friction coefficient

(all values apply at 20 °C, interacting sliding surface steel, roughness depth Rz 0.8 to Rz 1.5)

Friction and interacting sliding parts (material and surface)

The operational safety and service life of a maintenance-free bearing position depend not only on the load collective, but also on the material and surface of the interacting sliding part. The materials of the interacting sliding parts may exert a considerable influence on the wear properties and thus the service life of a maintenance-free, dry-running P1 plain bearing. It is basically advantageous in terms of service life to employ interacting sliding parts with a hardened sliding surface, or one featuring

a special coating. This is particularly the case under higher stresses or at higher sliding speeds. The surface roughness of the interacting sliding part is also extremely important in respect of the reliability and service life of the tribological pairing. The most favourable friction conditions are achieved with a surface roughness of R_z 0.8 to R_z 1.5. If the surface is excessively smooth, insufficient solid lubricant is deposited on the interacting sliding part. Adhesion repeatedly occurs during the sliding movement, resulting in stick-slip

effects, squeaking noises and problems during operation. If the surface of the interacting sliding part is too rough, on the other hand, the available solid lubricant in the plain bearing is no longer adequate for producing a sealed film of lubricant on the interacting sliding part. The consequence is abrasion, together with increased friction, a rise in temperature and increased wear.

3 | KS PERMAGLIDE® plain bearings

Friction and temperature (ambient temperature)

The operating temperature range within which a maintenance-free plain bearing system works is important for operational safety and service life. This is particularly the case because the mechanical properties of the solid lubricant so vital to the performance of a plain bearing change with variations in temperature. Thus, the friction value is slightly lower at an operating temperature of approx. 100 °C than at room temperature. If the operating temperature rises much over 100 °C, this effect is reversed. The friction value rises and can be up to 50% greater than the value at room temperature. This causes a change in the bearing temperature, and consequently the mechanical properties of the solid lubricant. The element of solid lubricant important for friction is the polymer PTFE. The shear strength of PTFE, above all, is responsible for forming and maintaining the lubricating film on the interacting sliding part. However, the shear strength of PTFE is temperature-dependent (Fig. 11).

If the operating temperature rises, the shear strength diminishes proportionately. /2/ If the shear stress occurring in the contact zone due to the friction process is greater than the shear strength of PTFE, the lubricating film in the contact zone shears off, which can lead to rapid failure.

Sliding movement and load type

The load type – concentrated or circumferential – is also a factor in combination with rotating or swivelling motion. Concentrated load is the result of a moving shaft and stationary housing and bearing bush. With circumferential load, the housing and bearing bush move around the stationary shaft or axle. Rotating or swivelling movements under uniform stress principally produce wear, whereby the wear rate for bearing positions with circumferential load can be much lower than for bearing positions subject to concentrated load. If the bearing position is subject to high-frequency load changes or vibrations, this effect can be intensified by material fatigue. Where movements are linear, the bearing

generally slides against a longer area of the interacting sliding part. This causes more friction heat to be dissipated via the interacting sliding part. Therefore, higher sliding speeds are possible here than with rotating or swivelling movements.

Hydrodynamic operation

P1 plain bearings may also run under hydrodynamic conditions. Motorservice offers the relevant calculations as a service.

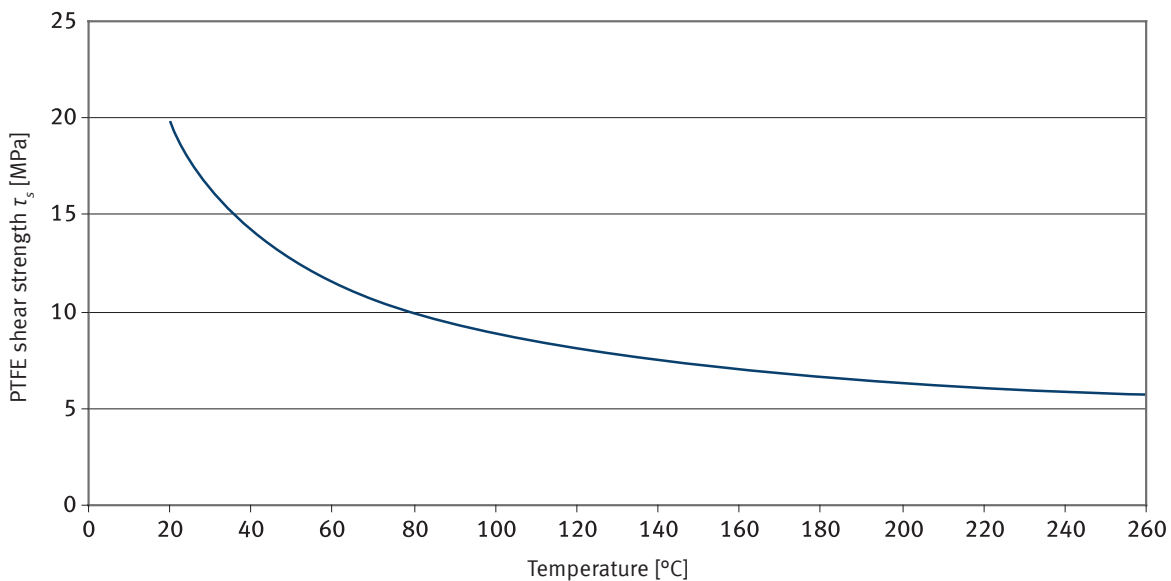

Fig. 11: PTFE shear strength τ_s versus temperature

3.2 Introduction material P2

3.2.1 Material composition

The material in P2 plain bearings consists of a steel back, a 0.2 mm to 0.35 mm thick bronze compound layer and a thermoplastic resin with bulking agents as a sliding layer. The resin sliding layer is embedded in the cavities (pore volume~50%) of the bronze compound layer, and forms a sliding surface

0.08 mm to 0.2 mm thick above the compound layer, depending on the intended purpose.

Two different sliding layer compositions exist within the P2 material group:

- P20, P22, P23 with lead
- P200, P202, P203 unleaded

The thickness and contours of the sliding layer may also vary. Details on this subject can be found in the material data sheets of this catalogue.

3.2.2 Function description

Low-maintenance P2 plain bearings are generally used in applications with lifetime lubrication. For this purpose, the oil distributing pockets in the sliding surface are completely filled with lubricant (grease) during assembly.

Run-in

At the beginning of the sliding movement, the grease in the sliding surface is transferred onto the interacting sliding partner (shaft). The two sliding surfaces are therefore separated by a thin layer of

lubricant. The friction value decreases during the sliding movement, assuming values of between 0.02 and 0.15.

The sliding surfaces of the bearing and interacting sliding part simultaneously adapt accordingly, i.e. unevenness in the material is worked off. This rubbed off material is largely deposited in the oil distributing pockets, and is initially no longer relevant to wear.

Continuous operation

Due to the design of the oil distributing

pockets (in conformity with DIN ISO 3547), sufficient lubricant is available for the expected period of operation. The friction value and temperature remain virtually constant for a longer period. The wear rate is minimal. This applies to low to medium strain.

At higher stress or in difficult operating conditions, however, regular relubrication of the bearing position is recommended. Correctly timed relubricating intervals reduce the wear rate and increase operational safety and service life accordingly.

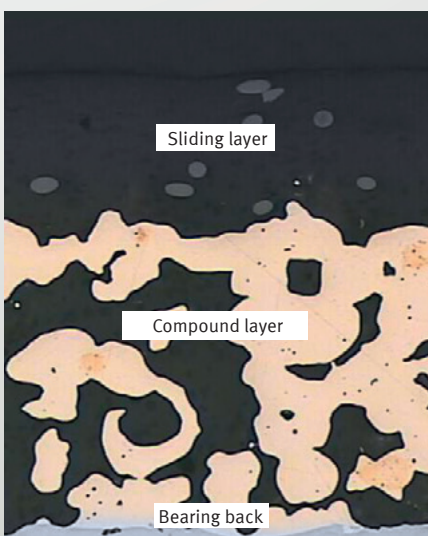

Fig. 12: P2 layer system

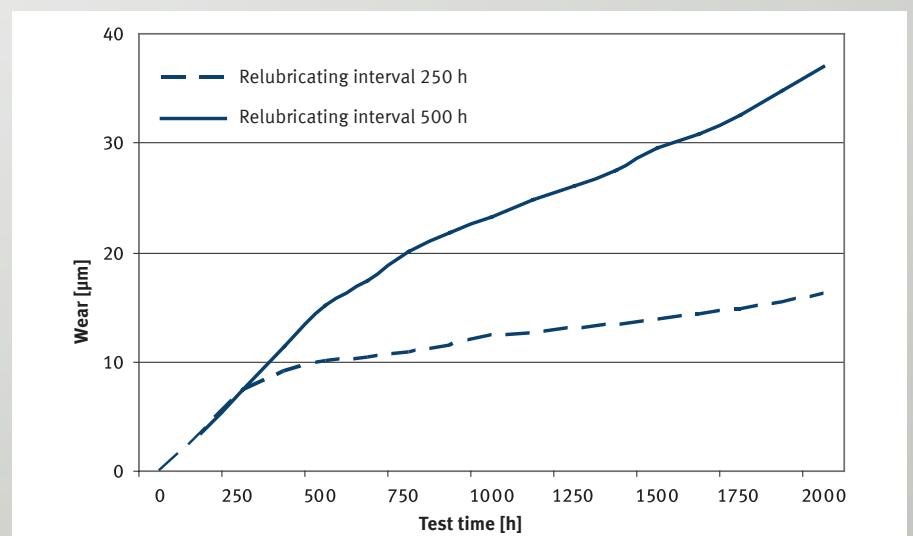

Fig. 13: Wear curve of P2 plain bearing (schematic)

3 | KS PERMAGLIDE® plain bearings

End of service life

After a longer period of operation and corresponding depth of wear, the lubricant volume of plain bearing applications with lifetime lubrication is used up. The type of lubricating grease and ambient conditions may also adversely affect the performance of the lubricant (ageing). Consequently, the friction value, bearing temperature and wear all rise disproportionately.

The bearing overheats and fails. Similar behaviour can also be expected in bearing assemblies requiring relubrication. Relubrication may considerably extend the service life of the bearing position, but even here, the depth of wear drastically reduces the capacity of the oil distributing pockets. Sufficient lubricant can no longer be deposited.

The effect is worsened by rubbed off material, which enters the oil distributing pockets and further limits their volume. Failure symptoms similar to those of lifetime lubricated plain bearings then occur.

3.2.3 Limit values and influencing factors

The service life and reliability of a low-maintenance plain bearing assembly are influenced not only by operating and ambient conditions, but also the lubricating conditions (grease, oil). As a rule, several influencing factors occur simultaneously and are also interdependent. The most important influencing factors and limit values are explained below.

Maximum permitted pv value

The pv value is the product of the specific bearing stress p [MPa] and the sliding speed v [m/s]. These two variables interact with one another. Fig. 14 shows the maximum permitted pv value for grease-lubricated P2 plain bearings in the form of a limit curve. If the specific bearing stress and sliding speed lie within this limit curve, it is basically safe to assume that the P2 plain bearing is suitable for use.

Range of application of service life calculation:

P20	
0.04 m/s	$\langle v \leq 3 \text{ m/s}$
0.1 MPa	$\langle p \leq 70 \text{ MPa}$
P200	
0.04 m/s	$\langle v \leq 3.3 \text{ m/s}$
0.1 MPa	$\langle p \leq 70 \text{ MPa}$

The limit curve indicates that at the respective specific bearing stress p [MPa] and associated sliding speed v [m/s],

thermal equilibrium is reached during operation, i.e. the plain bearing system still works reliably and safely. If the stress or sliding speed increases beyond the limit curve, no thermal equilibrium can be reached. The wear intensity and temperature increase and the bearing may fail within a short time. P2 plain bearings must be lubricated. Depending on the lubricant, service life may be lengthened. The limit curve shown here applies to lithium-soap grease, mineral oil-based grease and a temperature of 20 °C.

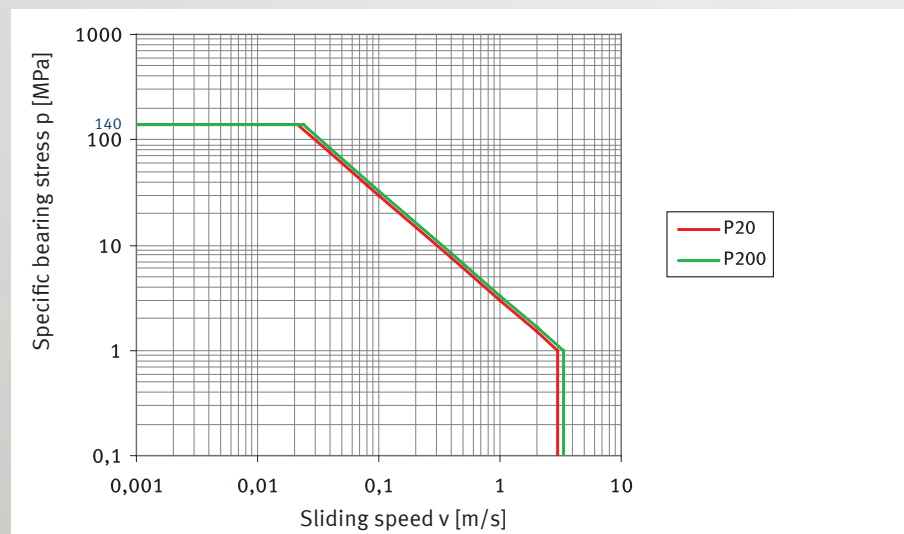

Fig. 14: pv values, limit curves for P20, P200 *, grease-lubricated at 20 °C

Specific bearing stress

At the maximum permitted specific bearing stress and the respective maximum permitted sliding speed, the following threshold values apply to a low-maintenance P2 plain bearing:

Maximum specific bearing stress p[MPa]		Sliding speed v [m/s]	
		P20, P22*, P23*	P200, P202*, P203*
Static	250 MPa	–	–
Concentrated load at rest, uniform movement	140 MPa	≤ 0.021 m/s	≤ 0.024 m/s
Concentrated load at rest, rotating, oscillating	70 MPa	≤ 0.043 m/s	≤ 0.047 m/s
Concentrated load, circumferential load, increasing, rotating, oscillating	35 MPa	≤ 0.086 m/s	≤ 0.094 m/s
Load limit (Fig. 14)	1.0 MPa	max. 3.0 m/s	max. 3.3 m/s

Tab. 3: Threshold values of spec. bearing stress

Sliding speed

For low-maintenance, plumbiferous P2 plain bearings, the maximum permitted sliding speed v with grease lubrication is limited to 3.0 m/s. For the low-maintenance unleaded P2 plain bearings, the maximum permissible sliding speed is 3.3 m/s. In this case, the sliding speed refers to a relative speed between a bearing and interacting sliding part. It is of paramount importance in a tribological system, and in combination with the specific bearing stress p is a determining factor for the area of application of a plain bearing. A high sliding speed exerts a particular influence on bearing wear. The long sliding distance during the operating period gives rise to correspondingly high wear. If the sliding speed rises above the permitted value, the plain bearing system is no longer in a state of thermal equilibrium. Operational problems and even failure can arise.

Grease lubrication

The service life of a P2 plain bearing is also influenced by the type of grease used. The friction value, load carrying capacity and permitted operating temperature, in particular, are dependent upon the lubricating grease. Ageing resistance is also an important factor for problem-free function.

Types of grease that are basically suitable are:

- Lithium-soap grease (ageing-resistant)
- Barium-soap grease (good adhesion)
- Aluminium-soap grease (good wettability)

Correctly timed relubricating intervals extend service life and improve operational safety (Fig. 13).

Friction and interacting sliding parts (material and surface)

The operational reliability and service life of a low-maintenance bearing position depend not only on the load collective and lubricant, but also on the material and surface of the interacting sliding part. The materials of the interacting sliding part may exert a considerable influence on service life (see Tab. 24). The surface roughness of the interacting sliding part is also extremely important in respect of the reliability and service life of the tribological pairing. The best conditions are provided by roughness depths of R_z 0.8 to R_z 1.5. With larger roughness depths, abrasion occurs with increased wear despite the use of grease as a lubricant.

* On request

Temperature

P2 plain bearings are extremely insensitive to operating temperatures up to approx. 70 °C. If temperatures rise considerably above this level, however, the bearing's performance drops abruptly. The practical operating limit is reached at a temperature of 110 °C. An operating temperature of 140 °C is possible for brief periods, but only if bearing stress is very low. The thermal resistance of the lubricant used (e.g. type of grease) must also be taken into consideration.

Sliding movement and stress

The load type – concentrated or circumferential – is also a factor in combination with rotating or swivelling motion. Concentrated load is the result of a moving shaft and stationary housing and bearing bush. With circumferential load, the housing and bearing bush move around the stationary shaft.

Rotating or swivelling movements under uniform stress principally produce wear. If the bearing position is subject to high-frequency load changes or vibrations, this effect can be intensified by material fatigue. Where movements are linear, the bearing generally slides against a longer area of the interacting sliding part. This causes more friction heat to be dissipated via the interacting sliding part. Therefore, higher sliding speeds are possible here than with rotating or swivelling movements.

Hydrodynamic operation

P2 plain bearings may also run under hydrodynamic conditions. To this aim, a sliding layer without oil distributing pockets is required.

Plain bearings without oil distributing pockets can be supplied ready to install or, on request, the inside diameter of bearings can be machined accordingly.

As calculation of hydrodynamic plain bearings is a complex task, Motorservice offers this service.

Material selection plan. Applies to dry-running and grease-lubricated plain bearings. For hydrodynamic operation, Motorservice offers calculation and material selection as a service.

Input variables		
The adjacent input variables are normally set out in the specification or are calculated (shaft). As an initial approximation, the bearing width must be provisionally determined as a function of the shaft in this plan.	<ul style="list-style-type: none"> • Bearing stress [MPa] • Shaft diameter [mm] • Engine speed [rpm] • Swivel angle [°] • Oscillating frequency [rpm] • Bearing width [mm] 	

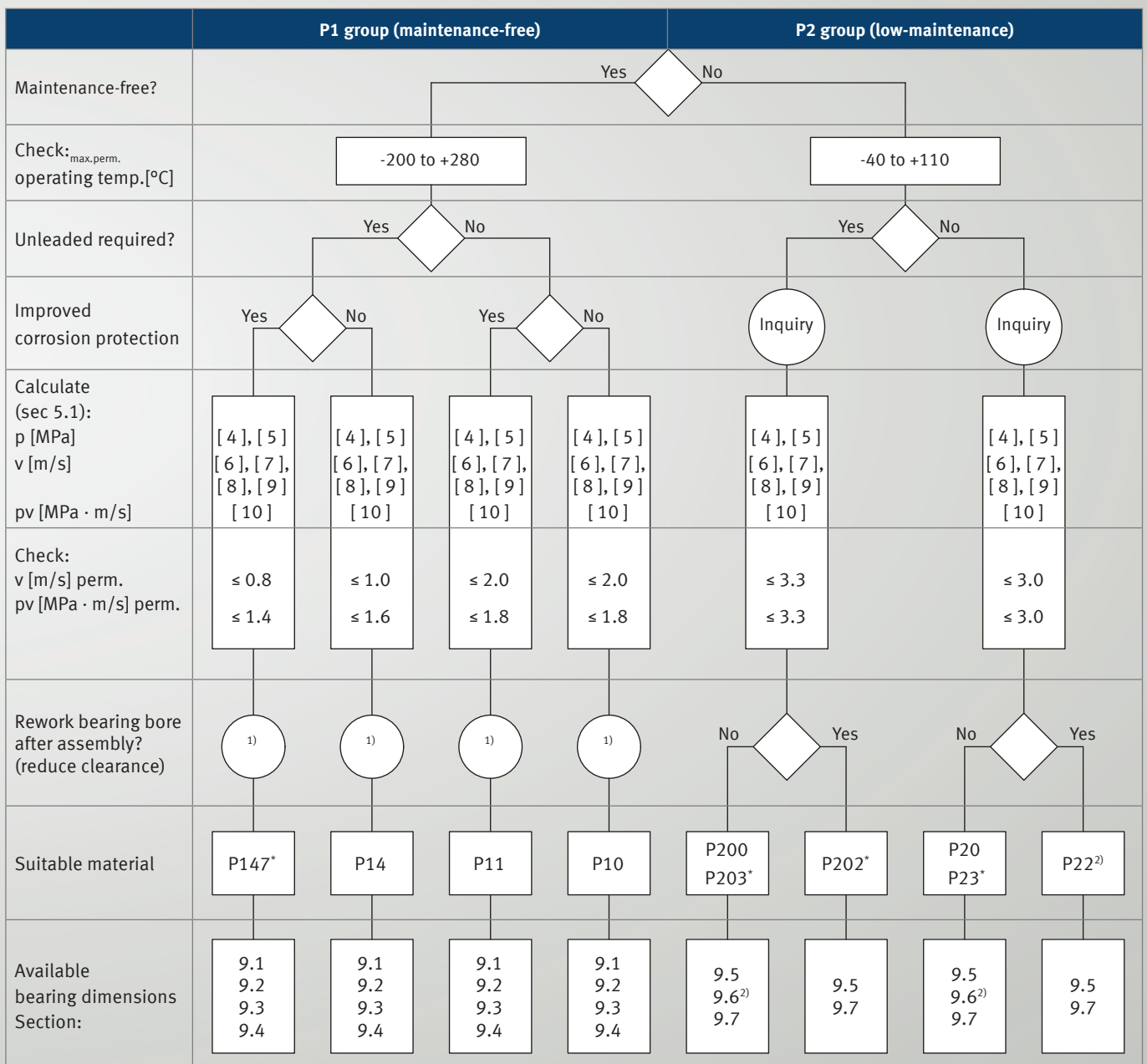

¹⁾ P1 group bushes cannot be remachined. They can be calibrated without cutting, but this reduces service life (Tab. 37)

²⁾ Applies to P20/P200 material only

* On request

4.1 P1 plain bearings

4.1.1 P10, P11 ... maintenance-free and robust

Brief description

P10 and P11 are leaded, robust sliding materials with maximum tribological performance. They are designed for maintenance-free, dry-running applications, but can also be employed in systems with liquid lubrication. The use of grease as a lubricant with P10 or P11 is only possible to a limited extent, and is not recommended.

Material manufacture

The solid lubricant mass is produced in a specially adapted mixing process. In a parallel, continuous sintering operation, bronze powder is sintered onto the steel or bronze back as a sliding layer. This produces a sliding layer with a thickness from 0.2 mm to 0.35 mm and a pore volume of approx. 30%. Next, the cavities are filled with solid lubricant by means of impregnating rollers. This process step is controlled in such a way that a running-in layer of solid lubricant up to max. 0.03 mm thick is produced above the sliding layer. In further thermal treatments, the characteristic properties of the material system are adjusted, and the required thickness tolerances of the composite material are produced using controlled roller pairs.

Plain bearing production

Sliding elements in a great variety of designs are produced from P10 and P11 in cutting, stamping and shaping processes.

Standard designs are:

- Cylindrical bushes
- Flange bushes
- Thrust washers
- Strips

In a final step, plain bearings manufactured from P10 undergo corrosion protection treatment on the bearing back, face reliefs and striking faces.

Standard version: Tin

Layer thickness: approx. 0.002 mm

Additionally, P10 plain bearings can be supplied with improved corrosion protection coating "Zinc, transparent passivated", on request.

P11 does not require any additional corrosion protection.

Note:



Tin is used as temporary corrosion protection and an assembly aid.

Characteristics of P10

- Very low stick-slip tendency
- Low wear
- Good chemical resistance
- Low friction value
- No tendency to fuse with metal
- Largely resistant to swelling
- Does not absorb water

Preferred areas of application

- Maintenance-free operation under dry-running conditions
- Rotating or oscillating movements up to a speed of 2 m/s
- Linear movements
- Temperature range -200 °C to 280 °C

Characteristics of P11

Material P11 is recommended for more stringent requirements in terms of corrosion resistance or for use in aggressive media.

It has some advantages over P10 in this respect:

- Very good thermal conductivity and therefore greater operational safety
- Anti-magnetic

Hydrodynamic operation

Use in hydrodynamic conditions is possible without problems up to a sliding speed of 3 m/s.

In continuous operation above 3 m/s, there is a risk of flow erosion or cavitation. Motorservice offers the calculation of hydrodynamic operating states as a service

The materials P10 and P11 contain lead and must not be used in the food sector.

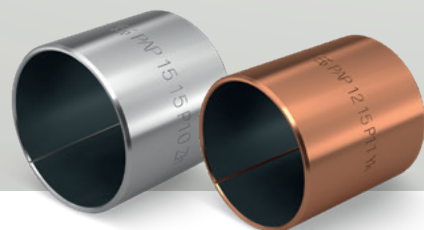

Material composition P10

1	Running-in layer		
	PTFE matrix with bulking agent ¹⁾	Layer thickness [mm]:	max. 0.03
2	Sliding layer		
	Tin-lead-bronze	Layer thickness [mm]:	0.20-0.35
		Pore volume [%]:	approx. 30
3	Bearing back		
	Steel	Steel thickness [mm]:	Variable
		Steel hardness [HB]:	100-180

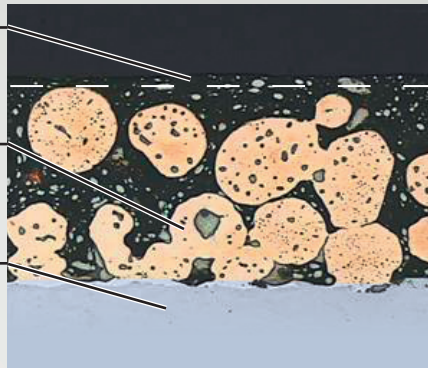

Tab. 4: System composition P10

Fig. 15: Layer system P10

Running-in layer	
Components	% weight
PTFE	44
Pb	56
Sliding layer	
Components	% weight
Sn	9 to 11
Pb	9 to 11
Cu	Remainder
Bearing back	
Material	Material information
Steel	DC04
	DIN EN 10130
	DIN EN 10139

Tab. 5: Chemical composition P10

Characteristic values, load limit	Designation	Unit	Value
Permitted pv value	$p_{perm.}$	MPa · m/s	1.8
Permitted specific bearing stress			
• Static	$p_{perm.}$	MPa	250
• Concentrated load, circumferential load at sliding speed ≤ 0.013 m/s	$p_{perm.}$	MPa	140
• Concentrated load, circumferential load at sliding speed ≤ 0.032 m/s	$p_{perm.}$	MPa	56
• Concentrated load, circumferential load, increasing at sliding speed ≤ 0.064 m/s	$p_{perm.}$	MPa	28
Permitted sliding speed			
• Dry running at $p \leq 0.90$ MPa	$v_{perm.}$	m/s	2
• Hydrodynamic operation	$v_{perm.}$	m/s	3
Permitted temperature	$T_{perm.}$	°C	-200 to +280
Coefficient of thermal expansion			
• Steel back	α_{St}	K ⁻¹	$11 \cdot 10^{-6}$
Coefficient of thermal conductivity			
• Steel back	λ_{St}	W(mK) ⁻¹	40

Tab. 6: Material characteristics P10

¹⁾ The pores of the sliding layer are also filled with this lubricant mass.

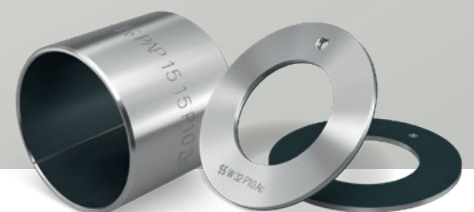

4 | Material selection, material information

Material composition P11

1	Running-in layer	
	PTFE matrix with bulking agent ¹⁾	
	Layer thickness [mm]:	max. 0.03
2	Sliding layer	
	Tin-bronze	
	Layer thickness [mm]:	0.20-0.35
	Pore volume [%]:	approx. 30
3	Bearing back	
	Bronze	
	Bronze thickness [mm]:	Variable
	Bronze hardness [HB]:	80-160

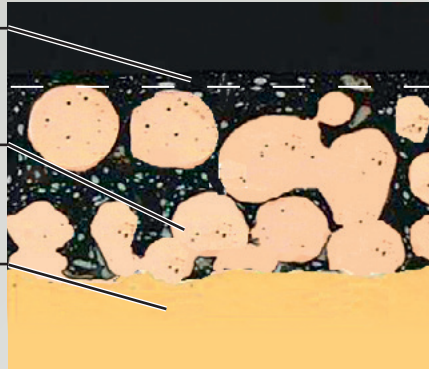

Fig. 16: Layer system P11

Tab. 7: System composition P11

Running-in layer	
Components	% weight
PTFE	44
Pb	56
Sliding layer	
Components	% weight
Sn	9 to 11
Cu	Remainder
Bearing back	
Material	Material information
Bronze	CuSn 6
	DIN 17662

Tab. 8: Chemical composition P11

Characteristic values, load limit	Designation	Unit	Value
Permitted pv value	$p_{perm.}$	MPa · m/s	1.8
Permitted specific bearing stress			
• Static	$p_{perm.}$	MPa	250
• Dynamic	$p_{perm.}$	MPa	140
• Concentrated load, circumferential load at sliding speed ≤ 0.013 m/s	$p_{perm.}$	MPa	140
• Concentrated load, circumferential load at sliding speed ≤ 0.032 m/s	$p_{perm.}$	MPa	56
• Concentrated load, circumferential load, increasing at a sliding speed of ≤ 0.064 m/s	$p_{perm.}$	MPa	28
Permitted speed			
• Dry running at $p \leq 0.90$ MPa	$v_{perm.}$	m/s	2
• Hydrodynamic operation	$v_{perm.}$	m/s	3
Permitted temperature	$T_{perm.}$	°C	-200 to +280
Coefficient of thermal expansion			
• Bronze back	α_{Bz}	K ⁻¹	$17 \cdot 10^{-6}$
Coefficient of thermal conductivity			
• Bronze back	λ_{Bz}	W(mK) ⁻¹	≤ 70

Tab. 9: Material characteristics P11

¹⁾ The pores of the sliding layer are also filled with this lubricant mass.



4.1.2 P14 ... Maintenance-free and environmentally friendly

Brief description

P14 is an unleaded special sliding material with a high tribological performance. It is designed for maintenance-free, dry-running applications, particularly in areas subject to increased corrosion. It may also be employed in systems with liquid lubrication, however. The use of grease as a lubricant with P14 is only possible to a limited extent, and is not recommended.

Material manufacture

The solid lubricant mass is produced in a specially adapted mixing process. In a parallel, continuous sintering operation, bronze powder is sintered onto the steel back as a sliding layer. This produces a sliding layer with a thickness from 0.2 mm to 0.35 mm and a pore volume of approx. 30%. Next, the cavities are filled with solid lubricant by means of impregnating rollers. This process step is controlled in such a way that a running-in layer of solid lubricant up to max. 0.03 mm thick is produced above the sliding layer. In further thermal treatments, the characteristic properties of the material system are adjusted, and the required thickness tolerances of the composite material are produced using controlled roller pairs.

Plain bearing production

Sliding elements in a great variety of designs are produced from P14 in cutting, stamping and shaping processes. Standard designs are:

- Cylindrical bushes
- Flange bushes
- Thrust washers
- Strips

In a final step, plain bearings manufactured from P14 undergo anti-corrosion treatment on the bearing back, face reliefs and striking faces.

Standard version: Tin

Layer thickness: approx. 0.002 mm

Properties of P14

- Unleaded
- Compliant with Directive 2002/95/EC (RoHS)
- Very low stick-slip tendency
- Low wear
- Low friction value
- No tendency to fuse with metal
- Very low tendency to swell

Preferred areas of application

- Maintenance-free operation in dry-running conditions where unleaded parts are required
- Rotating or oscillating movements up to a speed of 1 m/s
- Linear movements
- Temperature range -200 °C to 280 °C

Hydrodynamic operation

Use in hydrodynamic conditions is possible without problems up to a sliding speed of 3 m/s.

In continuous operation above 3 m/s, there is a risk of flow erosion or cavitation.

Motorservice offers the calculation of hydrodynamic operating states as a service



Note:

Tin is used as temporary corrosion protection and an assembly aid.

P14 cannot be used in water
(alternative: P10, P11, P147)

4 | Material selection, material information

Material composition P14

1 Running-in layer		
PTFE matrix with bulking agent ¹⁾	Layer thickness [mm]:	max. 0.03
2 Sliding layer		
Tin-bronze	Layer thickness [mm]:	0.20-0.35
	Pore volume [%]:	approx. 30
3 Bearing back		
Steel	Steel thickness [mm]:	Variable
	Steel hardness [HB]:	100-180

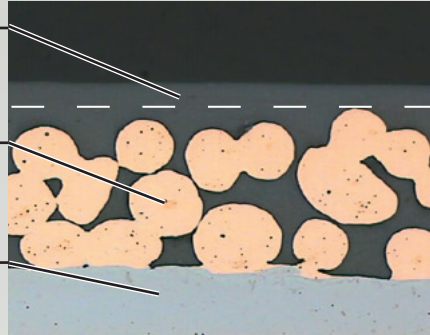

Fig. 17: Layer system

Tab. 10: System composition

Running-in layer	
Components	% weight
PTFE	62
ZnS	38
Sliding layer	
Components	% weight
Sn	9 to 11
Cu	Remainder
Bearing back	
Material	Material information
Steel	DC04
	DIN EN 10130
	DIN EN 10139

Tab. 11: Chemical composition

Characteristic values, load limit	Designation	Unit	Value
Permitted pv value	$p v_{perm.}$	MPa · m/s	1.6
Permitted specific bearing stress			
• Static	$p_{perm.}$	MPa	250
• Concentrated load, circumferential load at sliding speed ≤ 0.011 m/s	$p_{perm.}$	MPa	140
• Concentrated load, circumferential load at sliding speed ≤ 0.029 m/s	$p_{perm.}$	MPa	56
• Concentrated load, circumferential load, increasing at sliding speed ≤ 0.057 m/s	$p_{perm.}$	MPa	28
Permitted sliding speed			
• Dry running at $p \leq 1.60$ MPa	$v_{perm.}$	m/s	1
• Hydrodynamic operation	$v_{perm.}$	m/s	3
Permitted temperature	$T_{perm.}$	°C	-200 to +280
Coefficient of thermal expansion			
• Steel back	α_{St}	K ⁻¹	$11 \cdot 10^{-6}$
Coefficient of thermal conductivity			
• Steel back	λ_{St}	W(mK) ⁻¹	40

Tab. 12: Material characteristics P14

¹⁾ The pores of the sliding layer are also filled with this lubricant mass.

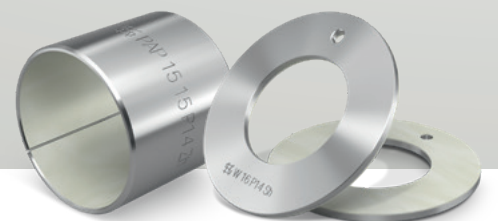

4.1.2 P147 ... Maintenance-free and corrosion-resistant

Brief description

P147 is an unleaded special sliding material with a high tribological performance. It is designed for maintenance-free, dry-running applications, particularly in areas subject to increased corrosion. It may also be used in systems with liquid lubrication. The use of grease as a lubricant with P147 is only possible to a limited extent, and is not recommended.

Material manufacture

The solid lubricant mass is produced in a specially adapted mixing process. In a parallel, continuous sintering operation, bronze powder is sintered onto the steel back as a sliding layer. This produces a sliding layer with a thickness from 0.2 mm to 0.35 mm and a pore volume of approx. 30%. Next, the cavities are filled with solid lubricant by means of impregnating rollers. This process step is controlled in such a way that a running-in layer of solid lubricant up to max. 0.03 mm thick is produced above the sliding layer. In further thermal treatments, the characteristic properties of the material system are adjusted, and the required thickness tolerances of the composite material are produced using controlled roller pairs.

Plain bearing production

Sliding elements in a great variety of designs are produced from P147 in cutting, stamping and shaping processes. Standard designs are:

- Cylindrical bushes
- Flange bushes
- Thrust washers
- Strips

In a final step, plain bearings manufactured from P147 undergo special anti-corrosion treatment on the bearing back, face reliefs and striking faces.

- Standard version: Tin
Layer thickness: approx. 0.002 mm
- Increased corrosion protection requirements (on request)
Version: Zinc, transparent passivated
Layer thickness: 0.008 mm to 0.012 mm
Higher layer thickness available on request.

Properties of P147

- Unleaded
- Compliant with Directive 2002/95/EC (RoHS)
- Very low stick-slip tendency
- Low wear
- Good chemical resistance
- Low friction value
- No tendency to fuse with metal
- Very low tendency to swell
- Does not absorb water
- Very good corrosion resistance

Preferred areas of application

- In aggressive media¹⁾
- Outside machines and systems¹⁾
- Maintenance-free operation in dry-running conditions where unleaded parts are required
- Rotating or oscillating movements up to a speed of 0.8 m/s
- Linear movements
- Temperature range -200 °C to 280 °C

Hydrodynamic operation

Use in hydrodynamic conditions is possible without problems up to a sliding speed of 3 m/s.

In continuous operation above 3 m/s, there is a risk of flow erosion or cavitation. Motorservice offers the calculation of hydrodynamic operating states as a service

Note:

Transparent passivated zinc is an especially effective anti-corrosion agent. An inclined mounting of the bush must be avoided during installation (press-in procedure) of the bearing bushes, as there is a risk of damaging the zinc coating.

Note:

The material P147 is available on request.

¹⁾ P147 satisfies the requirements of the salt spray test to DIN 50021

4 | Material selection, material information

Material composition P147

1	Running-in layer	
	PTFE matrix with bulking agent ¹⁾	
	Layer thickness [mm]:	max. 0.03
2	Sliding layer	
	Tin-bronze	
	Layer thickness [mm]:	0.20-0.35
	Pore volume [%]:	approx. 30
3	Bearing back	
	Steel	
	Steel thickness [mm]:	Variable
	Steel hardness [HB]:	100-180

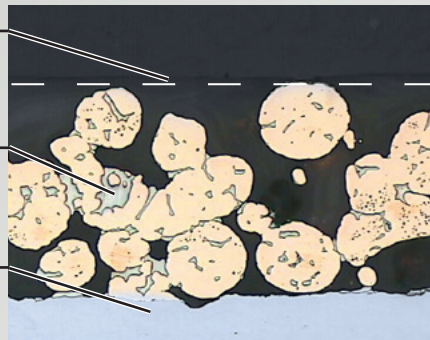

Fig. 18: Layer system

Tab. 13: System composition

Running-in layer	
Components	% weight
PTFE	82
BaSO ₄	18
Sliding layer	
Components	% weight
Sn	9 to 11
Cu	Remainder
Material	Material information
Steel	DC04
	DIN EN 10130
	DIN EN 10139

Tab. 14: Chemical composition

Characteristic values, load limit	Designation	Unit	Value
Permitted pv value	$p_{v,perm.}$	MPa · m/s	1.4
Permitted specific bearing stress			
• Static	$p_{perm.}$	MPa	250
• Concentrated load, circumferential load at sliding speed ≤ 0.010 m/s	$p_{perm.}$	MPa	140
• Concentrated load, circumferential load at sliding speed ≤ 0.025 m/s	$p_{perm.}$	MPa	56
• Concentrated load, circumferential load, increasing at sliding speed ≤ 0.050 m/s	$p_{perm.}$	MPa	28
Permitted sliding speed			
• Dry running at $p \leq 1.75$ MPa	$v_{perm.}$	m/s	0.8
Permitted temperature	$T_{perm.}$	°C	-200 to +280
Coefficient of thermal expansion			
• Steel back	α_{St}	K ⁻¹	$11 \cdot 10^{-6}$
Coefficient of thermal conductivity			
• Steel back	λ_{St}	W(mK) ⁻¹	40

Tab. 15: Material characteristics P147

¹⁾ The pores of the sliding layer are also filled with this lubricant mass.

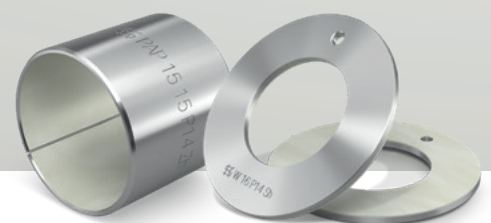

4.2 P2 plain bearings

4.2.1 P20, P22, P23 ... low-maintenance standard solutions

Brief description

P20, P22 and P23 are leaded standard sliding materials with a high performance. They are designed for low-maintenance grease or liquid-lubricated applications. The standard P20 version features oil distributing pockets to DIN ISO 3547 in the sliding surface and a pre-finished wall thickness. The P22 versions (smooth sliding surface, suitable for remachining) and P23 (smooth sliding surface, ready to install) are also available on request.

Material manufacture

The bronze compound layer is sintered onto a prepared steel surface (strip) in a continuous sintering process in such a way as to produce a pore volume of around 50 % at a layer thickness of approx. 0.3 mm. Next, the sliding layer is applied in powder form and rolled into the cavities in the compound layer under a high temperature. The result is a sliding layer thickness of approx. 0.08 mm or approx. 0.2 mm above the compound layer, depending on the intended purpose. At the same time, the oil distributing pockets are produced, if required. A further rolling calibration process ensures the necessary thickness tolerance of the composite.

Plain bearing production

Sliding elements in a great variety of designs are produced from the composite material in cutting, stamping and shaping processes.

Standard designs are:

- Cylindrical bushes
- Thrust washers
- Strips

Plain bearings manufactured from P20, P22 or P23 undergo corrosion protection treatment on the bearing back, face reliefs and striking faces.

Standard version: Tin

Layer thickness [mm]: approx. 0.002



Note:

Tin is used as temporary corrosion protection and an assembly aid.

Characteristics

- Lifetime lubrication possible
- Low wear
- Low sensitivity to edge loading
- Good damping characteristics
- Insensitive to impact loads
- Good chemical resistance

Preferred areas of application

- Low-maintenance operation with lubrication
- Rotating and oscillating movements up to a speed of 3 m/s
- Linear movements up to 6 m/s
- Temperature range -40 °C to 110 °C

The materials P20, P22 and P23 contain lead and must not be used in the food sector.

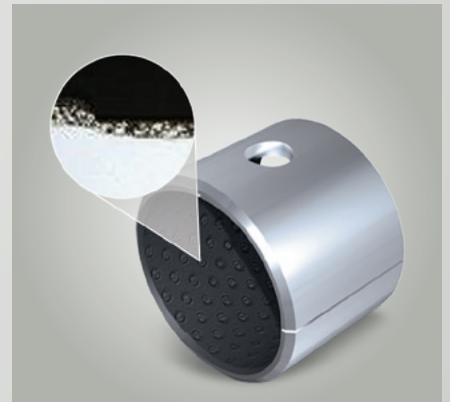

Fig. 19: P20 plain bearing with oil distributing pockets and oil hole

Material	Versions		
	Ready to install	Oil distributing pockets	Machining allowance
P20	•	•	
P22			•
P23	•		

Tab. 16: Material versions P22 and P23 available on request

P22 and P23 feature smooth sliding surfaces and can be used under hydrodynamic conditions. The bearing bore of P22 is suitable for remachining.

Motorservice offers the calculation of hydrodynamic operating states as a service.



Note:

Materials P22 and P23 are available on request.

4 | Material selection, material information

Material composition P20, P22, P23

1	Sliding layer	
	PVDF matrix with bulking agents ¹⁾ Layer thickness [mm]:	0.08-0.20
2	Intermediate layer	
	Tin-bronze Layer thickness [mm]: Pore volume [%]:	0.20-0.35 approx. 50
3	Bearing back	
	Steel Steel thickness [mm]: Steel hardness [HB]:	Variable 100-180

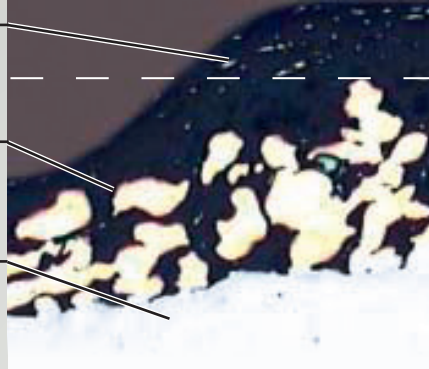

Tab. 17: System composition

Fig. 20: Layer system

Sliding layer	
Components	% weight
PVDF	51
PTFE	8
Pb	41
Intermediate layer	
Components	% weight
Sn	9 to 11
Cu	Remainder
Bearing back	
Material	Material information
Steel	DC04
	DIN EN 10130
	DIN EN 10139

Tab. 18: Chemical composition

Characteristic values, load limit	Designation	Unit	Value
Permitted pv value	$p_{v,perm.}$	MPa · m/s	3
Permitted specific bearing stress			
• Static	$p_{perm.}$	MPa	250
• Concentrated load, circumferential load at sliding speed ≤ 0.021 m/s	$p_{perm.}$	MPa	140
• Concentrated load, circumferential load at sliding speed ≤ 0.043 m/s	$p_{perm.}$	MPa	70
• Concentrated load, circumferential load, increasing at sliding speed ≤ 0.086 m/s	$p_{perm.}$	MPa	35
Permitted sliding speed			
• Grease-lubricated, rotating, oscillating	$v_{perm.}$	m/s	3
• Grease-lubricated, linear	$v_{perm.}$	m/s	6
• Hydrodynamic operation	$v_{perm.}$	m/s	6
Permitted temperature	$T_{perm.}$	°C	-40 to +110
Coefficient of thermal expansion			
• Steel back	α_{St}	K ⁻¹	$11 \cdot 10^{-6}$
Coefficient of thermal conductivity			
• Steel back	λ_{St}	W(mK) ⁻¹	40

Tab. 19: Material characteristics P20, P22, P23

¹⁾ The cavities of the intermediate sliding layer are also filled with this mass.



4.2.2 P200, P202, P203 ... low-maintenance, universal

Brief description

P200, P202 and P203 are unleaded, environmentally friendly sliding materials with a very high performance. Thanks to a special combination of bulking agents, high wear resistance is achieved with simultaneously very good dry-running behaviour. They are therefore ideally suited to low-maintenance grease or liquid-lubricated applications subject to more stringent requirements. The standard P200 version features oil distributing pockets to DIN ISO 3547 in the sliding surface and a pre-finished wall thickness. The P202 versions (smooth sliding surface, suitable for remachining) and P203 (smooth sliding surface, ready to install) are also available on request.

Material manufacture

The bronze compound layer is sintered onto a prepared steel surface (strip) in a continuous sintering process in such a way as to produce a pore volume of around 50 % at a layer thickness of approx. 0.3 mm. Next, the sliding layer is applied in powder form and rolled into the cavities in the compound layer under a high temperature. The result is a sliding layer thickness of approx. 0.08 mm or approx. 0.2 mm above the compound layer, depending on the intended purpose. At the same time, the oil distributing pockets are produced, if required. A further rolling calibration process ensures the necessary thickness tolerance of the composite.

Material	Versions		
	Ready to install	Oil distributing pockets	Machining allowance
P200	•	•	
P202			•
P203	•		

Tab. 20: Material versions P202 and P203 available on request

Plain bearing production

Sliding elements in a great variety of designs are produced from the composite material in cutting, stamping and shaping processes.

Standard designs are:

- Cylindrical bushes
- Thrust washers
- Strips

Plain bearings manufactured from P200, P202 or P203 undergo corrosion protection treatment on the bearing back, face reliefs and striking faces.

Standard version: Tin

Layer thickness [mm]: approx. 0.002
Additionally, the plain bearings can be supplied with improved corrosion protection coating "Zinc, transparent passivated", on request.



Note:

Tin is used as temporary corrosion protection and an assembly aid.

Characteristics

- Lifetime lubrication
- Low wear
- Very good dry-running properties
- Insensitive to edge loading and impacts
- Good damping characteristics
- Good chemical resistance
- Unleaded
- Compliant with Directive 2002/95/EC (RoHS)

Preferred areas of application

- Food sector
- Special requirements for environmental protection
- Low-maintenance operating with lubrication, more stringent requirements
- Rotating and oscillating movements up to a sliding speed of 3.3 m/s
- Linear movements up to 6 m/s
- Temperature range -40 °C to 110 °C



Fig. 21: P200 – Plain bearings with oil distributing pocket and oil hole

P202 and P203 feature smooth sliding surfaces and can be used under hydrodynamic conditions. P202 is suitable for remachining.

Motorservice offers the calculation of hydrodynamic operating states as a service.



Note:

Materials P202 and P203 are available on request.

4 | Material selection, material information

Material composition P200, P202, P203

1	Sliding layer	
	PVDF matrix with bulking agents ¹⁾ Layer thickness [mm]:	0.08-0.20
2	Intermediate layer	
	Tin-bronze Layer thickness [mm]: Pore volume [%]:	0.20-0.35 approx. 50
3	Bearing back	
	Steel Steel thickness [mm]: Steel hardness [HB]:	Variable 100-180

Tab. 21: System composition

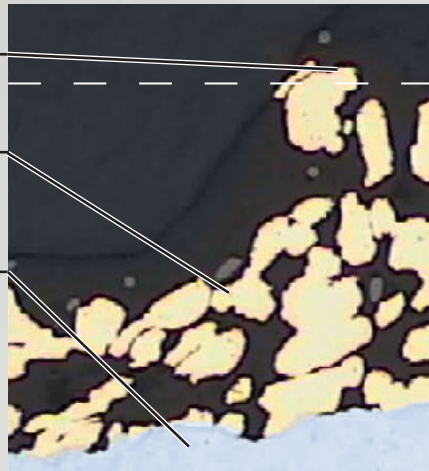

Fig. 22: Layer system

Sliding layer	
Components	% weight
PTFE	9 to 12
Wear and friction-reducing bulking agents	22 to 26
PVDF	Remainder
Intermediate layer	
Components	% weight
Sn	9 to 11
P	max. 0.05
Other	max. 0.05
Cu	Remainder
Bearing back	
Material	Material information
Steel	DC04
	DIN EN 10130
	DIN EN 10139

Tab. 22: Chemical composition

Characteristic values, load limit	Designation	Unit	Value
Permitted pv value	$p_{v,perm.}$	MPa · m/s	3.3
Permitted specific bearing stress			
• Static	$p_{perm.}$	MPa	250
• Concentrated load, circumferential load at sliding speed ≤ 0.024 m/s	$p_{perm.}$	MPa	140
• Concentrated load, circumferential load at sliding speed ≤ 0.047 m/s	$p_{perm.}$	MPa	70
• Concentrated load, circumferential load, increasing at sliding speed ≤ 0.094 m/s	$p_{perm.}$	MPa	35
Permitted sliding speed			
• Grease-lubricated, rotating, oscillating	$v_{perm.}$	m/s	3.3
• Grease-lubricated, linear	$v_{perm.}$	m/s	6
• Hydrodynamic operation	$v_{perm.}$	m/s	6
Permitted temperature	$T_{perm.}$	°C	-40 to +110
Coefficient of thermal expansion			
• Steel back	α_{St}	K ⁻¹	$11 \cdot 10^{-6}$
Coefficient of thermal conductivity			
• Steel back	λ_{St}	W(mK) ⁻¹	40

Tab. 23: Material characteristics P200, P202, P203

¹⁾ The cavities of the intermediate sliding layer are also filled with this mass.

5.1 Service life calculation formulae

Based on the above information about the influences on the service life and operational safety of KS PERMAGLIDE®

plain bearings, the equations below can be used to achieve an estimate of the expected service life.

Nominal service life L_N for maintenance-free P1 plain bearings

[1] Movement: rotating, oscillating
$$L_N = \frac{400}{(pv)^{1.2}} f_A \cdot f_p \cdot f_v \cdot f_T \cdot f_w \cdot f_R \quad [h]$$

[2] Movement: linear
$$L_N = \frac{400}{(pv)^{1.2}} f_A \cdot f_p \cdot f_v \cdot f_T \cdot f_w \cdot f_R \cdot f_L \quad [h]$$

Nominal service life L_N for low-maintenance, grease-lubricated P2 plain bearings

[3] Movement: rotating, oscillating
$$L_N = \frac{2000}{(pv)^{1.5}} f_A \cdot f_p \cdot f_v \cdot f_T \cdot f_w \cdot f_R \quad [h]$$

Movement: linear

The calculation of the nominal service life during linear movement under lubrication is not particularly useful due to influences which cannot be precisely recorded (e.g. soiling, ageing of lubricant etc.). Motorservice offers an advisory service here, based on practical experience.

[4] Specific bearing stress, bush
$$p = \frac{F}{D_i \cdot B} \quad [MPa]$$

[5] Specific bearing stress, thrust washer
$$p = \frac{4 \cdot F}{(D_o^2 - D_i^2) \cdot \pi} \quad [MPa]$$

[6] Sliding speed, bush rotating
$$v = \frac{D_i \cdot \pi \cdot n}{60 \cdot 10^3} \quad [m/s]$$

[7] Sliding speed, thrust washer, rotating
$$v = \frac{D_o \cdot \pi \cdot n}{60 \cdot 10^3} \quad [m/s]$$

5 | Nominal service life calculation

[8] Sliding speed, bush, oscillating
$$v = \frac{D_i \cdot \pi}{60 \cdot 10^3} \cdot \frac{2\varphi \cdot n_{osz}}{360^\circ} \quad [\text{m/s}]$$

[9] Sliding speed, thrust washer, oscillating
$$v = \frac{D_o \cdot \pi}{60 \cdot 10^3} \cdot \frac{2\varphi \cdot n_{osz}}{360^\circ} \quad [\text{m/s}]$$

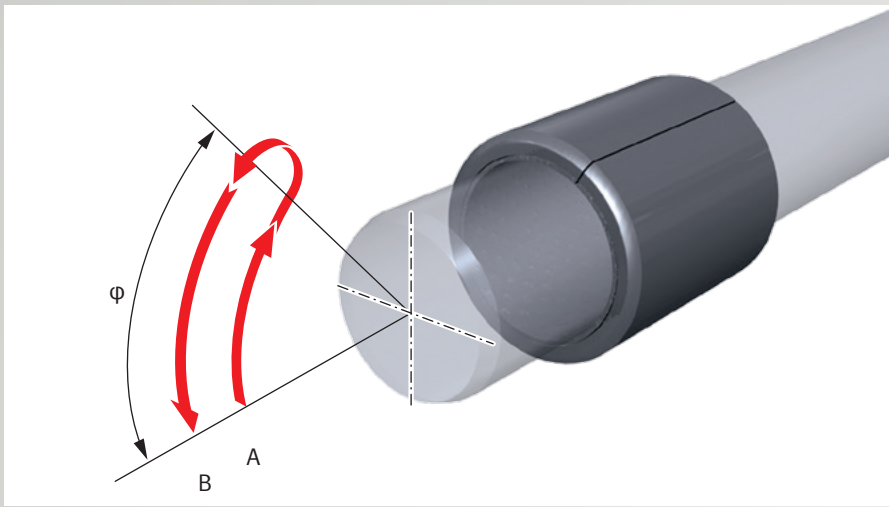

Fig. 23: Swivel angle φ
The oscillating frequency n_{osz} is the number of movements from A to B per minute.

[10] Calculation of pv value
$$pv = p \text{ [MPa]} \cdot v \text{ [m/s]} \quad [\text{MPa} \cdot \text{m/s}]$$

$p v_{perm.}$ for P10, P11 $\leq 1.8 \text{ MPa} \cdot \text{m/s}$
P14 $\leq 1.6 \text{ MPa} \cdot \text{m/s}$
P147 $\leq 1.4 \text{ MPa} \cdot \text{m/s}$
P20 $\leq 3.0 \text{ MPa} \cdot \text{m/s}$
P200 $\leq 3.3 \text{ MPa} \cdot \text{m/s}$

Correction factors	P1	P2
f_p = specific bearing stress	Fig. 24	Fig. 28
f_t = temperature	Fig. 25	Fig. 29
f_v = sliding speed	Fig. 26	Fig. 30
f_R = roughness depth	Fig. 27	Fig. 31
f_A = load type	Fig. 32	Fig. 32
f_w = material	Tab. 24	Tab. 24
f_L = linear movement [11]	Fig. 33	---

Correction factors for P10, P11, P14 and P147*

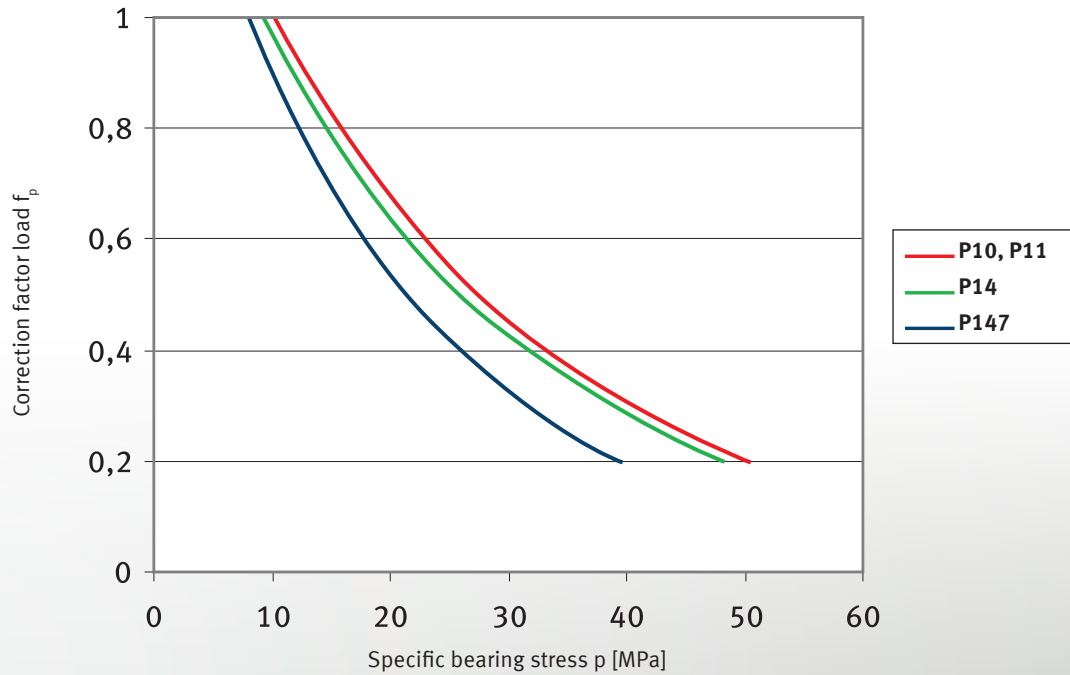

Fig. 24: Correction factor load f_p

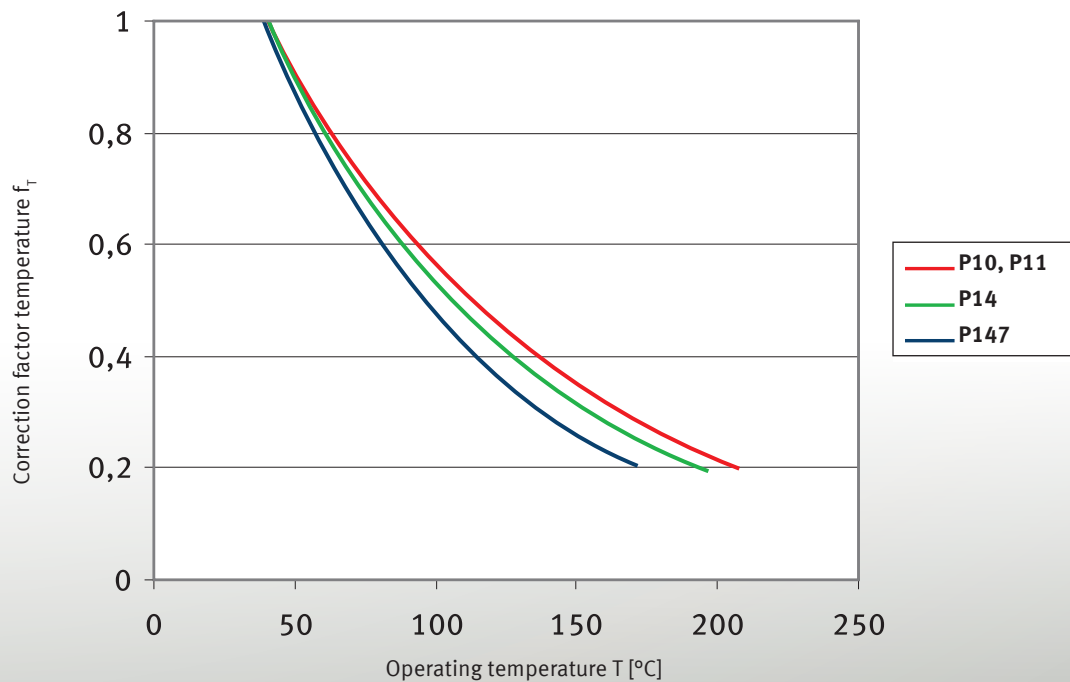

Fig. 25: Correction factor temperature f_T

* On request

5 | Nominal service life calculation

Correction factors for P10, P11, P14 and P147*

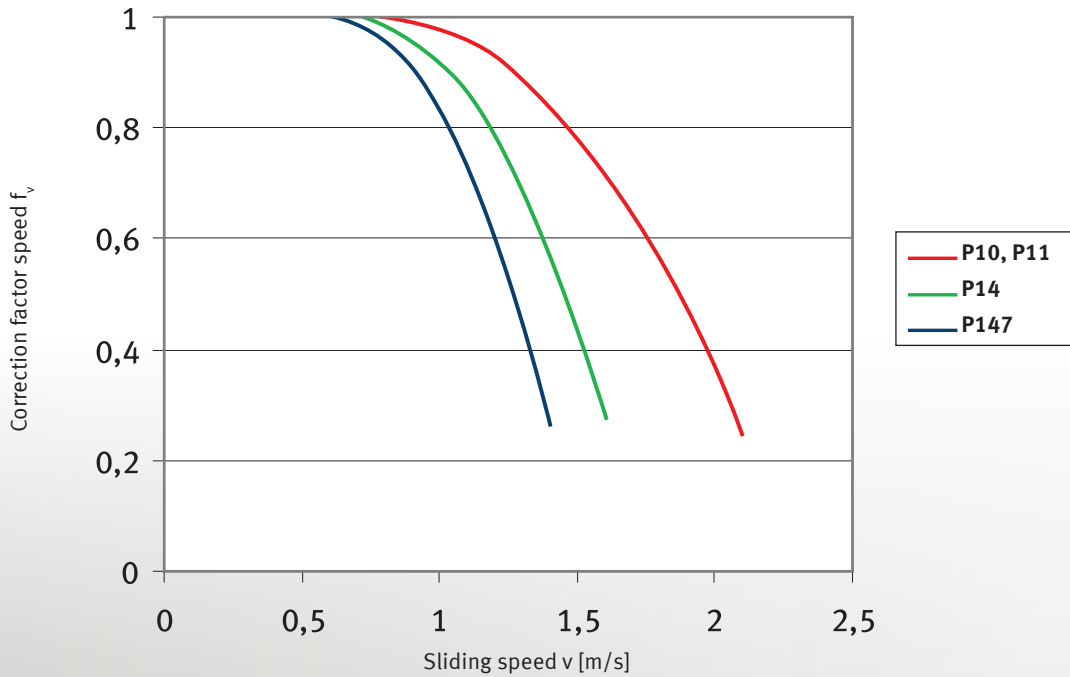

Fig. 26: Correction factor sliding speed f_v

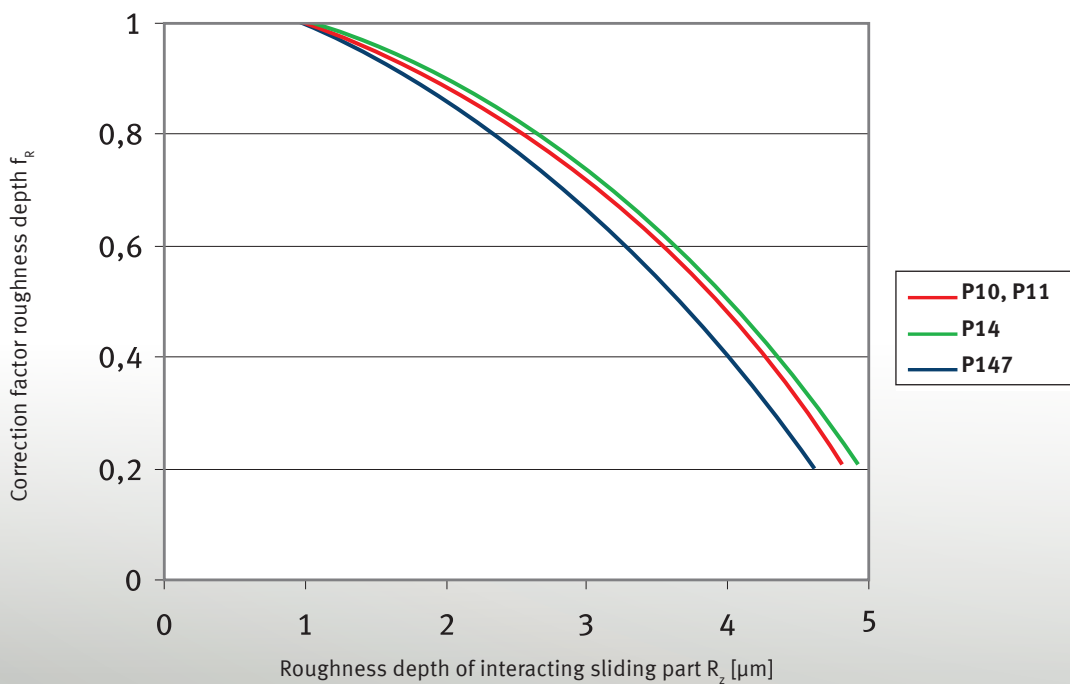

Fig. 27: Correction factor roughness depth f_R

* On request

Correction factors for P20, P22*, P23* and P200, P202*, P203*

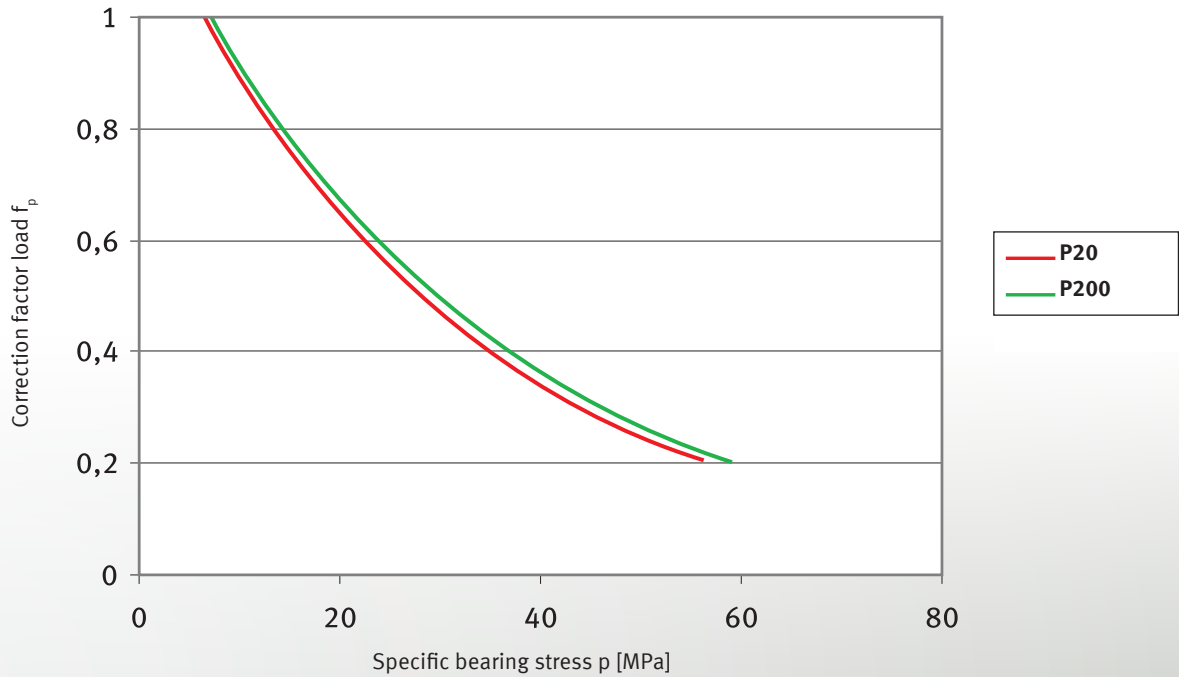

Fig. 28: Correction factor load f_p

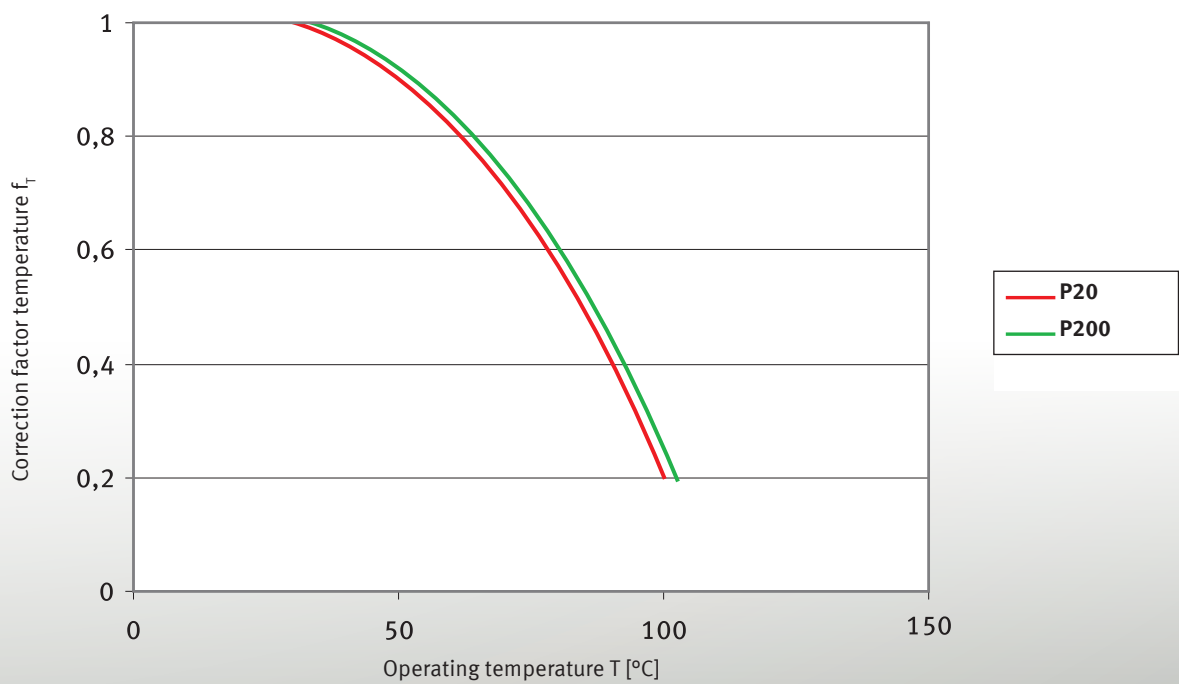

Fig. 29: Correction factor temperature f_T

* On request

5 | Nominal service life calculation

Correction factors for P20, P22*, P23* and P200, P202*, P203*

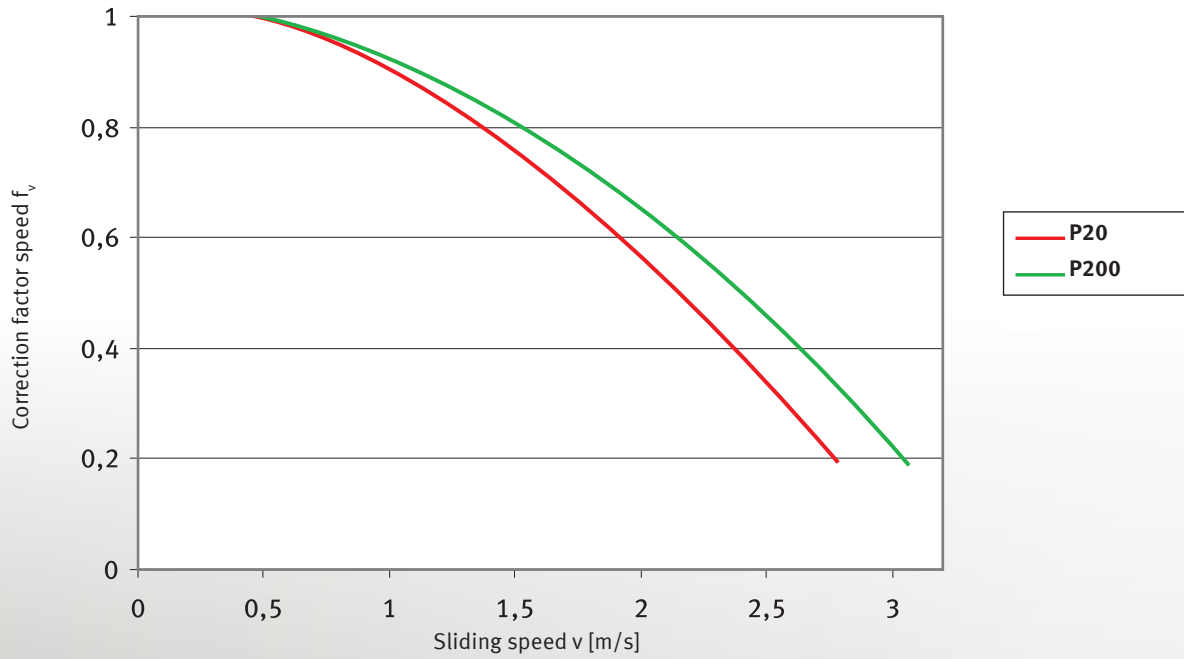

Fig. 30: Correction factor sliding speed f_v

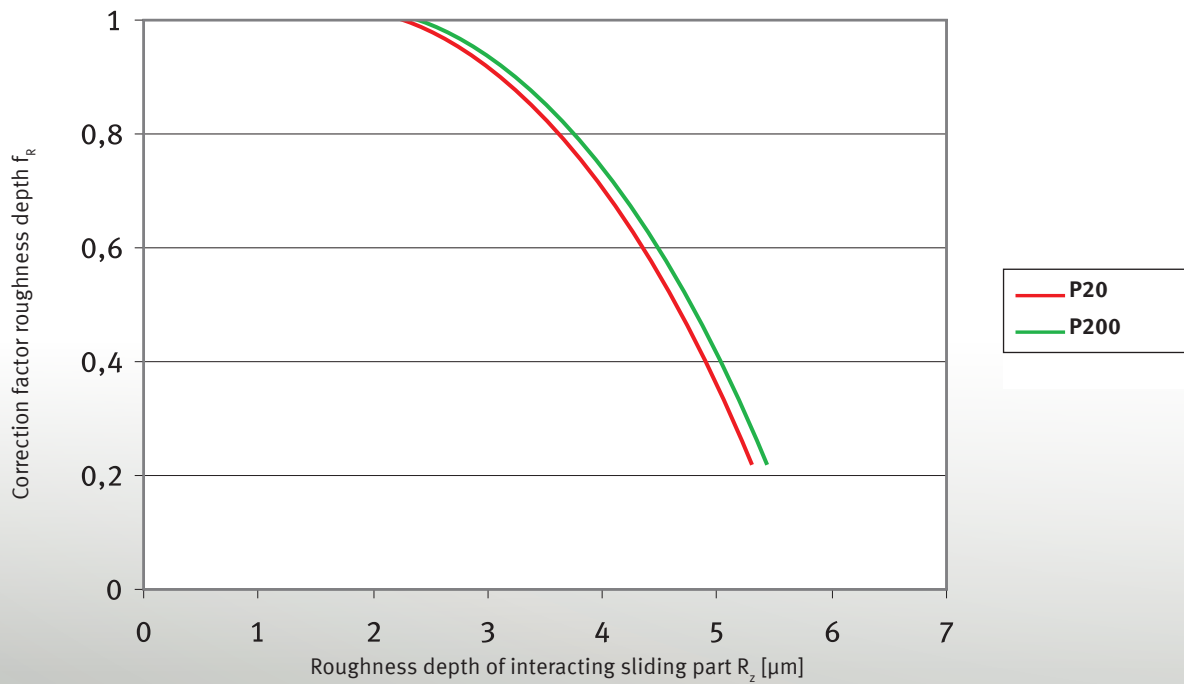

Fig. 31: Correction factor roughness depth f_R

* On request

Load type correction factor

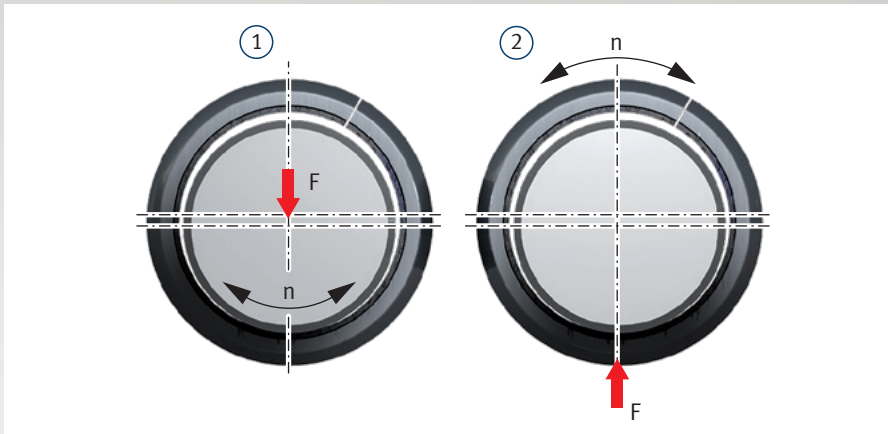

Fig. 32: Correction factor stress f_A

No. (see Fig. 32)	Load type	f_A
1	Concentrated load	1
2	Circumferential load	2
-	Axial load	1
-	Linear movement	1

Linear movement correction factor

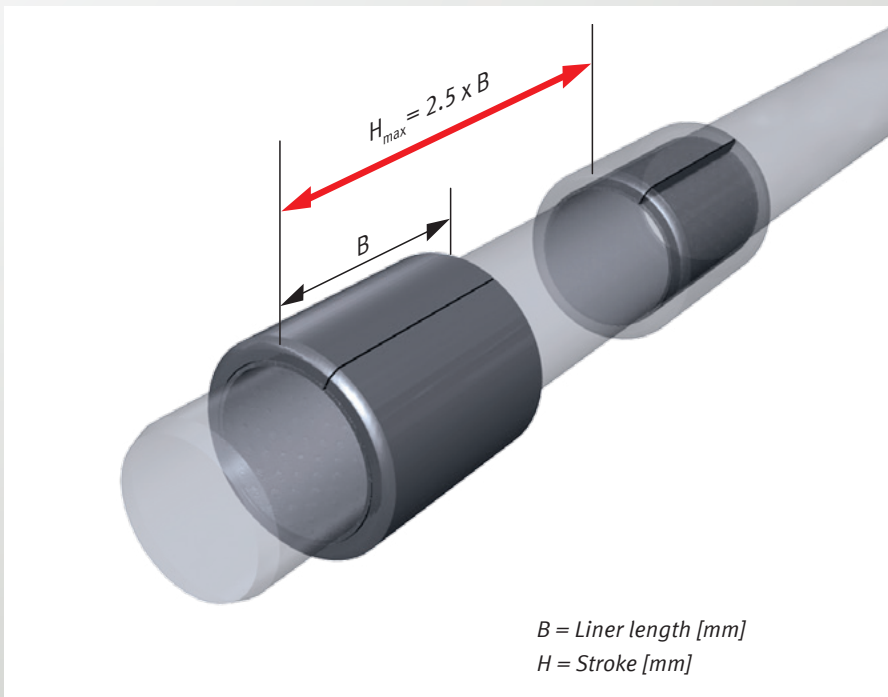

Fig. 33: Linear movement, stroke H_{max} .

Correction factor interacting sliding part material

Material of interacting sliding surface	f_w
Steel	1
Nitrided steel	1
Corrosion-resistant steel	2
Hard chrome-plated steel (min. layer thickness 0.013 mm)	2
Galvanised steel (min. layer thickness 0.013 mm)	0.2
Phosphated steel (min. layer thickness 0.013 mm)	0.2
Grey cast iron R _z 2	1
Anodised aluminium	0.4
Hard anodised aluminium (hardness 450 +50 HV; 0.025 mm thick)	2
Copper-based alloys	0.1 to 0.4
Nickel	0.2

Tab. 24: Correction factor material f_w (with roughness depth R_z 0.8 to R_z 1.5)

[11] Calculating the correction factor linear movement f_L :

$$f_L = 0.65 \frac{B}{H + B} \quad [1]$$

5 | Nominal service life calculation

Special operating conditions

Special operating conditions can both lengthen and shorten the calculated service life. The impact of such influences can often only be estimated. Tab. 25 shows some typical values based on experience.

Evaluating calculated service life

As already discussed in the section Basics, the calculation of the service life of P1/P2 plain bearings is still subject to uncertainty. It depends on the many influencing factors and their interactions on the one hand, and influences such as corrosion, lubricant ageing, chemical reactions and soiling on the expected service life are also impossible to calculate exactly.



Note:

The calculated service life can therefore only be a rough guide. We recommend verifying the use of KS PERMAGLIDE® plain bearings through field-oriented tests.

Operating conditions	Influence on service life	Reason
Dry running; Sometimes interrupted	Lengthens service life	The bearing position occasionally has time to cool down. This has a positive effect on expected service life.
Alternate dry running, running in water	Shortens service life	Hydrodynamic conditions can only be achieved to a limited extent in water. This and the changeover to dry running increases wear.
Continuous operation in liquid lubricants	Greatly lengthens service life	Here, mixed friction or hydrodynamic conditions predominate. The lubricant conveys the frictional heat out of the contact zone. In the hydrodynamic state, the plain bearing runs practically without wear.
Continuous operation in lubricating grease (materials KS PERMAGLIDE® P1)	Reduces or lengthens service life	Solid additives such as MoS ₂ or ZnS encourage the formation of paste and can shorten service life. Nominal service life can be increased through design measures (bore/grooves in the run-out zone) and through regular relubrication (section 6, "Lubrication").

Tab. 25: Special operating conditions

In addition to the wear factors of bearing stress, sliding speed, temperature, shaft material and shaft surface, plain bearings are subject to further stresses arising from the operating conditions, which may have considerable impact on reliability and service life.

Tribochemical reaction, corrosion

KS PERMAGLIDE® plain bearings are basically resistant to water (except P14), alcohol, glycol and many mineral oils. However, some media have an aggressive effect on the composite, particularly the bronze parts. This risk mainly comes into play at operating temperatures in excess of 100 °C. This can have adverse effects on function.

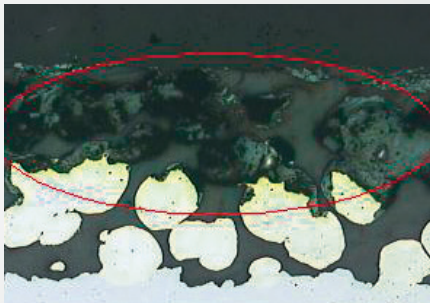

Fig. 34: Damage due to the action of chemicals

The P1 material group is not resistant to acidic media (PH < 3) and alkaline media (pH > 12).

Oxidising acids and gases such as free halides, ammonia or hydrogen sulphide damage the bronze back of P11.

If corrosion would pose a risk to the sliding surface of the interacting sliding part (shaft), the following materials are recommended:

- Corrosion-resistant steel
- Hard chrome-plated steel
- Hard anodised aluminium

These corrosion-resistant materials also lower the wear rate.

Tendency to swell

In the P1 material group, the running-in layer (solid lubricant) can swell in the presence of certain media and at operating temperatures > 100 °C. Depending on the medium, the wall thickness of the plain bearing may increase by up to 0.03 mm.

Remedy:

- Increase bearing clearance
- Use plain bearings made of P14/P147. Here, the tendency to swell is much lower, at < 0.01 mm.

Please note that P14 should only be used at sliding speeds of up to 1 m/s and P147 up to sliding speeds of 0.8 m/s.

Electrochemical contact corrosion

Local elements may form under unfavourable conditions, reducing operational reliability.

Remedy:

Select appropriate material combination

Micro sliding movements

If very small sliding distances take place during swivelling or linear movements, a film of lubricant is unable to form on P1 bearings. Consequently, after the run-in, metal contact zones are produced between the bronze sliding layer and the surface of the shaft.

This results in increased wear, with a risk of shaft seizure.

Remedy:

Lubricate the bearing position. Please note the following section, "Lubrication".

Lubrication

In certain applications, it may be necessary to provide grease or oil lubrication for the contact surface between the P1 plain bearing and the interacting sliding part. This may result in considerable deviations from the expected service life.

The use of grease or oil can both lengthen and shorten service life.

(Tab.. 25: Special operating conditions).

Firstly, service life is shortened by the transfer of solid lubricant during the run-in.

Secondly, the presence of grease or oil gives rise to the formation of a so-called paste.

This paste consists of an accumulation of grease or smaller quantities of oil together with material removed from the contact zone.

This paste deposits itself on the run-out zone in the direction of rotation, hampering the dissipation of heat.

Some of the paste is carried back into the contact zone, where it encourages wear.

Solid lubricants with zinc sulphide or molybdenum disulphide additives increase the tendency towards paste formation.

In cases where lubrication of P1 plain bearings with grease cannot be avoided, the following steps can be taken to counter paste formation:

- Regular relubrication (e.g. with lithium-soap grease)
- Insert bores or grooves in the run-out zone, so that the paste can deposit itself there.

Attention:

Bores or grooves reduce the cross sectional area of the bush wall. If they amount to >10%, this must be taken into account in the calculation (reliable fit, pressfit).

P2 plain bearings must be lubricated. For suitable grease types, see section 3.2 "Low-maintenance KS PERMAGLIDE® P2 plain bearings", "Grease lubrication".

6 | Typical plain bearing damage

Cavitation, erosion

KS PERMAGLIDE® plain bearings can run in hydrodynamic conditions.

Advantage:

- Higher sliding speeds are possible than with dry running or grease lubrication.
- Virtually wear-free operation, as above the transition speed the two sliding surfaces are separated by the lubricating fluid. Conditions of pure liquid friction prevail.
- Plain bearings have a self-lubricating effect during mixed friction (below transition speed).

Despite this, the sliding surface of the plain bearing can suffer particular damage under hydrodynamic conditions, caused above all by cavitation and erosion.

Cavitation and erosion mostly occur simultaneously. These damage symptoms are particularly evident at a high sliding speed.

Remedy:

- Lower the sliding speed (if possible)
- Use a different lubricant (viscosity, load carrying capacity in relation to temperature)
- Avoid flow disruptions in the lubricating gap provoked by oil grooves, oil bores, oil pockets, etc.).

Motorservice offers the calculation of hydrodynamically operated KS PERMAGLIDE® plain bearings as a service.

Cavitation damage

Cavitation damage is local destruction of the sliding surface due to pressure. In plain bearings that run hydrodynamically, vapour bubbles may be produced in the fast moving lubricating film as the result of a drop in pressure. When pressure increases in the fluid, the vapour bubbles break down. The released energy aggressively attacks the sliding surface and hollows out the sliding material in places.



Fig. 35: Local damage caused by cavitation

Erosion damage

Erosion is mechanical damage to the sliding surface due to the rinsing action of a liquid, which may also contain solid particles. The distribution of pressure in the lubricating film of a hydrodynamic bearing assembly is disturbed by turbulence and narrowing of the cross section, resulting in mechanical damage to the sliding surface.

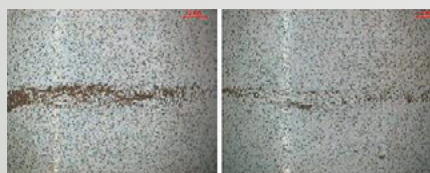

Fig. 36: Damage due to erosion in the running-in layer of a P1 plain bearing

Damaged caused by dirt

If dirt particles enter the contact zone between the bearing and the shaft, the sliding surface of the bearing is damaged by abrasion with scoring. This has negative effects on service life and operational safety.

Remedy:

- Seal the bearing
- Place a filter upstream if using liquid lubrication

Damage due to installation errors

The sliding surface may be damaged when the plain bearing bush is being press fit. In addition, seizures frequently occur between the surface of the bearing jacket and the housing bore. This leads to local bulges in the sliding surface of the bearing. Both the above types of damage can considerably shorten service life.

Remedy:

- Force-fitting device with pre-centring (auxiliary ring)
- Optimised pressfit between housing bore and bearing outside diameter
- Avoid dirt
- Make sure bush is not inclined when force-fitting
- Use suitable lubricant



Fig. 37: P2 plain bearing, grooves in the sliding surface

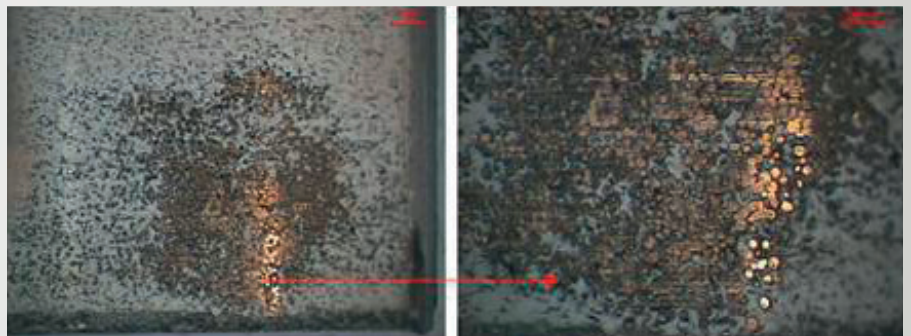

Fig. 38: Local extreme wear due to installation errors

7 | Design and layout of bearing position

7.1 Housing

Bushes

KS PERMAGLIDE® bushes are pressed into the housing and fixed radially and axially. No further measures are required.

For the housing bore, we recommend:

- Roughness depth R_z10
- Chamfer f_G $20^\circ \pm 5^\circ$

This chamfer facilitates force-fitting.

Bore diameter d_G	Chamfer width f_G
$d_G \leq 30$	0.8 ± 0.3
$30 < d_G \leq 80$	1.2 ± 0.4
$80 < d_G \leq 180$	1.8 ± 0.8
$180 < d_G$	2.5 ± 1.0

Tab. 26: Chamfer width f_G in the housing bore for bushes (Fig. 38)

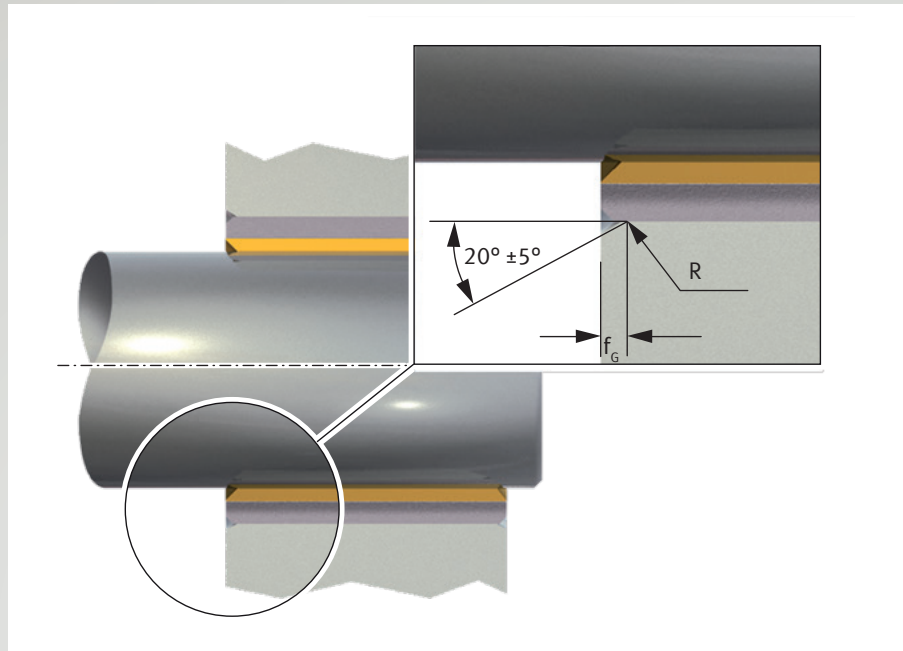

Fig. 39: Chamfer in housing for PAP bush

Flange bushes

In the case of flange bushes, the radius on the transition from the radial to the axial part must be borne in mind.

- Flange bushes must not be in contact in the radius area.
- The flange must have sufficient support when under axial loads.

Bore diameter d_G	Chamfer width f_G
$d_G \leq 10$	1.2 ± 0.2
$10 < d_G$	1.7 ± 0.2

Tab. 27: Chamfer width f_G in the housing bore for flange bushes (Fig. 40)

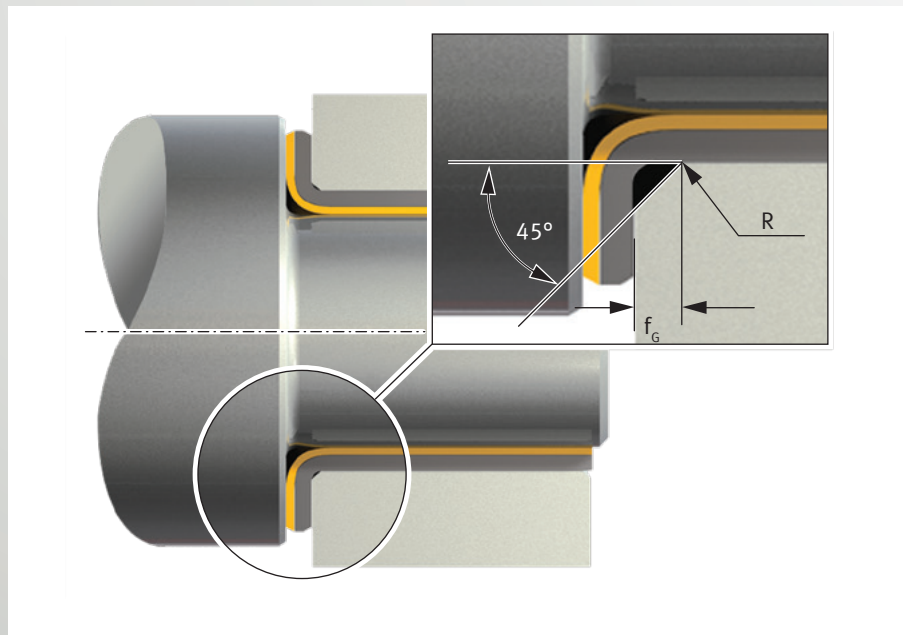

Fig. 40: Chamfer in housing for PAF bush

Securing thrust washers

Recommendation:

- A concentric fit is ensured by the recess in the housing (Fig. 41)
 - See table of dimensions for the diameter and depth of free cuts (section 9)

- Unwanted rotation with the shaft is prevented by means of a register pin or countersunk screw (Figs. 41 and 42)
 - The screw head or register pin must be recessed by min. 0.25 mm from the sliding surface (Figs. 41 and 42)
 - See table of dimensions for size and position of bores (section 9).
- If no recess can be made in the housing:
 - Secure with several register pins or screws (Fig. 42).
 - Use other methods for fastening.

Rotation prevention is not always required. In various cases, the static friction between the back of the washer and the housing is sufficient.

Other fastening methods

If the press fit of the bush is insufficient or pinning or screwing is uneconomical, low-cost fastening methods can be used as an alternative:

- Laser welding
- Soft-soldering
- Gluing; please see the note below

⚠ Attention: The temperature of the running-in or sliding layer must not exceed +280 °C for the KS PERMAGLIDE® P1 and +140 °C for KS PERMAGLIDE® P2. Adhesive must not reach the running-in or sliding layer. Recommendation: Obtain information on gluing from adhesive manufacturers, particularly concerning the choice of adhesive, preparing the surface, setting, strength, temperature range and strain characteristics.

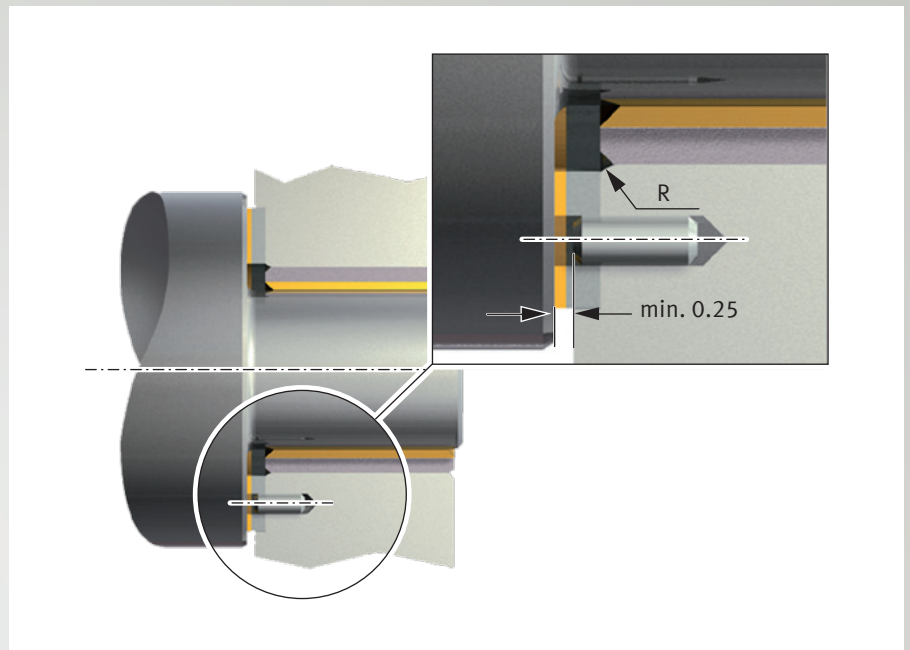

Fig. 41: Attaching a PAW thrust washer in a recess in the housing

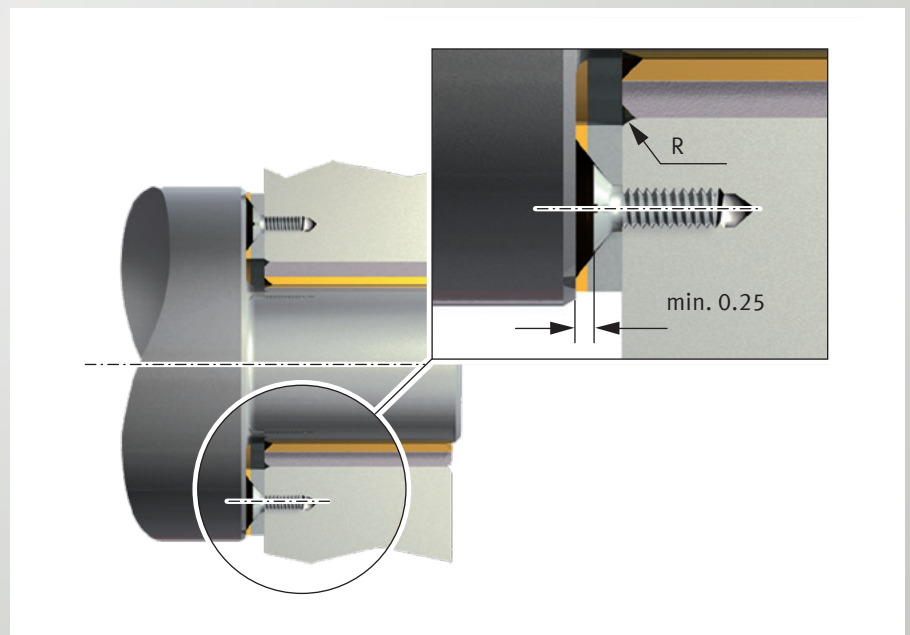

Fig. 42: Attaching a PAW thrust washer without a recess in the housing

7.2 Design of the interacting sliding part

The following generally applies:

In a tribological system, the shaft (in the case of radial bearings) or the pressure shoulder (in the case of thrust bearings) should project over the sliding surface to maximise the contact ratio and prevent running-in with deposits in the sliding layer.

Shaft

Shafts must be chamfered and all sharp edges rounded, which:

- Simplifies mounting
- Prevents damage to the bush sliding layer

Shafts must never have grooves or pricks in the area of the sliding zone.

Interacting sliding surface

Optimum service life thanks to correct roughness depth

- Optimum service life is achieved when the interacting sliding surface has a roughness depth of $R_z 0.8$ to $R_z 1.5$:
 - with dry-running KS PERMAGLIDE® P1
 - with lubrication on KS PERMAGLIDE® P2.



Attention:

Smaller roughness depths do not prolong the service life and may even cause adhesive wear. Larger roughness depths are significantly reduced.

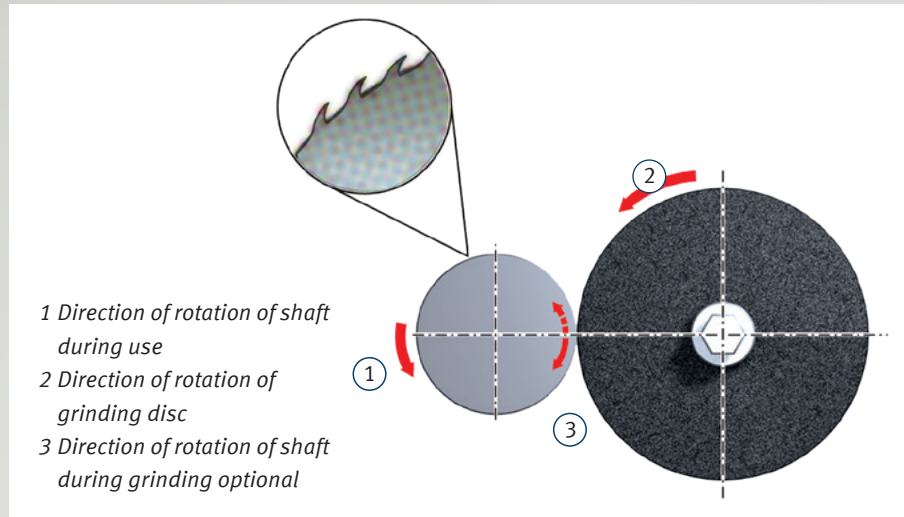

Fig. 43: Grinding a cast shaft

- With KS PERMAGLIDE® P1 and P2, corrosion on the interacting sliding surface is prevented by:
 - sealing,
 - use of corrosion-resistant steel,
 - suitable surface treatment.

With KS PERMAGLIDE® P2, the lubricant is also effective against corrosion.

Surface quality

- Ground or drawn surfaces are preferable
- Precision-turned or precision-turned and roller burnished surfaces, even with $R_z 0.8$ to $R_z 1.5$, can cause greater wear (precision turning produces spiral scores)

- Spheroidal graphite iron (GGG) has an open surface structure, and should therefore be ground to $R_z 2$ or better. Fig. 43 shows the direction of rotation of cast shafts in use. This should be the same as the direction of rotation of the grinding disc, as more wear will occur in the opposite direction.

Hydrodynamic operation

For hydrodynamic operation, the roughness depth R_z of the interacting sliding surface should be less than the smallest lubricating film thickness.

Motorservice offers hydrodynamic calculation as a service.

Gaskets

Protecting the bearing position is recommended in the event of greater exposure to dirt or in the case of an aggressive environment.

Fig. 44 shows recommended gasket types:

- The surrounding gasket (1)
- A gap gasket (2)
- A shaft seal (3)
- A ring of grease

Heat dissipation

Thorough heat dissipation must be assured.

- In hydrodynamic operation, heat is mainly conveyed away by the lubricating liquid.
- In dry and grease-lubricated plain bearings, the heat is also dissipated by the housing and shaft.

Machining the bearing elements

- KS PERMAGLIDE® plain bearings can be cut or can be machined in other ways (e.g. shortening, bending or boring)
- KS PERMAGLIDE® plain bearings should preferably be cut from the PTFE side. The burrs produced during cutting would impair the sliding surface.
- Bearing elements must be cleaned after machining.
- Bare steel surfaces (cut edges) must be protected against corrosion with:
 - Oil, or
 - Galvanic protective layers

At higher flow densities or with longer coating times, the sliding layers must be covered to prevent deposits.

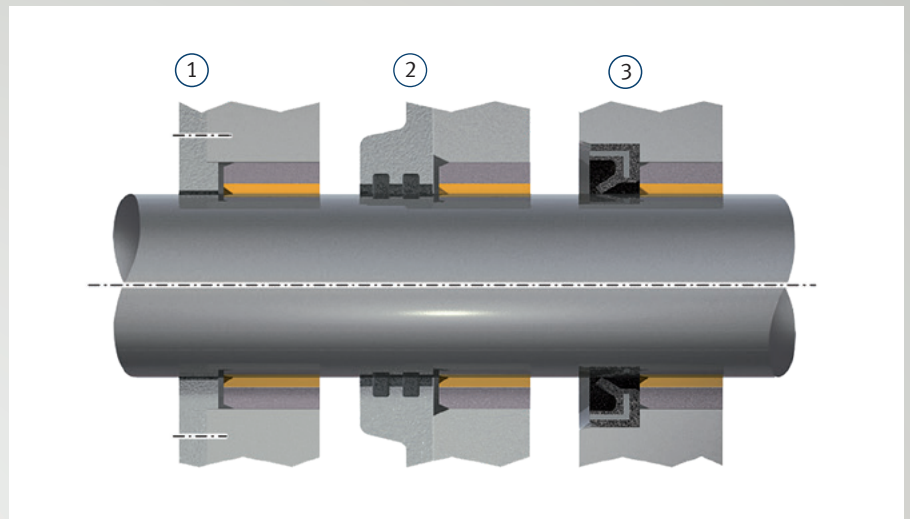

Fig. 44: Gaskets



Attention:

Machining temperatures that exceed the following limits are hazardous to health:

+280 °C for KS PERMAGLIDE® P1

+140 °C for KS PERMAGLIDE® P2

Chips may contain lead.

7 | Design and layout of bearing position

Axial orientation (precise alignment)

Precise alignment is important for all radial and axial plain bearings. This is particularly the case for dry-running plain bearings, in which the load cannot be distributed via the lubricating film.

Misalignment over the entire liner length must not exceed 0.02 mm (Fig. 45). This figure also applies to the overall width of bushes arranged in pairs, and of thrust washers.

Bushes arranged one behind the other may need to have the same width. The joints must be flush during mounting.

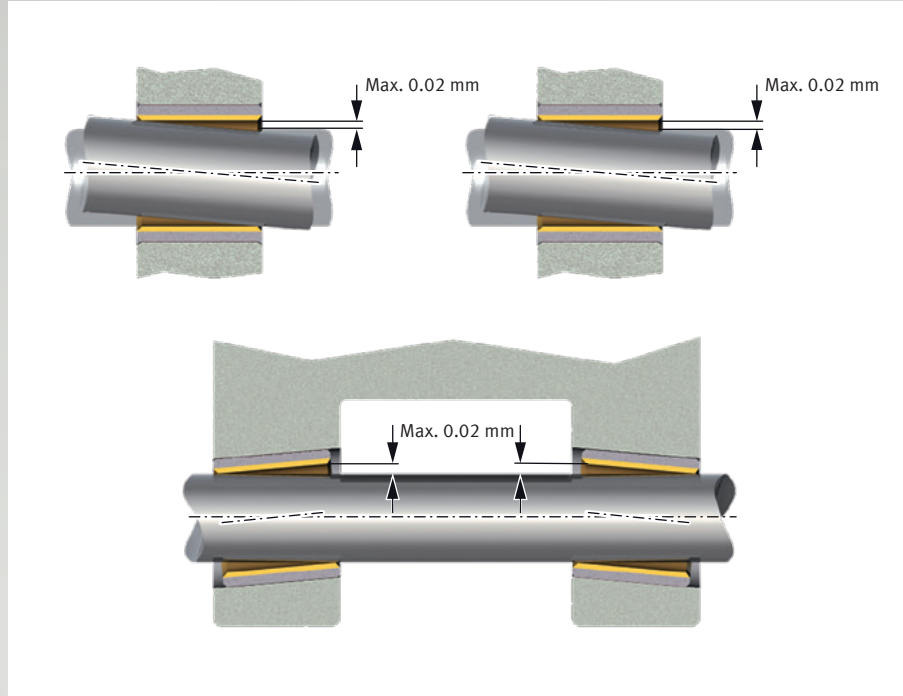

Fig. 45: Permitted misalignment

Edge load on the installed plain bearing

Excessively high stresses around the edges of the plain bearing may occur as the result of geometric inaccuracies or under special operating conditions. This type of "high edge loading" can cause the bearing to become jammed. This stress can be reduced through design measures (Fig. 46).

- Enlarged chamfers on housing
- Enlarged bore diameter in edge region of housing bore
- Allow liner length to project beyond width of housing.

In addition, edge loading can be relieved by housing with an elastic design.

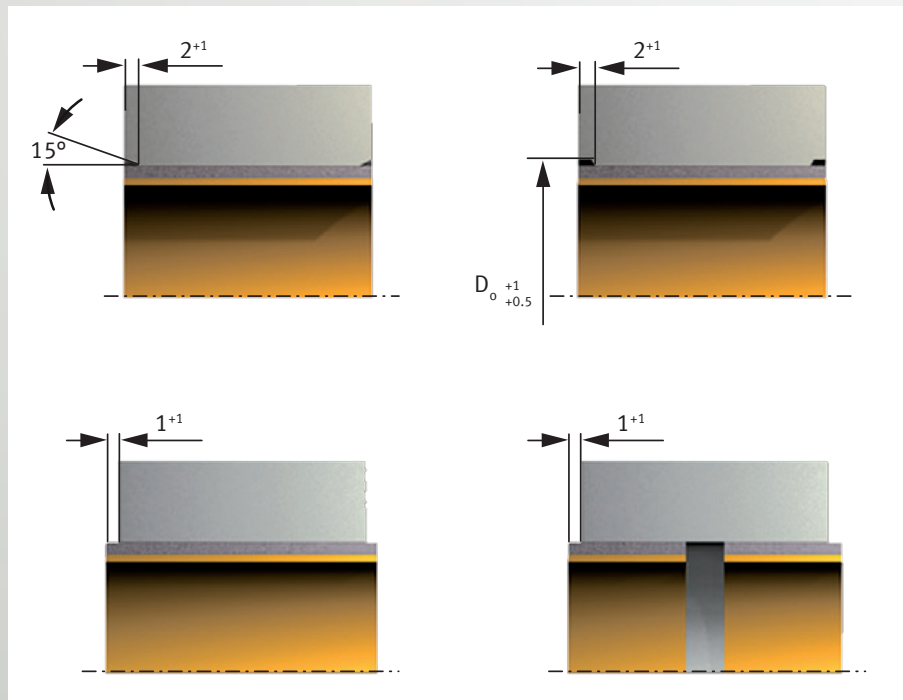

Fig. 46: Reducing peak stresses on edges

7.3 Bearing clearance, press fit

Theoretical bearing clearance

Bushes made from KS PERMAGLIDE® P1 and P2 are pressed into the housing and fixed in place radially and axially.

No further measures are required. With the fitting tolerances from Tab. 28, the following applies for rigid housing and shafts:

- The press fit
- The bearing clearance in accordance with Tab. 33

The theoretical bearing clearance is calculated as follows:

$$[12] \quad \Delta s_{\max} = d_{G\max} - 2 \cdot s_{3\min} - d_{W\min}$$

$$[13] \quad \Delta s_{\min} = d_{G\min} - 2 \cdot s_{3\max} - d_{W\max}$$

Δs_{\max}	[mm]	Maximum bearing clearance
Δs_{\min}	[mm]	Minimum bearing clearance
$d_{G\max}$	[mm]	Maximum diameter of housing bore
$d_{G\min}$	[mm]	Minimum diameter of housing bore
$d_{W\max}$	[mm]	Maximum shaft diameter
$d_{W\min}$	[mm]	Minimum shaft diameter
$s_{3\max}$	[mm]	Maximum wall thickness
$s_{3\min}$	[mm]	Minimum wall thickness (Tab. 32)

Attention: Widening the housing bore is not taken into consideration in the bearing clearance calculation.

For calculating the pressfit U, the tolerances of the housing bore are shown in Tab. 28 and the bush outside diameter D_o in Tab. 29.

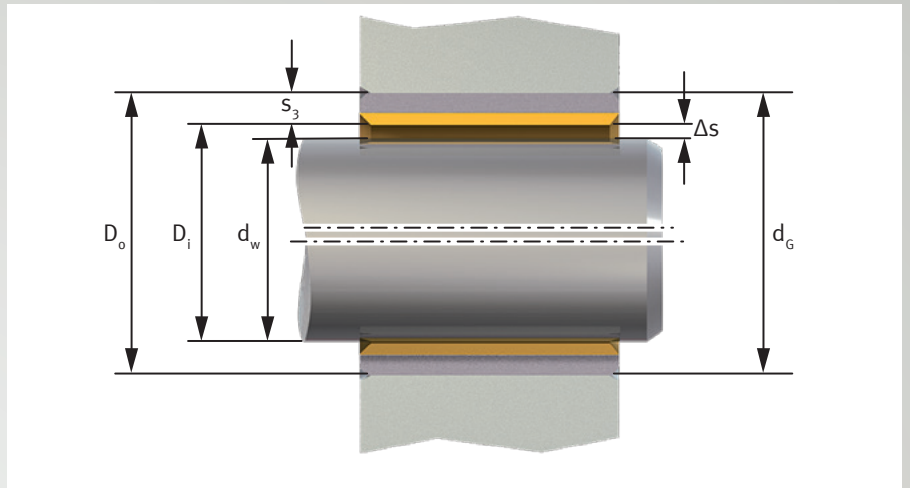

Fig. 47: Theoretical bearing clearance Δs

Press fit and bearing clearance

The bearing clearance and press fit can be influenced by the measures shown in Tab. 35:

- At high ambient temperatures
- Depending on the housing material
- Depending on the housing wall thickness

Smaller clearance tolerances require narrower tolerances for the shaft and bore.

Attention: When using shafts with tolerance zone position h, the bearing clearance for $5 \leq d_w < 80$ (P10, P14, P147) and $d_w < 80$ (P11) must be verified using equations [12] for Δs_{\max} and [13] for Δs_{\min} .

Diameter range	KS PERMAGLIDE®		
	P10, P14, P147*	P11	P20, P200
Shaft			
$d_w < 5$	h6	f7	h8
$5 \leq d_w < 80$	f7	f7	h8
$80 \leq d_w$	h8	h8	h8
Housing bore			
$d_g \leq 5.5$	H6	–	–
$5.5 < d_g$	H7	H7	H7

Tab. 28: Recommended fitting tolerances

* On request

7 | Design and layout of bearing position

Outside diameter of bush D_o			Dimensions (test A to DIN ISO 3547-2)			
			P10, P14, P147*, P20, P200		P11	
			Upper	Lower	Upper	Lower
	$D_o \leq$	10	+0.055	+0.025	+0.075	+0.045
10	$< D_o \leq$	18	+0.065	+0.030	+0.080	+0.050
18	$< D_o \leq$	30	+0.075	+0.035	+0.095	+0.055
30	$< D_o \leq$	50	+0.085	+0.045	+0.110	+0.065
50	$< D_o \leq$	80	+0.100	+0.055	+0.125	+0.075
80	$< D_o \leq$	120	+0.120	+0.070	+0.140	+0.090
120	$< D_o \leq$	180	+0.170	+0.100	+0.190	+0.120
180	$< D_o \leq$	250	+0.210	+0.130	+0.230	+0.150
250	$< D_o \leq$	305	+0.260	+0.170	+0.280	+0.190

Tab. 29: Dimensions for outside diameter D_o .

Inside diameter of bush D_i			Wall thickness s_3	Dimensions as per DIN ISO 3547-1, Table 3, Row B			
				P10, P14, P147*		P11	
				Upper	Lower	Upper	Lower
	$D_i <$	5	0.75	0	-0.020	-	-
			1	-	-	+0.005	-0.020
5	$\leq D_i <$	20	1	+0.005	-0.020	+0.005	-0.020
20	$\leq D_i <$	28	1.5	+0.005	-0.025	+0.005	-0.025
28	$\leq D_i <$	45	2	+0.005	-0.030	+0.005	-0.030
45	$\leq D_i <$	80	2.5	+0.005	-0.040	+0.005	-0.040
80	$\leq D_i <$	120	2.5	-0.010	-0.060	-0.010	-0.060
120	$\leq D_i$		2.5	-0.035	-0.085	-0.035	-0.085

Tab. 30: Wall thickness s_3 for P1 bushes and flange bushes

Surface roughness	Ra (μm)	Rz (μm)
Bearing bore D_i	6.3	25.0
Bearing back D_o	1.6	6.3
Other surfaces	25.0	100.0

Tab. 31: Surface roughness, roughness depth R_a and R_z

Inside diameter			Wall thickness s_3	Dimensions as per DIN ISO 3547-1, Table 3, Row D, P20, P200	
D_i				Upper	Lower
8	$\leq D_i <$	20	1	-0.020	-0.045
20	$\leq D_i <$	28	1.5	-0.025	-0.055
28	$\leq D_i <$	45	2	-0.030	-0.065
45	$\leq D_i <$	80	2.5	-0.040	-0.085
80	$\leq D_i$		2.5	-0.050	-0.115

Tab. 32: Wall thickness s_3 for bushes made from KS PERMAGLIDE® P20/P200

Wall thickness s_3	Outside bevel, without cutting C_o	Inside bevel C_i	
		Min.	max.
0.75	0.5 ± 0.3	0.1	0.4
1	0.6 ± 0.4	0.1	0.6
1.5	0.6 ± 0.4	0.1	0.7
2	1.0 ± 0.4	0.1	0.7
2.5	1.2 ± 0.4	0.2	1.0

Tab. 33: Outside bevel C_o and inside bevel C_i (Fig. 48) for bushes with metric dimensions to DIN ISO 3547-1, Table 2

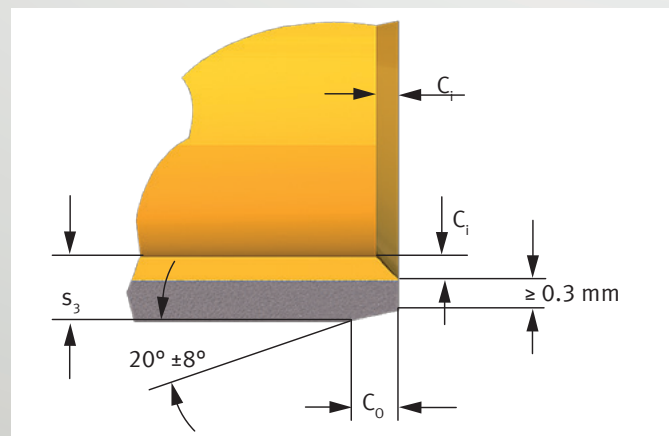

Fig. 48: Outside bevel C_o and inside bevel C_i with metric dimensions

* On request

Theoretical bearing clearance

Bush diameter		Bearing clearance Δs			
		P10, P11, P14, P147*		P20, P200	
D_i (mm)	D_o (mm)	Δs_{min} (mm)	Δs_{max} (mm)	Δs_{min} (mm)	Δs_{max} (mm)
2	3.5	0	0.054	–	–
3	4.5	0	0.054	–	–
4	5.5	0	0.056	–	–
5	7	0	0.077	–	–
6	8	0	0.077	–	–
7	9	0.003	0.083	–	–
8	10	0.003	0.083	0.040	0.127
10	12	0.003	0.086	0.040	0.130
12	14	0.006	0.092	0.040	0.135
13	15	0.006	0.092	–	–
14	16	0.006	0.092	0.040	0.135
15	17	0.006	0.092	0.040	0.135
16	18	0.006	0.092	0.040	0.135
18	20	0.006	0.095	0.040	0.138
20	23	0.010	0.112	0.050	0.164
22	25	0.010	0.112	0.050	0.164
24	27	0.010	0.112	0.050	0.164
25	28	0.010	0.112	0.050	0.164
28	32	0.010	0.126	0.060	0.188
30	34	0.010	0.126	0.060	0.188
32	36	0.015	0.135	0.060	0.194
35	39	0.015	0.135	0.060	0.194
40	44	0.015	0.135	0.060	0.194
45	50	0.015	0.155	0.080	0.234
50	55	0.015	0.160	0.080	0.239
55	60	0.020	0.170	0.080	0.246
60	65	0.020	0.170	0.080	0.246
65	70	0.020	0.170	–	–
70	75	0.020	0.170	0.080	0.246
75	80	0.020	0.170	0.080	0.246
80	85	0.020	0.201	0.100	0.311
85	90	0.020	0.209	–	–
90	95	0.020	0.209	0.100	0.319
95	100	0.020	0.209	–	–
100	105	0.020	0.209	0.100	0.319
105	110	0.020	0.209	–	–

Bush diameter		Bearing clearance Δs			
		P10, P11, P14, P147*		P20, P200	
D_i (mm)	D_o (mm)	Δs_{min} (mm)	Δs_{max} (mm)	Δs_{min} (mm)	Δs_{max} (mm)
110	115	0.020	0.209	–	–
115	120	0.020	0.209	–	–
120	125	0.070	0.264	–	–
125	130	0.070	0.273	–	–
130	135	0.070	0.273	–	–
135	140	0.070	0.273	–	–
140	145	0.070	0.273	–	–
150	155	0.070	0.273	–	–
160	165	0.070	0.273	–	–
180	185	0.070	0.279	–	–
200	205	0.070	0.288	–	–
220	225	0.070	0.288	–	–
250	255	0.070	0.294	–	–
300	305	0.070	0.303	–	–

Tab. 34: Theoretical bearing clearance after press-fitting bushes or flange bushes with metric dimensions, without consideration of possible widening of the bore

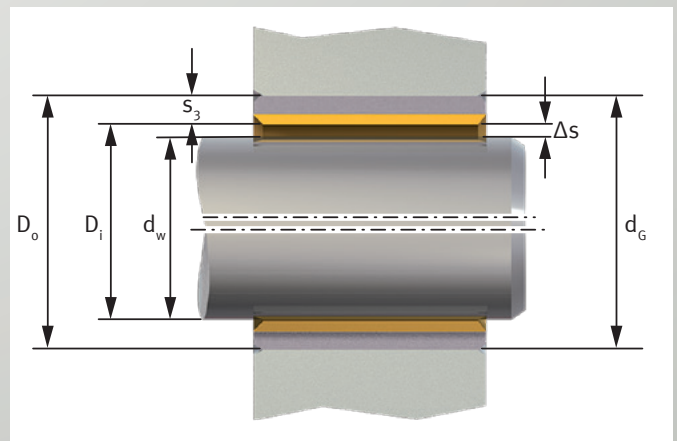

Fig. 49: Theoretical bearing clearance Δs

* On request

7 | Design and layout of bearing position

Press fit and bearing clearance

Design and environmental influences	Consequence	Measure	Note
Aluminium alloy or thin-walled housing	Extensive widening Excessive clearance	Reduce housing bore d_G	The housing is under greater strain; the permitted housing tension must not be exceeded.
Steel or cast iron housing at high ambient temperatures	Smaller clearance	Reduce shaft diameter d_w by 0.008 mm per 100 °C above room temperature	
Bronze or copper alloy housing at high ambient temperatures	Poor press fit	Reduce housing bore d_G , recommended change to diameter per 100 °C above room temperature: $d_G - 0.05\%$	Reduce shaft diameter d_w by the same value, in order to retain the same bearing clearance.
Aluminium alloy housing at high ambient temperatures	Poor press fit	Reduce housing bore d_G , recommended change to diameter per 100 °C above room temperature: $d_G - 0.1\%$	Reduce shaft diameter d_w by the same value, in order to retain the same bearing clearance. The housing is under greater strain at temperatures below 0 °C; the permitted housing tension must not be exceeded.
Bushes with thicker layer of corrosion protection	Outside diameter D_o too large Insufficient clearance	Enlarge housing bore d_G For example: Layer thickness 0.015 ± 0.003 mm producing $d_G + 0.03$ mm	The bush and housing are subject to greater strain unless appropriate measures are taken.

Tab. 35: Errors, consequences and measures in relation to press fit and bearing clearance at high ambient temperatures, with special housing materials or housing wall thicknesses

KS PERMAGLIDE® bushes can simply be pressed into the housing bore. Applying a little oil to the back of the bush or the housing bore facilitates the press-fitting operation.

Recommended press-fitting methods

For outside diameters D_o up to around 55 mm:

- Flush press-fitting with mandrel, without auxiliary ring, as per Fig. 51
- Recessed press-fitting with mandrel, without auxiliary ring, as per Fig. 52.

For outside diameters D_o from around 55 mm:

- Press-fitting with mandrel and auxiliary ring, as per Fig. 53.



Attention:

Ensure cleanliness during mounting. Dirt reduces the service life of the bearing assembly.

Take care not to damage the sliding layer. Note the installation position, if given.

Do not position the joint in the main load zone.

Avoid an inclined position or axis offset

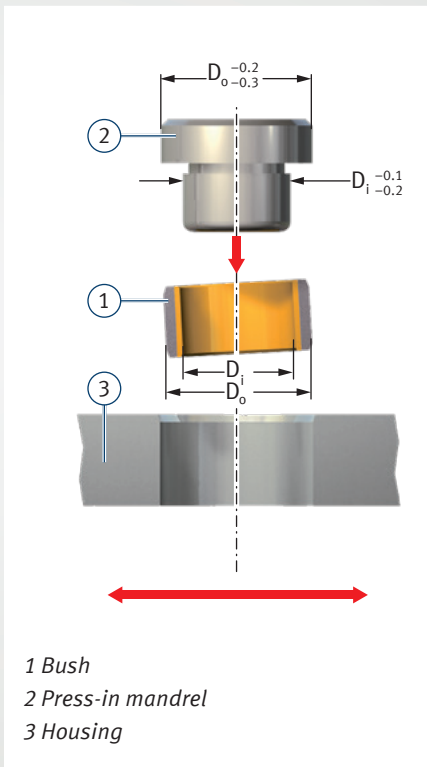

Fig. 50: Press-fitting with moving housing

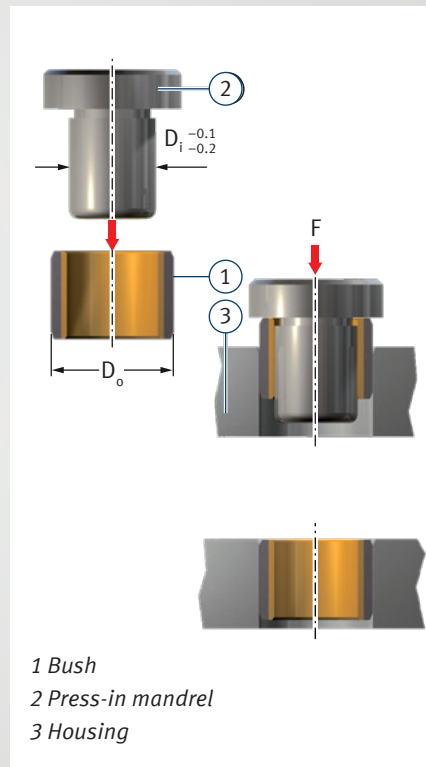

Fig. 51: Flush press-fitting $D_o \leq 55$ mm

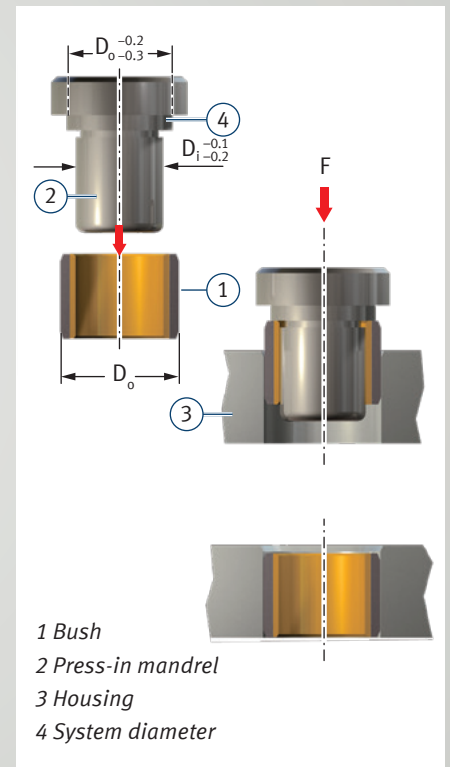

Fig. 52: Recessed press-fitting $D_o \leq 55$ mm

8 | Plain bearing installation

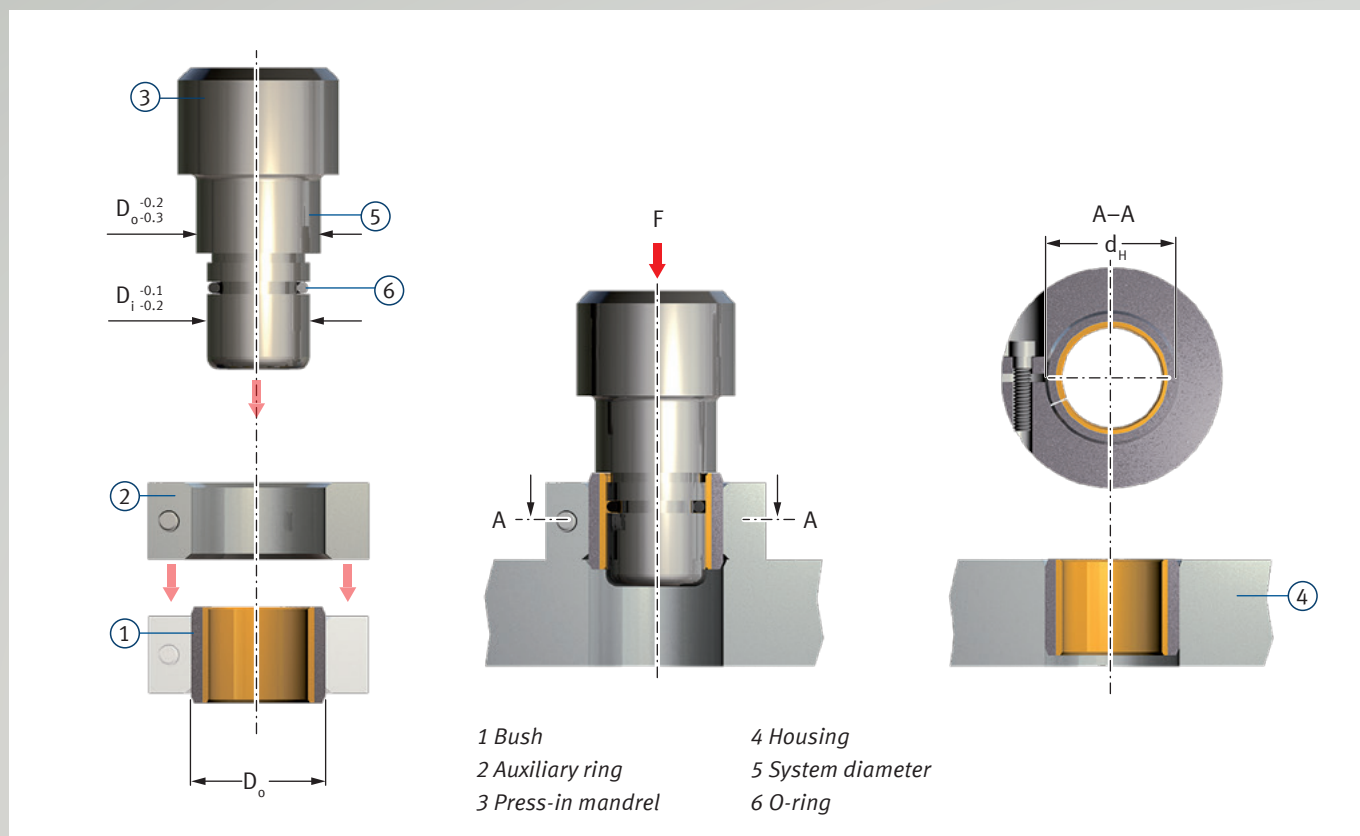

Fig. 53: Press-fitting bushes, $D_o \geq 55$ mm, with auxiliary ring

Tab. 35 allows you to calculate the required inside diameter d_H of the auxiliary ring on the basis of the stated outside diameter D_o of the bush.

D_o (mm)	d_H (mm)	
$55 \leq D_o \leq 100$	D_o	+0.28
		+0.25
$100 < D_o \leq 200$	D_o	+0.40
		+0.36
$200 < D_o \leq 305$	D_o	+0.50
		+0.46

Tab. 36: Inside diameter d_H of auxiliary ring

Calibration of bearing bore after installation (applies to P1 plain bearings only)

Calibration

KS PERMAGLIDE® plain bearings are ready to install on delivery, and should only be calibrated if a bearing clearance with a narrower tolerance cannot otherwise be reached.



Attention:

Calibration considerably shortens the service life of KS PERMAGLIDE® P1 bushes (Tab. 37).

Fig. 53 shows calibration using a mandrel. Tab. 36 contains standard values for the diameter of the calibrating mandrel d_k . Precise values can only be ascertained through tests.

Better possibilities

The bearing clearance tolerance can be reduced through the following measures, which do not adversely affect service life:

- Narrower tolerances for housing bore
- Narrower shaft tolerances.

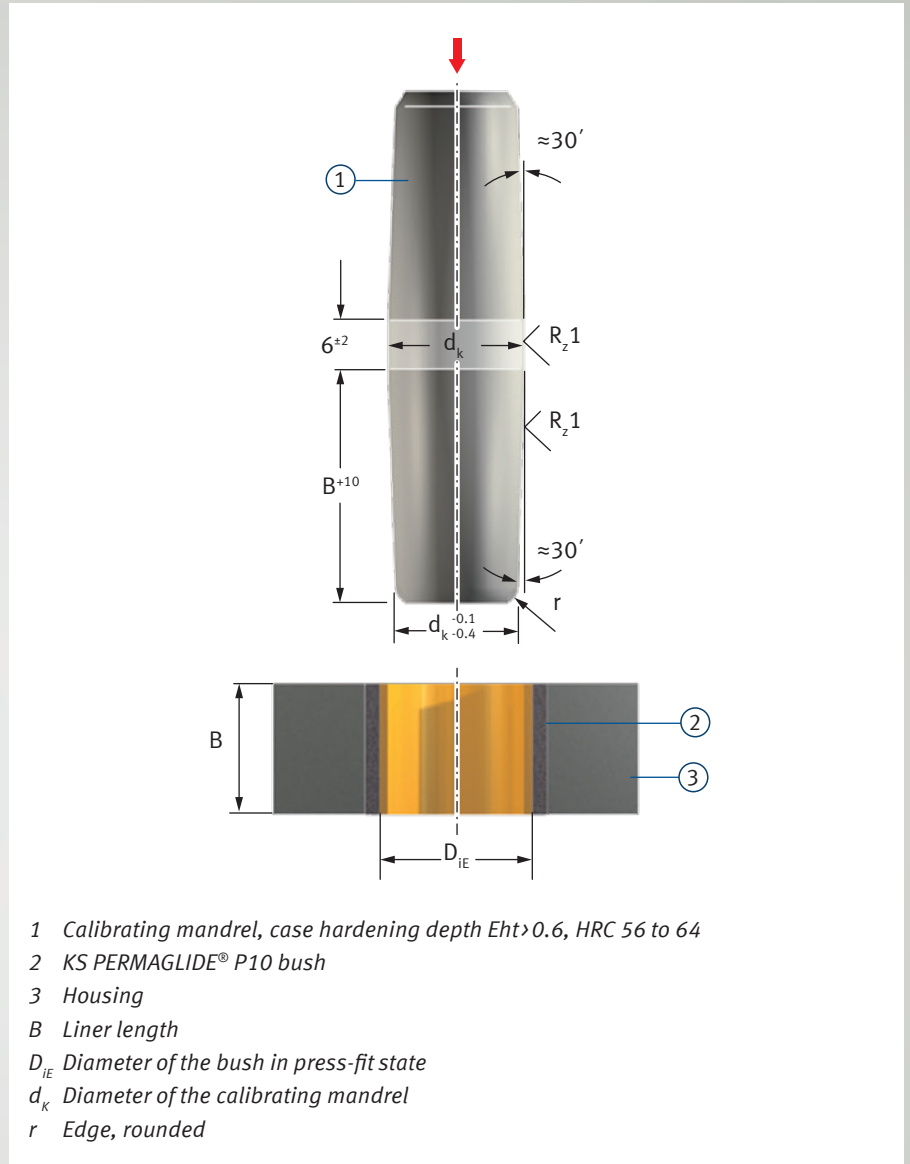

- 1 Calibrating mandrel, case hardening depth $E_{ht} > 0.6$, HRC 56 to 64
 - 2 KS PERMAGLIDE® P10 bush
 - 3 Housing
- B Liner length
 D_{IE} Diameter of the bush in press-fit state
 d_k Diameter of the calibrating mandrel
 r Edge, rounded

Fig. 54: Calibration

Desired inside diameter of the bush	Diameter of calibrating mandrel ¹⁾ d_k	Service life ²⁾
D_{IE}	–	100% L_N
$D_{IE} + 0.02$	$D_{IE} + 0.06$	80% L_N
$D_{IE} + 0.03$	$D_{IE} + 0.08$	60% L_N
$D_{IE} + 0.04$	$D_{IE} + 0.10$	30% L_N

Tab. 37: Standard values for the calibrating mandrel diameter and the reduction in service life

D_{IE} Inside diameter of the bush in press-fit state.

¹⁾ Standard value, based on steel housing.

²⁾ Standard value for dry running.

8 | Plain bearing installation

Press-in force and joint pressure

Press-in force and joint pressure are interdependent. The joint pressure occurs between the housing bore and the surface of the bush jacket. It can be understood as a measure of how reliably the bush fits in the housing. Together with other factors, the joint pressure influences the amount of press-in force.

Calculating the press-in force

The press-in force depends upon many factors, which are extremely difficult to measure accurately, for example:

- Actual press-fit
- Coefficient of friction
- Scoring
- Press-in speed

Motorservice offers the calculation of the press-in force as a service. In most cases, the estimate of press-in force as per Fig. 55 is sufficient.

Determining the bush press-in force

Fig. 55 below shows the maximum required press-in force per mm of liner length. The curves represent the bush outside diameter D_0 and the bush wall thickness s_3 in accordance with DIN ISO 3547. This calculation assumes a steel housing with a diameter of D_6 that has been adapted to the bush outside diameter D_0 . The selected ratio is $D_6 : D_0 \approx 1.5 \dots 2$.

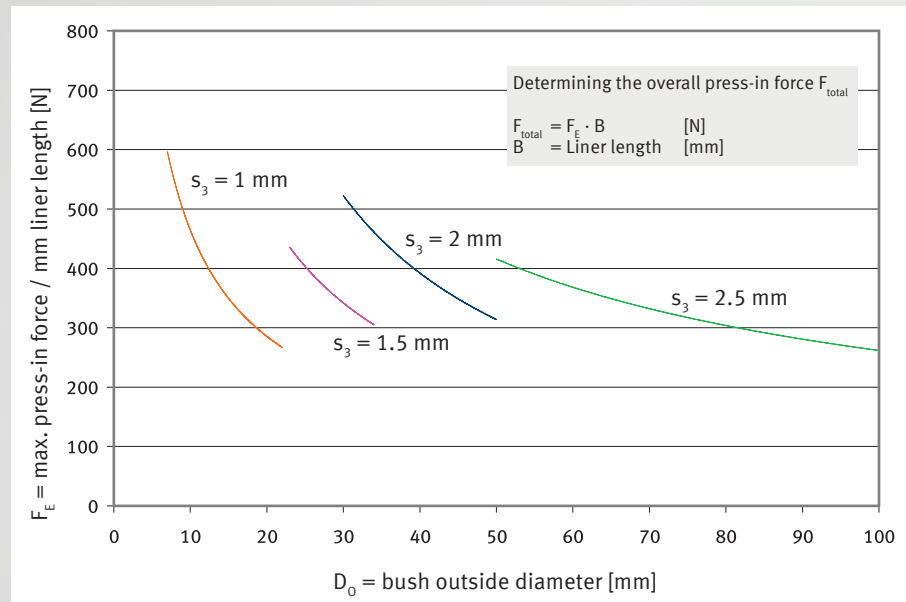

Fig. 55: Press-in force F_E

Example of estimate of press-in force F_{total}

Given:	Bush	PAP 4030 P14
	Bush outside diameter	$D_0 = 44$ mm
	Liner length	$B = 30$ mm
	Bush wall thickness	$s_3 = 2$ mm

$$[14] \quad F_{tot} = F_E \cdot B = 340 \text{ N/mm} \cdot 30 \text{ mm} = 10200 \text{ N}$$

$F_E = 340$ N/mm (from Fig. 55, $D_0 = 44$ mm, $s_3 = 2$ mm)

Bushes



Fig. 56: Bushes

P10, P14, P147*

- For shafts from 2 mm to 300 mm

P11

- For shafts from 4 mm to 100 mm

P20, P22*, P23*, P200, P202*, P203*

- For shafts from 8 mm to 100 mm

Maintenance-free KS PERMAGLIDE® plain bearings P10, P11, P14, P147*

Technical data		P10, P11	P14	P147*
Designation	Unit			
$p_{v \max.}$	[MPa · m/s]	1.8	1.6	1.4
$p_{\text{stat.}}$	[MPa]	250	250	250
$p_{\text{dyn.}}$	[MPa]	56	56	56
$v_{\max.}$	[m/s]	2	1	0.8
T	[°C]	-200 to +280	-200 to +280	-200 to +280

KS PERMAGLIDE® P10 with steel back, KS PERMAGLIDE® P11 with bronze back

Low-maintenance KS PERMAGLIDE® plain bearings P20, P22*, P23*, P200, P202*, P203*

Technical data		P20, P22*, P23*	P200, P202*, P203*
Designation	Unit		
$p_{v \max.}$	[MPa · m/s]	3	3.3
$p_{\text{stat.}}$	[MPa]	250	250
$p_{\text{dyn.}}$	[MPa]	70	70
$v_{\max.}$	[m/s]	3	3.3
T	[°C]	-40 to +110	-40 to +110

Flange bushes

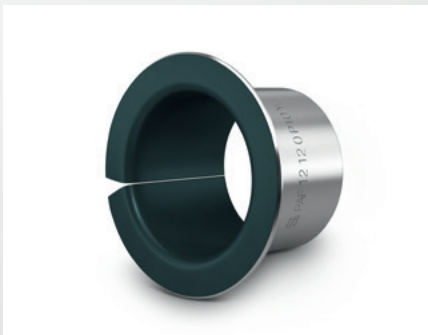

Fig. 57: Flange bushes

P10, P11, P14, P147*

- For shafts from 6 mm to 40 mm

Thrust washers



Fig. 58: Thrust washers

P10, P11, P14, P147*

- With an inside diameter of 10 mm to 62 mm

P20, P22*, P23*, P200, P202*, P203*

- With an inside diameter of 12 mm to 52 mm

Strips

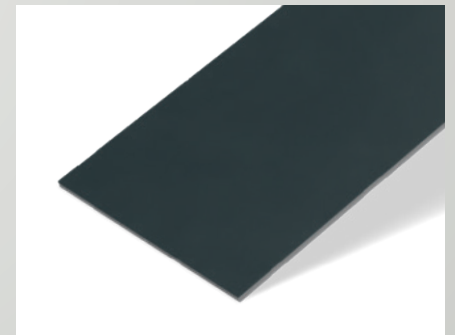

Fig. 59: Strips

P10, P11, P14, P147*

- Length 500 mm
- For widths see tables of dimensions
- For wall thicknesses see tables of dimensions

P20, P22*, P23*, P200, P202*, P203*

- Length 500 mm
- Width 250 mm
- For wall thicknesses see tables of dimensions

* On request

9 | Models and tables of dimensions

Example order and example designation

Bush of KS PERMAGLIDE® P10 with steel back:

Inside diameter (D_i) 16 mm
 Width (B) 25 mm
 Order designation: PAF 1625 P10

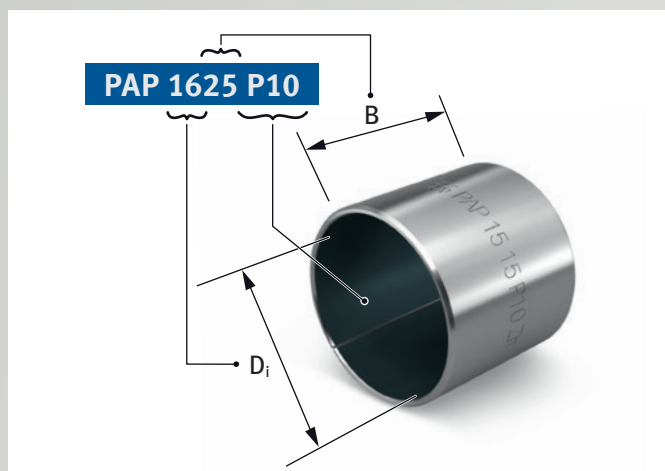

Fig. 60: Example order, P10 bush

Strips of KS PERMAGLIDE® P20:

Width (B) 180 mm
 Wall thickness (s_3) 1 mm
 (Order information: $s_3 \cdot 10$)
 Order designation: PAS 10180 P20

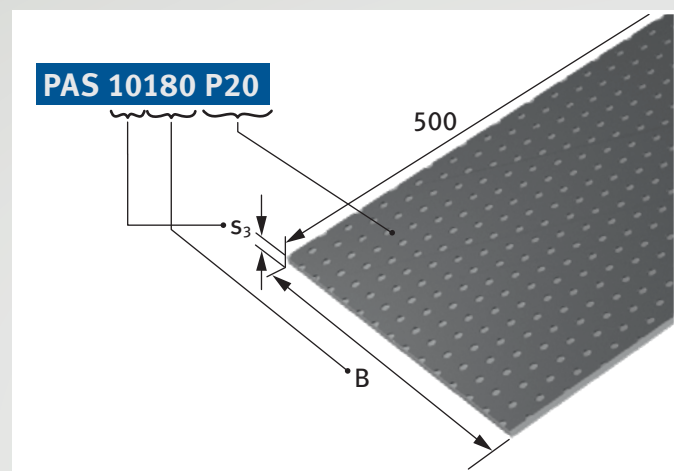

Fig. 61: Example order, P20 strip

Flange bush of KS PERMAGLIDE® P10:

Inside diameter (D_i) 25 mm
 Width (B) 21.5 mm
 Order designation: PAF 25215 P10

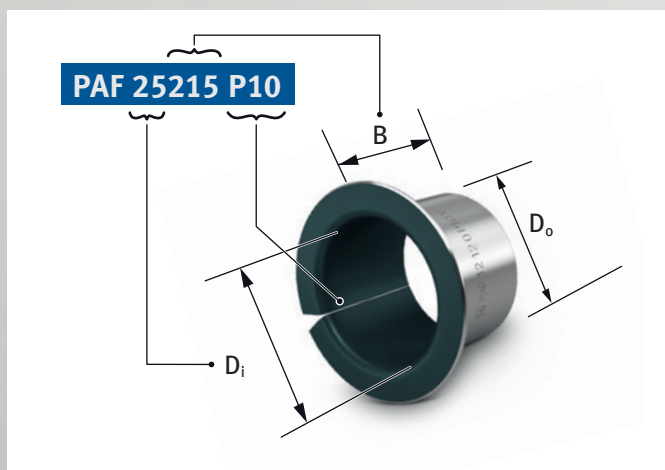

Fig. 62: Example order, flange bush P10

Thrust washers of KS PERMAGLIDE® P20:

Inside diameter (D_i) 12 mm
 Order designation: PAW 12 P20

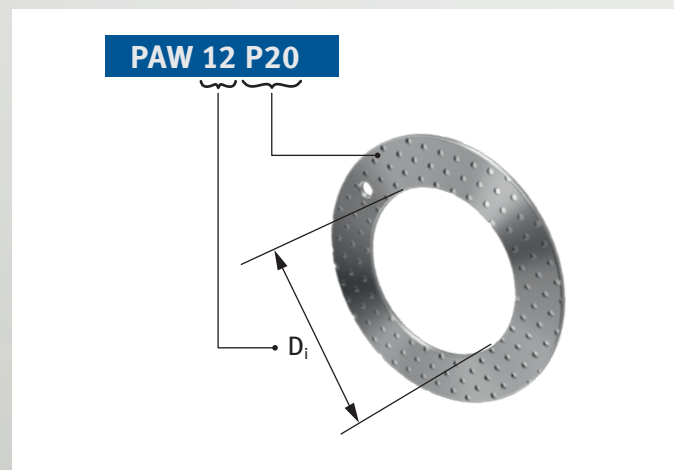

Fig. 63: Example order, P20 thrust washer

9.1 KS PERMAGLIDE® bushes, maintenance-free

9.1.1 Model range P10, P14, P147* with steel back

Recommended fitting tolerance:

Shaft		Housing bore	
$d_w < 5$	h6	$d_G \leq 5.5$	H6
$5 \leq d_w < 80$	f7	$5.5 < d_G$	H7
$80 \leq d_w$	h8		

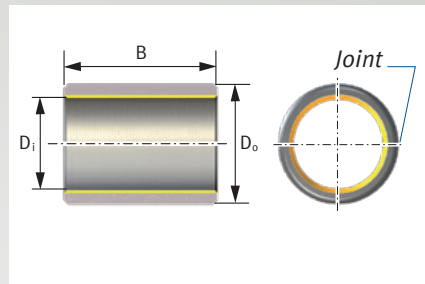

For bearing clearances, wall thicknesses and chamfer tolerances, see section 7, "Design and layout of bearing position", "Theoretical bearing clearance".
Bushes in special dimensions available on request (section 9.8).

Table of dimensions (dimensions in mm)					
Shaft diameter	Order designation P10, P14, P147*	Earth g	Dimensions		
			D _i	D _o	B ±0.25
2	PAP 0203 ... P10/... P14/... P147*	0.15	2	3.5	3
	PAP 0205 ... P10/... P14*/... P147*	0.25	2	3.5	5
3	PAP 0303 ... P10/... P14/... P147*	0.2	3	4.5	3
	PAP 0304 ... P10/... P14/... P147*	0.26	3	4.5	4
	PAP 0305 ... P10/... P14/... P147*	0.33	3	4.5	5
	PAP 0306 ... P10/... P14/... P147*	0.4	3	4.5	6
4	PAP 0403 ... P10/... P14/... P147*	0.25	4	5.5	3
	PAP 0404 ... P10/... P14/... P147*	0.33	4	5.5	4
	PAP 0406 ... P10/... P14/... P147*	0.5	4	5.5	6
	PAP 0410 ... P10/... P14/... P147*	0.84	4	5.5	10
5	PAP 0505 ... P10/... P14/... P147*	0.72	5	7	5
	PAP 0508 ... P10/... P14/... P147*	1.1	5	7	8
	PAP 0510 ... P10/... P14/... P147*	1.4	5	7	10
6	PAP 0606 ... P10/... P14/... P147*	1	6	8	6
	PAP 0608 ... P10/... P14/... P147*	1.3	6	8	8
	PAP 0610 ... P10/... P14/... P147*	1.7	6	8	10
7	PAP 0710 ... P10/... P14/... P147*	1.9	7	9	10
8	PAP 0808 ... P10/... P14/... P147*	1.7	8	10	8
	PAP 0810 ... P10/... P14/... P147*	2.1	8	10	10
	PAP 0812 ... P10/... P14/... P147*	2.6	8	10	12
10	PAP 1008 ... P10/... P14/... P147*	2.1	10	12	8
	PAP 1010 ... P10/... P14/... P147*	2.6	10	12	10
	PAP 1012 ... P10/... P14/... P147*	3.1	10	12	12
	PAP 1015 ... P10/... P14/... P147*	3.9	10	12	15
	PAP 1020 ... P10/... P14/... P147*	5.3	10	12	20
12	PAP 1208 ... P10/... P14/... P147*	2.5	12	14	8
	PAP 1210 ... P10/... P14/... P147*	3.1	12	14	10
	PAP 1212 ... P10/... P14/... P147*	3.7	12	14	12
	PAP 1215 ... P10/... P14/... P147*	4.7	12	14	15
	PAP 1220 ... P10/... P14/... P147*	6.2	12	14	20
	PAP 1225 ... P10/... P14/... P147*	7.8	12	14	25
13	PAP 1310 ... P10/... P14/... P147*	3.3	13	15	10

* On request

9 | Models and tables of dimensions

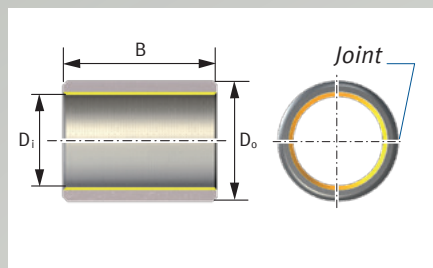

Table of dimensions - continued (dimensions in mm)

Shaft diameter	Order designation P10, P14, P147*	Earth g	Dimensions		
			Di	Do	B ±0.25
14	PAP 1410 ... P10/... P14/... P147*	3.6	14	16	10
	PAP 1412 ... P10/... P14/... P147*	4.3	14	16	12
	PAP 1415 ... P10/... P14/... P147*	5.4	14	16	15
	PAP 1420 ... P10/... P14/... P147*	7.1	14	16	20
	PAP 1425 ... P10/... P14/... P147*	9	14	16	25
15	PAP 1510 ... P10/... P14/... P147*	3.8	15	17	10
	PAP 1512 ... P10/... P14/... P147*	4.6	15	17	12
	PAP 1515 ... P10/... P14/... P147*	5.7	15	17	15
	PAP 1520 ... P10/... P14/... P147*	7.6	15	17	20
	PAP 1525 ... P10/... P14/... P147*	9.5	15	17	25
16	PAP 1610 ... P10/... P14/... P147*	4	16	18	10
	PAP 1612 ... P10/... P14/... P147*	4.9	16	18	12
	PAP 1615 ... P10/... P14/... P147*	6.1	16	18	15
	PAP 1620 ... P10/... P14/... P147*	8.1	16	18	20
	PAP 1625 ... P10/... P14/... P147*	10.1	16	18	25
18	PAP 1810 ... P10/... P14*/... P147*	4.5	18	20	10
	PAP 1815 ... P10/... P14/... P147*	6.8	18	20	15
	PAP 1820 ... P10/... P14/... P147*	9.1	18	20	20
	PAP 1825 ... P10/... P14/... P147*	11.3	18	20	25
20	PAP 2010 ... P10/... P14/... P147*	7.8	20	23	10
	PAP 2015 ... P10/... P14/... P147*	11.7	20	23	15
	PAP 2020 ... P10/... P14/... P147*	15.6	20	23	20
	PAP 2025 ... P10/... P14/... P147*	19.5	20	23	25
	PAP 2030 ... P10/... P14/... P147*	23.4	20	23	30
22	PAP 2215 ... P10/... P14/... P147*	12.7	22	25	15
	PAP 2220 ... P10/... P14/... P147*	17	22	25	20
	PAP 2225 ... P10/... P14/... P147*	21.3	22	25	25
	PAP 2230 ... P10/... P14/... P147*	25.5	22	25	30
24	PAP 2415 ... P10/... P14/... P147*	13.8	24	27	15
	PAP 2420 ... P10/... P14/... P147*	18.5	24	27	20
	PAP 2425 ... P10/... P14/... P147*	23.1	24	27	25
	PAP 2430 ... P10/... P14*/... P147*	27.7	24	27	30
25	PAP 2510 ... P10/... P14/... P147*	9.6	25	28	10
	PAP 2515 ... P10/... P14/... P147*	14.4	25	28	15
	PAP 2520 ... P10/... P14/... P147*	19.2	25	28	20
	PAP 2525 ... P10/... P14/... P147*	24	25	28	25
	PAP 2530 ... P10/... P14/... P147*	28.8	25	28	30
	PAP 2540 ... P10/... P14*/... P147*	38.4	25	28	40
28	PAP 2550 ... P10/... P14/... P147*	48	25	28	50
	PAP 2820 ... P10/... P14/... P147*	29.1	28	32	20
	PAP 2830 ... P10/... P14/... P147*	43.7	28	32	30

* On request

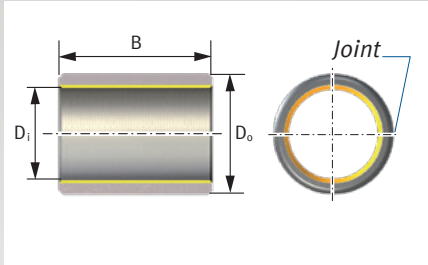

Table of dimensions - continued (dimensions in mm)					
Shaft diameter	Order designation P10, P14, P147*	Earth g	Dimensions		
			Di	Do	B ±0.25
30	PAP 3015 ... P10/... P14/... P147*	23.3	30	34	15
	PAP 3020 ... P10/... P14/... P147*	31.1	30	34	20
	PAP 3025 ... P10/... P14/... P147*	38.8	30	34	25
	PAP 3030 ... P10/... P14/... P147*	46.6	30	34	30
	PAP 3040 ... P10/... P14/... P147*	62.1	30	34	40
32	PAP 3230 ... P10/... P14/... P147*	49.5	32	36	30
	PAP 3240 ... P10/... P14/... P147*	66	32	36	40
35	PAP 3520 ... P10/... P14/... P147*	35.9	35	39	20
	PAP 3530 ... P10/... P14/... P147*	53.9	35	39	30
	PAP 3540 ... P10/... P14/... P147*	71.8	35	39	40
	PAP 3550 ... P10/... P14/... P147*	89.8	35	39	50
40	PAP 4020 ... P10/... P14/... P147*	40.8	40	44	20
	PAP 4030 ... P10/... P14/... P147*	61.2	40	44	30
	PAP 4040 ... P10/... P14/... P147*	81.5	40	44	40
	PAP 4050 ... P10/... P14/... P147*	102	40	44	50
45	PAP 4530 ... P10/... P14/... P147*	87	45	50	30
	PAP 4540 ... P10/... P14/... P147*	116	45	50	40
	PAP 4550 ... P10/... P14/... P147*	145	45	50	50
50	PAP 5020 ... P10/... P14/... P147*	64	50	55	20
	PAP 5030 ... P10/... P14/... P147*	96	50	55	30
	PAP 5040 ... P10/... P14/... P147*	128	50	55	40
	PAP 5060 ... P10/... P14/... P147*	192	50	55	60
55	PAP 5540 ... P10/... P14/... P147*	140	55	60	40
	PAP 5560 ... P10/... P14/... P147*	210	55	60	60
60	PAP 6030 ... P10/... P14/... P147*	114	60	65	30
	PAP 6040 ... P10/... P14/... P147*	152	60	65	40
	PAP 6060 ... P10/... P14/... P147*	228	60	65	60
	PAP 6070 ... P10/... P14/... P147*	266	60	65	70
65	PAP 6530 ... P10/... P14/... P147*	123	65	70	30
	PAP 6540 ... P10/... P14/... P147*	164	65	70	40
	PAP 6550 ... P10/... P14/... P147*	205	65	70	50
	PAP 6560 ... P10/... P14/... P147*	246	65	70	60
	PAP 6570 ... P10/... P14/... P147*	288	65	70	70
70	PAP 7040 ... P10/... P14/... P147*	176	70	75	40
	PAP 7050 ... P10/... P14/... P147*	221	70	75	50
	PAP 7070 ... P10/... P14/... P147*	309	70	75	70
75	PAP 7540 ... P10/... P14*/... P147*	189	75	80	40
	PAP 7550 ... P10/... P14/... P147*	236	75	80	50
	PAP 7560 ... P10/... P14/... P147*	283	75	80	60
	PAP 7580 ... P10/... P14*/... P147*	377	75	80	80

* On request

9 | Models and tables of dimensions

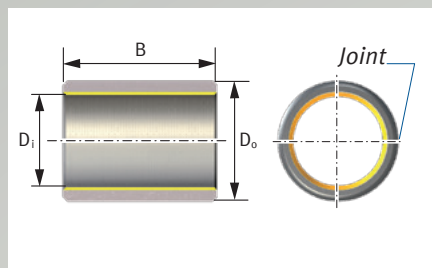

Table of dimensions · continued (dimensions in mm)					
Shaft diameter	Order designation P10, P14, P147*	Earth g	Dimensions		
			Di	Do	B ±0.25
80	PAP 8040 ... P10/... P14/... P147*	201	80	85	40
	PAP 8060 ... P10/... P14/... P147*	301	80	85	60
	PAP 8080 ... P10/... P14/... P147*	402	80	85	80
	PAP 80100 ... P10/... P14*/... P147*	502	80	85	100
85	PAP 8560 ... P10/... P14/... P147*	319	85	90	60
	PAP 85100 ... P10/... P14*/... P147*	532	85	90	100
90	PAP 9050 ... P10/... P14*/... P147*	281	90	95	50
	PAP 9060 ... P10/... P14/... P147*	338	90	95	60
	PAP 90100 ... P10/... P14/... P147*	563	90	95	100
95	PAP 9560 ... P10/... P14*/... P147*	356	95	100	60
	PAP 95100 ... P10/... P14*/... P147*	593	95	100	100
100	PAP 10050 ... P10/... P14/... P147*	312	100	105	50
	PAP 10060 ... P10/... P14/... P147*	374	100	105	60
	PAP 100115 ... P10/... P14/... P147*	717	100	105	115
105	PAP 10560 ... P10/... P14*/... P147*	392	105	110	60
	PAP 105115 ... P10/... P14*/... P147*	752	105	110	115
110	PAP 11060 ... P10/... P14/... P147*	411	110	115	60
	PAP 110115 ... P10/... P14/... P147*	787	110	115	115
115	PAP 11550 ... P10/... P14*/... P147*	357	115	120	50
	PAP 11560 ... P10/... P14*/... P147*	429	115	120	60
	PAP 11570 ... P10/... P14*/... P147*	500	115	120	70
120	PAP 12060 ... P10/... P14/... P147*	447	120	125	60
	PAP 120100 ... P10/... P14*/... P147*	745	120	125	100
125	PAP 125100 ... P10/... P14/... P147*	776	125	130	100
	PAP 13060 ... P10/... P14*/... P147*	484	130	135	60
130	PAP 130100 ... P10/... P14/... P147*	806	130	135	100
	PAP 13560 ... P10/... P14*/... P147*	502	135	140	60
135	PAP 13580 ... P10/... P14*/... P147*	669	135	140	80
	PAP 14060 ... P10/... P14/... P147*	520	140	145	60
140	PAP 140100 ... P10/... P14/... P147*	867	140	145	100
	PAP 15060 ... P10/... P14*/... P147*	557	150	155	60
150	PAP 15080 ... P10/... P14/... P147*	742	150	155	80
	PAP 150100 ... P10/... P14/... P147*	928	150	155	100
160	PAP 16080 ... P10/... P14/... P147*	791	160	165	80
	PAP 160100 ... P10/... P14*/... P147*	989	160	165	100
180	PAP 180100 ... P10/... P14/... P147*	1110	180	185	100
200	PAP 200100 ... P10/... P14/... P147*	1232	200	205	100
220	PAP 220100 ... P10/... P14*/... P147*	1354	220	225	100
250	PAP 250100 ... P10/... P14*/... P147*	1536	250	255	100
300	PAP 300100 ... P10/... P14/... P147*	1840	300	305	100

* On request

9.1.2 Model range P11 with bronze back

Recommended fitting tolerance:

Shaft		Housing bore
$5 \leq d_w < 80$	f7	H7
$80 \leq d_w$	h8	

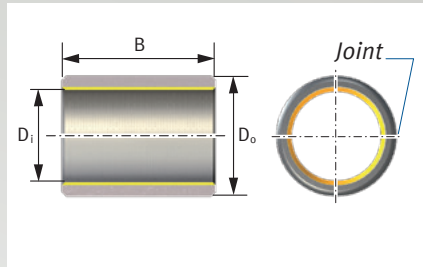

For bearing clearances, wall thicknesses and chamfer tolerances, see section 7, "Design and layout of bearing position", "Theoretical bearing clearance".

Bushes in special dimensions available on request (section 9.8).

Table of dimensions (dimensions in mm)					
Shaft diameter	Order designation P11	Earth g	Dimensions		
			Di	Do	B ±0.25
4	PAP 0406 P11	0.8	4	6	6
5	PAP 0505 P11	0.8	5	7	5
6	PAP 0606 P11	1.1	6	8	6
	PAP 0610 P11	1.8	6	8	10
8	PAP 0808 P11	1.9	8	10	8
	PAP 0810 P11	2.3	8	10	10
	PAP 0812 P11	2.8	8	10	12
10	PAP 1005 P11	1.4	10	12	5
	PAP 1010 P11	2.8	10	12	10
	PAP 1015 P11	4.2	10	12	15
	PAP 1020 P11	5.7	10	12	20
12	PAP 1210 P11	3.3	12	14	10
	PAP 1212 P11	4	12	14	12
	PAP 1215 P11	5.1	12	14	15
	PAP 1220 P11	6.7	12	14	20
	PAP 1225 P11	8.4	12	14	25
14	PAP 1415 P11	5.8	14	16	15
15	PAP 1515 P11	6.2	15	17	15
	PAP 1525 P11	10.3	15	17	25
16	PAP 1615 P11	6.6	16	18	15
	PAP 1625 P11	11	16	18	25
18	PAP 1815 P11	7.4	18	20	15
	PAP 1825 P11	12.3	18	20	25
20	PAP 2015 P11	12.8	20	23	15
	PAP 2020 P11	17	20	23	20
	PAP 2025 P11	21.3	20	23	25
	PAP 2030 P11	25.5	20	23	30
22	PAP 2215 P11	14	22	25	15
	PAP 2220 P11	18.6	22	25	20
	PAP 2225 P11	23.3	22	25	25
24	PAP2430 P11	30.3	24	27	30
25	PAP 2525 P11	26.2	25	28	25
	PAP 2530 P11	31.5	25	28	30
28	PAP 2830 P11	47.9	28	32	30

9 | Models and tables of dimensions

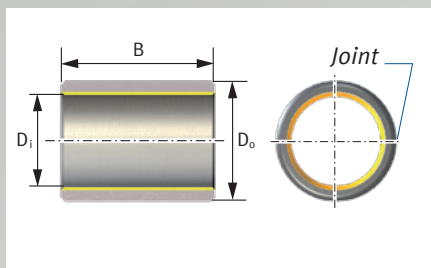
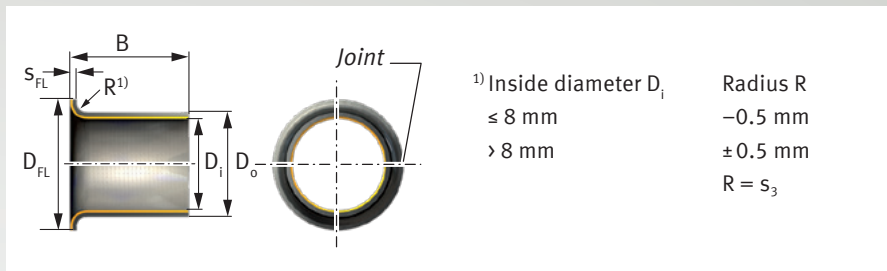

Table of dimensions · continued (dimensions in mm)					
Shaft diameter	Order designation P11	Earth g	Dimensions		
			Di	Do	B ±0.25
30	PAP 3020 P11	34.1	30	34	20
	PAP 3030 P11	51.1	30	34	30
	PAP 3040 P11	68.2	30	34	40
35	PAP 3520 P11	39.4	35	39	20
	PAP 3530 P11	59.1	35	39	30
40	PAP 4050 P11	112	40	44	50
45	PAP 4550 P11	159	45	50	50
50	PAP 5030 P11	105	50	55	30
	PAP 5040 P11	140	50	55	40
	PAP 5060 P11	211	50	55	60
55	PAP 5540 P11	154	55	60	40
60	PAP 6040 P11	167	60	65	40
	PAP 6050 P11	209	60	65	50
	PAP 6060 P11	251	60	65	60
	PAP 6070 P11	293	60	65	70
70	PAP 7050 P11	242	70	75	50
	PAP 7070 P11	339	70	75	70
80	PAP 8060 P11	331	80	85	60
	PAP 80100 P11	552	80	85	100
90	PAP 9060 P11	371	90	95	60
	PAP 90100 P11	619	90	95	100
100	PAP 10060 P11	411	100	105	60
	PAP 100115 P11	788	100	105	115

9.2 KS PERMAGLIDE® flange liners, maintenance-free

9.2.1 Model range P10, P14, P147* with steel back



Flange bushes in special dimensions available on request (section 9.8).

Table of dimensions (dimensions in mm)							
Shaft diameter	Order designation P10, P14, P147*	Earth g	Dimensions				
			D_i	D_o	$D_{FL} \pm 0.5$	$B \pm 0.25$	$s_{FL} - 0.2$
6	PAF 06040 ... P10/... P14/... P147*	0.9	6	8	12	4	1
	PAF 06070 ... P10/... P14/... P147*	1.4	6	8	12	7	1
	PAF 06080 ... P10/... P14/... P147*	1.6	6	8	12	8	1
8	PAF 08055 ... P10/... P14/... P147*	1.7	8	10	15	5.5	1
	PAF 08075 ... P10/... P14/... P147*	2.1	8	10	15	7.5	1
	PAF 08095 ... P10/... P14/... P147*	2.5	8	10	15	9.5	1
10	PAF 10070 ... P10/... P14/... P147*	2.5	10	12	18	7	1
	PAF 10090 ... P10/... P14/... P147*	3	10	12	18	9	1
	PAF 10120 ... P10/... P14/... P147*	3.8	10	12	18	12	1
	PAF 10170 ... P10/... P14/... P147*	5	10	12	18	17	1
12	PAF 12070 ... P10/... P14*/... P147*	3	12	14	20	7	1
	PAF 12090 ... P10/... P14*/... P147*	3.6	12	14	20	9	1
	PAF 12120 ... P10/... P14/... P147*	4.5	12	14	20	12	1
	PAF 12170 ... P10/... P14/... P147*	5.9	12	14	20	17	1
14	PAF 14120 ... P10/... P14/... P147*	5.1	14	16	22	12	1
	PAF 14170 ... P10/... P14/... P147*	6.9	14	16	22	17	1
15	PAF 15090 ... P10/... P14/... P147*	4.4	15	17	23	9	1
	PAF 15120 ... P10/... P14/... P147*	5.5	15	17	23	12	1
	PAF 15170 ... P10/... P14/... P147*	7.3	15	17	23	17	1
16	PAF 16120 ... P10/... P14/... P147*	5.8	16	18	24	12	1
	PAF 16170 ... P10/... P14/... P147*	7.8	16	18	24	17	1
18	PAF 18120 ... P10/... P14/... P147*	6.5	18	20	26	12	1
	PAF 18170 ... P10/... P14/... P147*	8.7	18	20	26	17	1
	PAF 18220 ... P10/... P14/... P147*	10.9	18	20	26	22	1
20	PAF 20115 ... P10/... P14/... P147*	11.4	20	23	30	11.5	1.5
	PAF 20165 ... P10/... P14/... P147*	15.1	20	23	30	16.5	1.5
	PAF 20215 ... P10/... P14/... P147*	18.9	20	23	30	21.5	1.5
25	PAF 25115 ... P10/... P14/... P147*	14	25	28	35	11.5	1.5
	PAF 25165 ... P10/... P14/... P147*	18.6	25	28	35	16.5	1.5
	PAF 25215 ... P10/... P14/... P147*	23.5	25	28	35	21.5	1.5
30	PAF 30160 ... P10/... P14/... P147*	30.5	30	34	42	16	2
	PAF 30260 ... P10/... P14/... P147*	45.5	30	34	42	26	2
35	PAF 35160 ... P10/... P14/... P147*	35	35	39	47	16	2
	PAF 35260 ... P10/... P14/... P147*	53	35	39	47	26	2
40	PAF 40260 ... P10/... P14/... P147*	61	40	44	53	26	2

* On request

9 | Models and tables of dimensions

9.2.2 Model range P11 with bronze back

Recommended fitting tolerance:

Shaft	Housing bore
f7	H7

For bearing clearances, wall thicknesses and chamfer tolerances, see section 7, "Design and layout of bearing position", "Theoretical bearing clearance".

Flange bushes in special dimensions available on request (section 9.8).

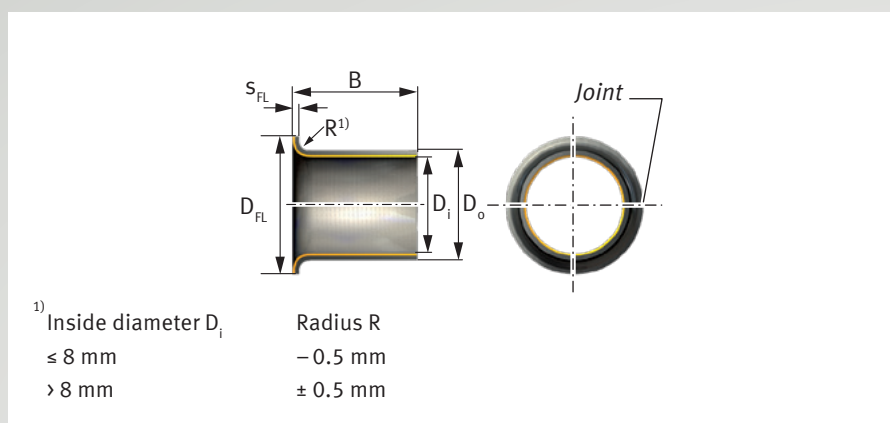

Table of dimensions (dimensions in mm)							
Shaft diameter	Order designation P11	Earth ξ	Dimensions				
			D_i	D_o	$D_{FL} \pm 0.5$	$B \pm 0.25$	$S_{FL} - 0.2$
6	PAF 06080 P11	1.8	6	8	12	8	1
8	PAF 08055 P11	1.8	8	10	15	5.5	1
	PAF 08095 P11	2.7	8	10	15	9.5	1
10	PAF 10070 P11	2.7	10	12	18	7	1
	PAF 10120 P11	4.1	10	12	18	12	1
	PAF 10170 P11	5.5	10	12	18	17	1
12	PAF 12070 P11	3.2	12	14	20	7	1
	PAF 12090 P11	3.9	12	14	20	9	1
	PAF 12120 P11	4.9	12	14	20	12	1
15	PAF 15120 P11	6	15	17	23	12	1
	PAF 15170 P11	8	15	17	23	17	1
16	PAF 16120 P11	6.3	16	18	24	12	1
18	PAF 18100 P11	6.1	18	20	26	10	1
	PAF 18220 P11	11.8	18	20	26	22	1
20	PAF 20115 P11	12.4	20	23	30	11.5	1.5
	PAF 20165 P11	16.6	20	23	30	16.5	1.5
25	PAF 25215 P11	25.5	25	28	35	21.5	1.5
30	PAF 30160 P11	33.5	30	34	42	16	2
	PAF 30260 P11	50	30	34	42	26	2
35	PAF 35260 P11	58	35	39	47	26	2
40	PAF 40260 P11	67	40	44	53	26	2

9.3 KS PERMAGLIDE® thrust washers, maintenance-free

9.3.1 Model range P10, P14, P147* with steel back and model range P11 with bronze back

Thrust washers in special dimensions available on request (section 9.8).

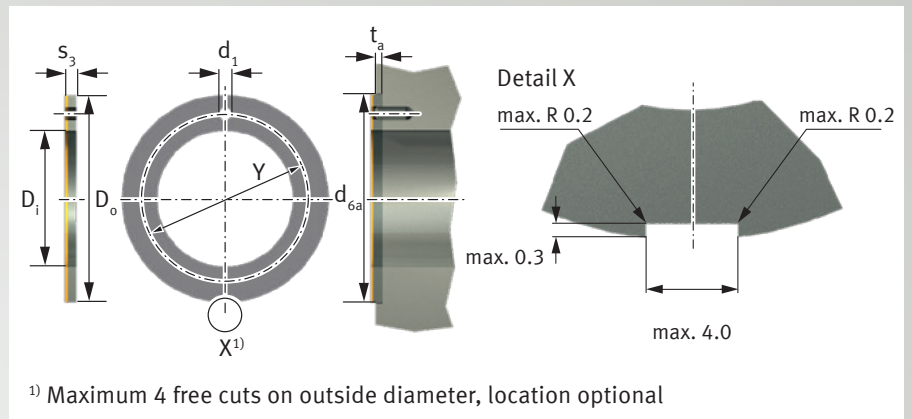

Table of dimensions (dimensions in mm)									
Order designation P10, P11, P14, P147*	Earth g	Dimensions					Connection dimensions		
		$D_i +0.25$	$D_o -0.25$	$s_3 -0.05$	$J \pm 0.12$	$d_1 +0.4 +0.1$	$t_a \pm 0.2$	$d_{6a} +0.12$	
PAW 10 ... P10/... P11/... P14/... P147*	2.7	10	20	1.5	15	1.5	1	20	
PAW 12 ... P10/... P11/... P14/... P147*	3.9	12	24	1.5	18	1.5	1	24	
PAW 14 ... P10/... P11*/... P14/... P147*	4.3	14	26	1.5	20	2	1	26	
PAW 16 ... P10/... P11/... P14/... P147*	5.8	16	30	1.5	22	2	1	30	
PAW 18 ... P10/... P11/... P14/... P147*	6.3	18	32	1.5	25	2	1	32	
PAW 20 ... P10/... P11/... P14/... P147*	8.1	20	36	1.5	28	3	1	36	
PAW 22 ... P10/... P11/... P14/... P147*	8.7	22	38	1.5	30	3	1	38	
PAW 26 ... P10/... P11/... P14/... P147*	11.4	26	44	1.5	35	3	1	44	
PAW 28 ... P10/... P11/... P14/... P147*	13.7	28	48	1.5	38	4	1	48	
PAW 32 ... P10/... P11/... P14/... P147*	17.1	32	54	1.5	43	4	1	54	
PAW 38 ... P10/... P11/... P14/... P147*	21.5	38	62	1.5	50	4	1	62	
PAW 42 ... P10/... P11/... P14/... P147*	23.5	42	66	1.5	54	4	1	66	
PAW 48 ... P10/... P11/... P14/... P147*	38.5	48	74	2	61	4	1.5	74	
PAW 52 ... P10/... P11/... P14/... P147*	41	52	78	2	65	4	1.5	78	
PAW 62 ... P10/... P11/... P14/... P147*	52	62	90	2	76	4	1.5	90	

* On request

9 | Models and tables of dimensions

9.4 KS PERMAGLIDE® strips, maintenance-free

9.4.1 Model range P10, P14, P147* with steel back – model range P11 with bronze back

Strips in special dimensions available on request (section 9.8).

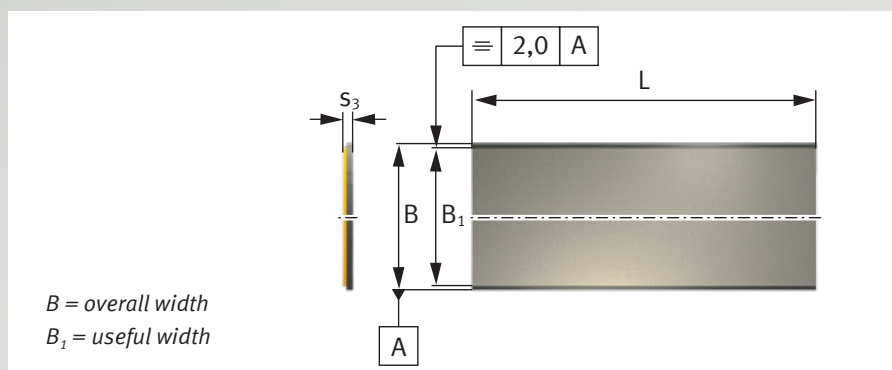

Table of dimensions (dimensions in mm)					
Order designation P10, P14, P147	Earth g	Dimensions			
		s_3 -0.04	B +1.5	B_1	L +3
PAS 05180 ... P10/... P14/... P147*	330	0.5	180	168	500
PAS 07250 ... P10/... P14/... P147*	703	0.75	250	238	500
PAS 10250 ... P10/... P14/... P147*	948	1	250	238	500
PAS 15250 ... P10/... P14/... P147*	1439	1.5	250	238	500
PAS 20250 ... P10/... P14/... P147*	1930	2	250	238	500
PAS 25250 ... P10/... P14/... P147*	2420	2.5	250	238	500
PAS 30250 ... P10/... P14/... P147*	2970	3.06	250	238	500

Table of dimensions (dimensions in mm)					
Order designation P11	Earth g	Dimensions			
		s_3 -0.04	B +1.5	B_1	L +3
PAS 10160 P11	658	1	160	148	500
PAS 15180 P11	1132	1.5	180	168	500
PAS 20180 P11	1523	2	180	168	500
PAS 25180 P11	1915	2.5	180	168	500

* On request

9.5 KS PERMAGLIDE® bushes, low-maintenance

9.5.1 Model range P20, P200

Recommended fitting tolerance:

Shaft	Housing bore
h8	H7

Shaping the lubricating bore by roll bending is permitted.

For bearing clearances, wall thicknesses and chamfer tolerances, see section 7, "Design and layout of bearing position", "Theoretical bearing clearance".

Bushes P22, P23, P202 and P203 available on request. Bushes in special dimensions available on request (section 9.8).

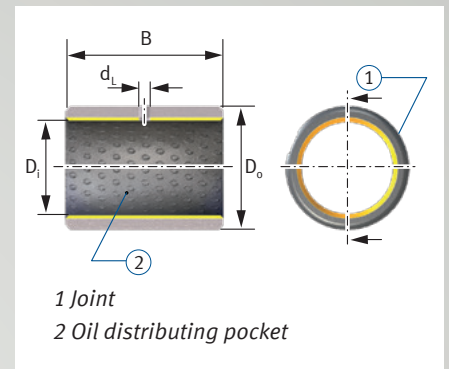

Table of dimensions (dimensions in mm)						
Shaft diameter	Order designation P20, P200*	Earth g	Dimensions			
			D _i	D _o	B ±0.25	d _L
8	PAP 0808 ... P20/... P200*	1.6	8	10	8	– ¹⁾
	PAP 0810 ... P20/... P200*	2	8	10	10	– ¹⁾
	PAP 0812 ... P20/... P200*	2.4	8	10	12	– ¹⁾
10	PAP 1008 ... P20/... P200*	2	10	12	8	– ¹⁾
	PAP 1010 ... P20/... P200*	2.4	10	12	10	3
	PAP 1015 ... P20/... P200*	3.7	10	12	15	3
12	PAP 1210 ... P20/... P200*	2.9	12	14	10	3
	PAP 1212 ... P20/... P200*	3.5	12	14	12	3
	PAP 1215 ... P20/... P200*	4.4	12	14	15	3
	PAP 1220 ... P20/... P200*	5.9	12	14	20	3
14	PAP 1420 ... P20/... P200*	6.8	14	16	20	3
15	PAP 1510 ... P20/... P200*	3.6	15	17	10	3
	PAP 1515 ... P20/... P200*	5.4	15	17	15	3
	PAP 1525 ... P20/... P200*	9	15	17	25	3
16	PAP 1612 ... P20/... P200*	4.6	16	18	12	3
	PAP 1615 ... P20/... P200*	5.7	16	18	15	3
	PAP 1620 ... P20/... P200*	7.7	16	18	20	3
18	PAP 1815 ... P20/... P200*	6.4	18	20	15	3
	PAP 1820 ... P20/... P200*	8.6	18	20	20	3
20	PAP 2015 ... P20/... P200*	11.2	20	23	15	3
	PAP 2020 ... P20/... P200*	15	20	23	20	3
	PAP 2025 ... P20/... P200*	18.8	20	23	25	3
	PAP 2030 ... P20/... P200	23.1	20	23	30	3
22	PAP 2220 ... P20/... P200*	16.4	22	25	20	3

¹⁾ No oil hole
* On request

9 | Models and tables of dimensions

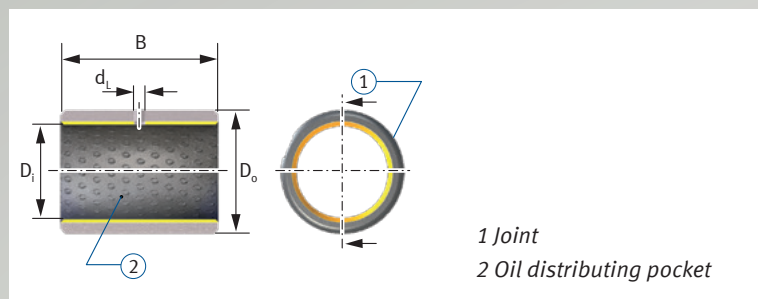

Table of dimensions - continued (dimensions in mm)						
Shaft diameter	Order designation P20, P200*	Earth g	Dimensions			
			Di	Do	B ±0.25	di
25	PAP 2515 ... P20/... P200*	13.9	25	28	15	4
	PAP 2520 ... P20/... P200*	18.5	25	28	20	4
	PAP 2525 ... P20/... P200*	23.1	25	28	25	4
	PAP 2530 ... P20/... P200*	27.8	25	28	30	4
28	PAP 2830 ... P20/... P200*	42.6	28	32	30	4
30	PAP 3020 ... P20/... P200*	30.3	30	34	20	4
	PAP 3025 ... P20/... P200*	37.8	30	34	25	4
	PAP 3030 ... P20/... P200*	45.4	30	34	30	4
	PAP 3040 ... P20/... P200*	60.6	30	34	40	4
32	PAP 3230 ... P20/... P200*	48.2	32	36	30	4
35	PAP 3520 ... P20/... P200*	35	35	39	20	4
	PAP 3530 ... P20/... P200*	52.5	35	39	30	4
	PAP 3550 ... P20/... P200*	87.5	35	39	50	4
40	PAP 4020 ... P20/... P200*	39.7	40	44	20	4
	PAP 4030 ... P20/... P200*	59.6	40	44	30	4
	PAP 4040 ... P20/... P200*	79.5	40	44	40	4
	PAP 4050 ... P20/... P200*	99.3	40	44	50	4
45	PAP 4540 ... P20/... P200*	113	45	50	40	5
	PAP 4550 ... P20/... P200*	142	45	50	50	5
50	PAP 5025 ... P20/... P200*	78	50	55	25	5
	PAP 5040 ... P20/... P200*	125	50	55	40	5
	PAP 5060 ... P20/... P200*	188	50	55	60	5
55	PAP 5540 ... P20/... P200*	137	55	60	40	5
60	PAP 6030 ... P20/... P200*	112	60	65	30	6
	PAP 6040 ... P20/... P200*	142	60	65	40	6
	PAP 6060 ... P20/... P200	224	60	65	60	6
	PAP 6070 ... P20/... P200*	254	60	65	70	6
70	PAP 7040 ... P20/... P200*	173	70	75	40	6
	PAP 7050 ... P20/... P200*	216	70	75	50	6
	PAP 7070 ... P20/... P200*	303	70	75	70	6
75	PAP 7540 ... P20/... P200*	185	75	80	40	6
	PAP 7580 ... P20/... P200*	370	75	80	80	6
80	PAP 8040 ... P20/... P200*	197	80	85	40	6
	PAP 8055 ... P20/... P200*	271	80	85	55	6
	PAP 8060 ... P20/... P200*	295	80	85	60	6
	PAP 8080 ... P20/... P200*	394	80	85	80	6
90	PAP 9060 ... P20/... P200*	331	90	95	60	6
100	PAP 10050 ... P20/... P200*	305	100	105	50	8
	PAP 10060 ... P20/... P200*	366	100	105	60	8

* On request

9.6 KS PERMAGLIDE® thrust washers, low-maintenance

9.6.1 Model range P20, P200

Thrust washers of P22, P23, P202 and P203 available on request.

Thrust washers in special dimensions available on request (see section 9.8).

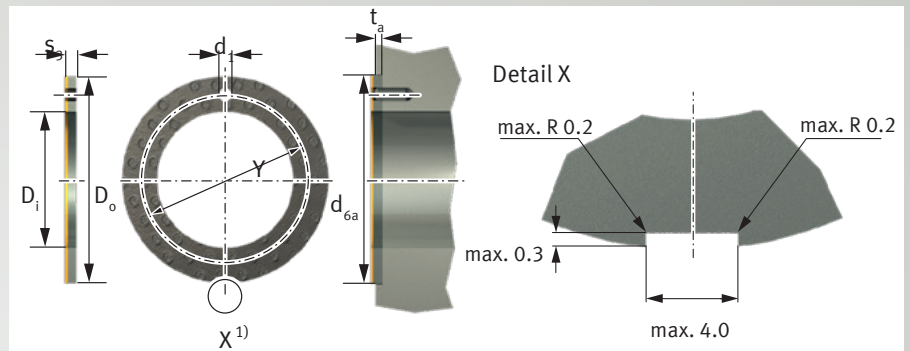

Table of dimensions (dimensions in mm)									
Order designation P20, P200*	Earth g	Dimensions					Connection dimensions		
		D_i +0.25	D_o -0.25	s_3 -0.05	Y ±0.12	d_1 +0.4 +0.1	t_a ±0.2	d_{6a} +0.12	
PAW 12 ... P20/... P200*	3.8	12	24	1.5	18	1.5	1	24	
PAW 14 ... P20/... P200*	4.2	14	26	1.5	20	2	1	26	
PAW 18 ... P20/... P200*	6.1	18	32	1.5	25	2	1	32	
PAW 20 ... P20/... P200*	7.8	20	36	1.5	28	3	1	36	
PAW 22 ... P20/... P200*	8.4	22	38	1.5	30	3	1	38	
PAW 26 ... P20/... P200*	11	26	44	1.5	35	3	1	44	
PAW 28 ... P20/... P200*	13.3	28	48	1.5	38	4	1	48	
PAW 32 ... P20/... P200*	16.5	32	54	1.5	43	4	1	54	
PAW 38 ... P20/... P200*	21	38	62	1.5	50	4	1	62	
PAW 42 ... P20/... P200*	22.5	42	66	1.5	54	4	1	66	
PAW 48 ... P20/... P200*	37.5	48	74	2	61	4	1.5	74	
PAW 52 ... P20/... P200*	40	52	78	2	65	4	1.5	78	

¹⁾ Maximum 4 free cuts on outside diameter, location optional

* On request

9 | Models and tables of dimensions

9.7 KS PERMAGLIDE® strips, low-maintenance

9.7.1 Model range P20, P200

- P20 With oil distributing pocket, ready to install
- P22 Without oil distributing pocket, with machining allowance ¹⁾
- P23 Without oil distributing pocket, ready to install
- P200 With oil distributing pocket, ready to install
- P202 Without oil distributing pocket, with machining allowance ¹⁾
- P203 Without oil distributing pocket, ready to install

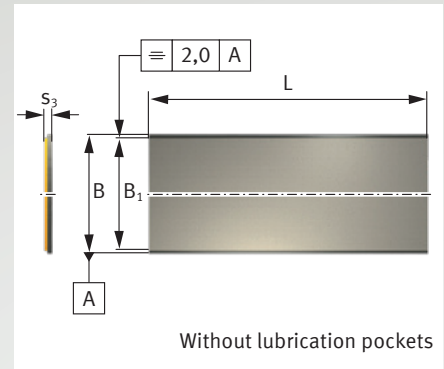
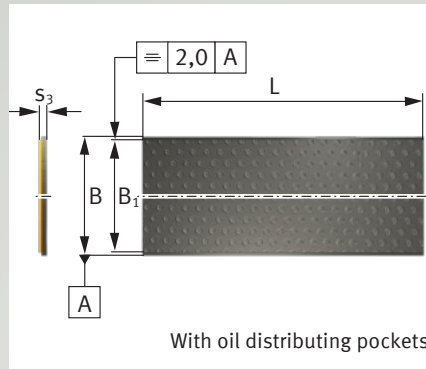

B = overall width
 B_1 = useful width

Strips P22, P23, P200, P202 and P203 available on request.

Strips in special dimensions available on request (section 9.8).

Table of dimensions (dimensions in mm)						
Order designation P20, P200, P23, P203	Earth g	Dimensions				
		s_3 -0.04	B +1.5	B_1	L +3	
PAS 10180 ... P20/... P200/... P23/... P203	640	0.99	180	168	500	
PAS 15180 ... P20/... P200/... P23/... P203	986	1.48	180	168	500	
PAS 20180 ... P20/... P200/... P23/... P203	1332	1.97	180	168	500	
PAS 25180 ... P20/... P200/... P23/... P203	1678	2.46	180	168	500	

Table of dimensions (dimensions in mm)						
Order designation P22, P202	Earth g	Dimensions				
		s_3 -0.04	B +1.5	B_1	L +3	
PAS 10180 ... P22/... P202	988	1.11	180	168	500	
PAS 15180 ... P22/... P202	1375	1.61	180	168	500	
PAS 20180 ... P22/... P202	1833	2.11	180	168	500	
PAS 25180 ... P22/... P202	2279	2.63	180	168	500	

Supplied on request.

¹⁾ Machining allowance: 0.15 mm.

9.8 KS PERMAGLIDE® plain bearings, special production according to customer specification

Motorservice manufactures KS PERMAGLIDE® plain bearings with custom widths or diameters, as well as special adaptations such as lubricating bores or internal grooves.

- Special productions are available in all standard materials: P10/P11/P14/P147, P20/P22/P23/P200/P202/P203
- Production is carried out in accordance with the highest quality standards with tolerances to meet DIN ISO 3547.

Our sales team are happy to advise you on special productions and individual solutions for your application.

Possible specifications	Special production of plain bearings	Machining
	Custom width, diameter 8 to 160 mm	Shortening by machining of a wider standard bush
	Custom diameter, any intermediate sizes from 80 to 600 mm diameter	Rolling of plain bearing plates
	Plain bearings with recesses, such as Round hole bores Oblong hole bores Lubrication bores Internal grooves etc.	Milling of standard plain bearings or special productions, production in accordance with your drawing
		

10.1 Testing wrapped bushes

Unlike a cylindrical pipe section, wrapped bushes are produced from a level section of material through shaping. They therefore feature a joint that may be open when free. The wrapped bush only has a closed joint and the required dimensional and contouring accuracy after it has been pressed into the bearing housing. Before mounting, the outside diameter D_o and inside diameter D_i of wrapped bushes can only be measured using special test methods and testing devices.

Bush outside diameter D_o

Test A, DIN ISO 3547 Part 2

Here, the wrapped bush is placed into a two-piece test holder with defined test diameter d_{ch} , with the joint facing upwards. The test holder is subjected to a test force F_{ch} . The distance z between the dies changes under the test force. The bush diameter D_o is then calculated from this measured value Δz .

Bush inside diameter D_i

Test C with gauge, DIN ISO 3547 Part 2

The wrapped bush is pressed into a gauge ring with a test diameter defined according to DIN ISO 3547 Part 1, Tab. 5. The bush inside diameter D_i is checked using a go/no go plug gauge or a 3-point touch probe.

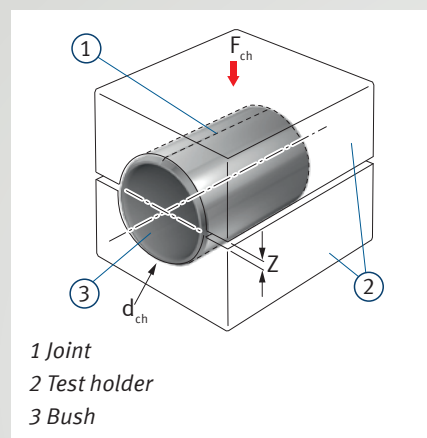

Fig. 64: Test of bush outside diameter D_o

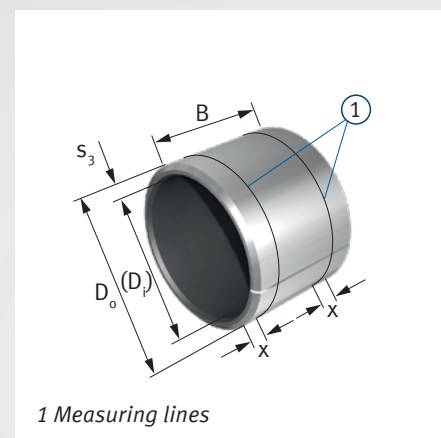

Fig. 65: Measuring lines for the wall thickness test (example)

Test D, DIN ISO 3547 Part 2

Wrapped bushes with an outside diameter $D_o > 180$ mm are tested using a precision tape measure. Here, the tape measure is placed around the centre of the bush, and sufficient tension applied to close the joint. The measured circumference Δz indicates the difference between the adjusting mandrel and the bush. From this value, the bush outside diameter D_o is calculated.

Wall thickness test of the wrapped bush (following agreement)

The wall thickness test is set out in DIN ISO 12036.

The bush wall thickness s_3 is tested on one, two or three measuring lines, depending on the liner length B .

Following agreement, the test can be performed in accordance with the aforementioned standard:



Attention:

The wall thickness s_3 and bush inside diameter must not be given simultaneously as a test dimension.

Note:

The section on the testing of wrapped bushes describes the most important processes in a generalised fashion. It is to be used purely for the purpose of information. The exact procedure is set out in the respective current standards. These standards alone must be used to determine the dimensional and functional quality of wrapped bushes.

10.2 Machining the sliding layer

The sliding layer of KS PERMAGLIDE® P22 and P202 has a machining allowance of around 0.15 mm. This can be machined by turning, drilling or reaming to:

- Achieve smaller clearance tolerances
- Compensate for misalignments

Tried and tested methods are turning and boring with:

- Dry cutting
- Cutting speeds from 100 to 150 m/min
- Feed rate of 0.05 mm/rev
- Cutting depth of max. 0.1 mm
- Carbide tools (Fig. 66)



Attention:

- Machining temperatures above 140 °C constitute a health hazard.
- P22 chips contain lead. Lead is hazardous to health.
- Changes in colour may occur on the polymer sliding layer due to high-energy radiation e.g. UV-light. To protect the surfaces, exposure to direct sunlight should be avoided.
- Removing more material reduces service life.
- Inexpert machining will have a negative impact on service life and load bearing capacity.
- Parts must be cleaned after machining.

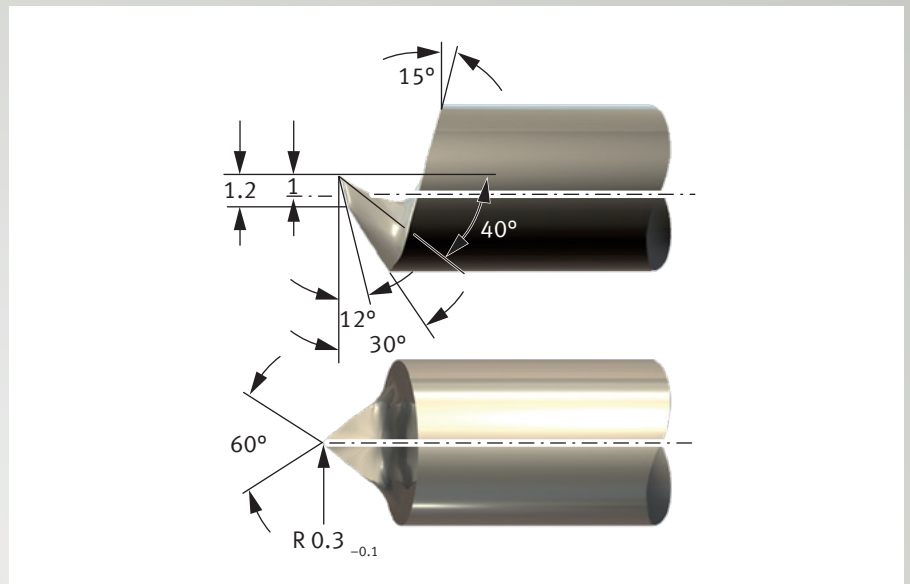

Fig. 66: Cutting tool for KS PERMAGLIDE® P22 and P202

Delivery condition, storage

Delivery condition

- Packed in a bag in a cardboard box, or
- packed in a cardboard box.

Storage

KS PERMAGLIDE® plain bearings should be stored:

- In a dry, clean place
- At a constant temperature, as far as possible
- At a relative humidity of max. 65 %.



Attention:

Keep packaging closed, where possible. KS PERMAGLIDE® plain bearings should only be removed from the original packaging immediately before installation.

Environmental issues, health & safety

In your own interests, please observe legislation and other regulations concerning

- protection of the environment
- health and safety and similar issues.

References

References

/1/ Damm, Höne, Reinicke, Skiadas:

Gleitlager im Automobil. (Plain bearings in cars)

Moderne Industrie publishing house, Volume 322, 2009

/2/ Berger:

Untersuchungen an wartungsfreien Verbundgleitlagern (Tests on maintenance-free compound plain bearings).

Shaker publishing house, Aachen, 2000

Further reading:

Broichhausen:

Schadenskunde, Analyse und Vermeidung von Schäden (Investigation, analysis and prevention of damage).

Hanser publishing house, Munich, Vienna, 1985

Stork:

Lebensdauervorhersage wartungsfreier, dynamisch belasteter Verbundgleitlager mit Hilfe neuronaler Netze (Service life prediction of maintenance-free, dynamically loaded compound plain bearings using neural networks)

Shaker publishing house, Aachen, 2003

Motorservice – Your premium supplier

Sales support and technical customer service

- Expert advice for order and delivery processing
- Online catalogue with calculation tool, CAD drawings and 3D views
- Product catalogues and product information – on request as personalised version with your address and logo
- Sales promotion: trade fair presentations, product samples, promotional items and give-aways
- Always stay up to date with our newsletter and website: www.permaglide.com
- Individual advice, calculations and plain bearing design
- Special designs according to your requirements

Our experience is your gain

- Over 30 years of expertise in the manufacture of KS PERMAGLIDE® plain bearings
- Top quality standards of the German automotive industry
- Practical test rigs according to your requirements
- Material and process development

Logistics performance

- High availability and warehouse storage
- Quick order processing and commissioning

Consistently high quality

Comprehensive technical service

High availability and warehouse storage

KS PERMAGLIDE® plain bearings –
to ensure that everything runs smoothly.





MOTORSERVICE
RHEINMETALL AUTOMOTIVE

Original KS PERMAGLIDE® plain bearings

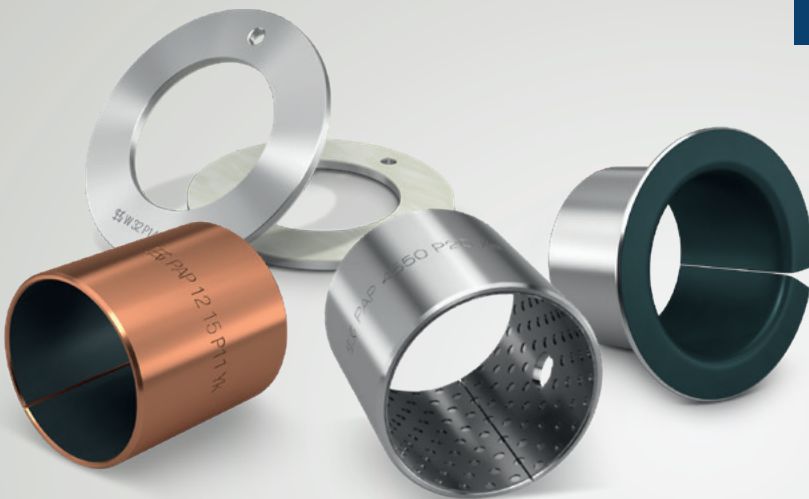

KS PERMAGLIDE® Partner:

International Sales:

MS Motorservice Deutschland GmbH

Rudolf-Diesel-Straße 9

71732 Tamm, Germany

Phone: +49 7141 8661-433

Fax: +49 7141 8661-430

www.permaglide.com

Production:

KS Gleitlager GmbH

Am Bahnhof 14

68789 St. Leon-Rot, Germany

Phone: +49 6227 56-0

Fax: +49 6227 56-302

www.rheinmetall-automotive.com



50 003 863-02 – EN – 02/16 (032018)
© MS Motorservice Deutschland GmbH – A Rheinmetall Company